

TO EXTEND CABLE:

SAFETY PRECAUTION
Always inspect the cable throughout its length for kinks, frays or damage before using your pulter.

Secure hook and pulley to a rigid anchor. Depress drive pawl spring in direction of arrow at detail "A". Raise handle and hold firmly in this position, then depress stop pawl in direction of arrow at detail "B" and at the same time pull until desired slack is obtained.

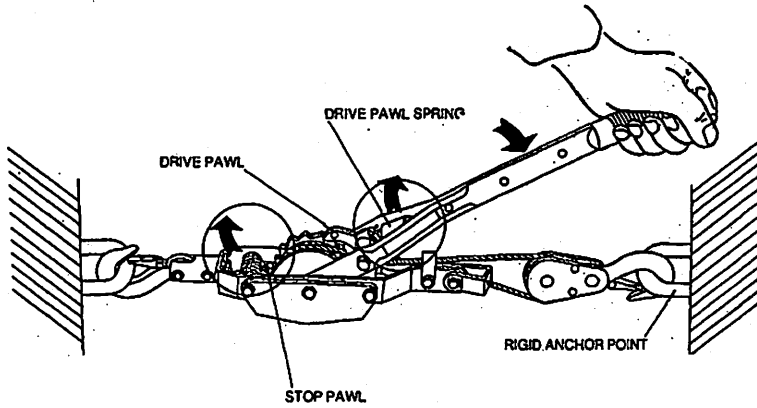

TO RAISE LOAD OR APPLY TENSION

Engage drive pawl and ratchet wheel by pushing pawl spring in direction of arrow at detail "A". Each stroke of handle will wind cable to pull load.

CAUTION:
DO NOT overload

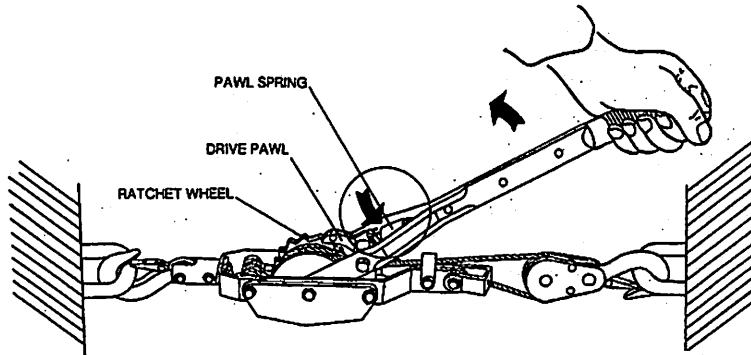

TO OR RELEASE TENSION:

Depress pawl spring in direction of arrow at detail—"A"
Steadily push handle until drive pawl pushes and disengages
stop pawl (not shown) to clear ratchet tooth. This releases
load one notch. Repeat this handle motion as required to
release tension a notch at a time.

CAUTION:

When releasing load avoid abrupt
handle movements. Apply pres-
sure to handle with an even and
steady force.

