

Essex Silver-Line SL7 Parts Diagram



Read This Book

This book has important information for the use and safe operation of this equipment. Failure to read this book prior to operating or attempting any service or maintenance procedure for your Silver-Line machine could result in injury to you or to other personnel; damage to the machine or to other property could occur as well. You must have training in the operation of this machine before using it. If you or your operator(s) cannot read English, have this manual explained fully before attempting to operate this machine.

All directions given in this book are seen from operator's position at the rear of the machine.

Essex Silver-Line Corporation, 1118 Lakeview Ave. PO Box 40, Dracut, MA 01826

www.essex-silver-line.com

(January 2011)

Refinishing The Silver-Line Way

(Visit our website www.essex-silver-line.com under consumer tips for complete information)

Job Preparation:

Remove the furniture, wall hangings, etc. Clear the room out!
Remove the old carpet, carpet pad and carpet strip (where necessary)
Locate & Reserve *only* Silver-Line Sanders & Edgers from your local rental store
Watch the Silver-Line "How to" Video

Inspect the floor for and remove...

Staples from the carpet pad

Nails from the tackstrip

Nails protruding from the floor (countersink these nails)

Make sure you are very diligent when completing this task, protect the rental machine!

You may be liable for damage to the drum and disc pad on the rental equipment!

Protect the rest of your house from sawdust, sweep the floor and vacuum, and pick up the equipment!

Sanding the Floor:

What are you trying to accomplish during this project? First, you want to level the floor, and remove the old finish. The remaining cuts or passes are to remove the scratch marks made by the previous cuts. Do not skip too many grits when sanding the floor, as the finer grits may not be able to remove the heavier scratches.

Start the process with the highest grit possible to complete the first cut, leveling and removing the finish. If a 36 or 40 grit will accomplish the task, then do not use 20 grit or heavier. If it seems to be taking too long, drop down and use the heavier grit. By doing this you will probably save time.

Break the room down into two sections, 1/3 to 2/3 and sand the larger area first. Complete the 2/3 section and turn around to sand the remaining 1/3. *Do this with all the grits.* Offset where you stop and start the sanding so you do not end up with a line across your floor at the end of the project.

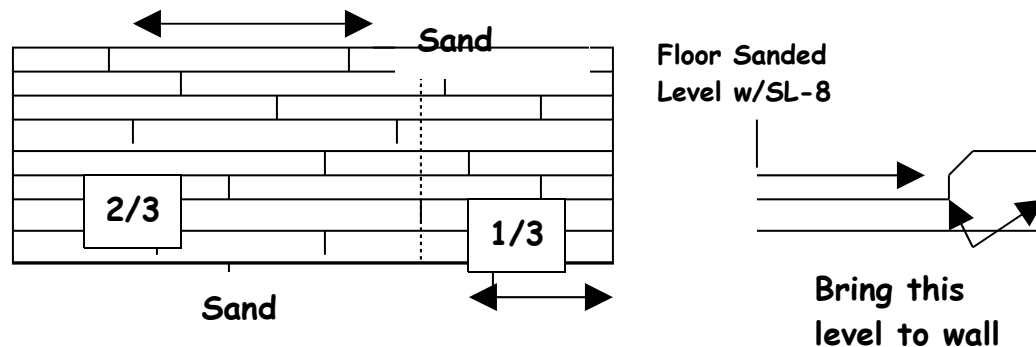

Use the SL-8 sander for the main section of the floor and then follow with the SL-7 edger. This method will allow you to set the level you want in the main section of the floor and then bring it out to the edge of the room with the SL-7.

To use the Silver-Line SL-8 correctly, you sand forward and backward on the same line with the SL-8 sander. Be sure to lift up on the handle with enough force to keep the drum pressure constant on the floor. Feather the sander so the drum comes off the floor while moving forward or backward when you reach an area that you need to stop.

The following grits are recommended for a professional looking sanding job. Again, you want to start with the least aggressive grit to complete the leveling and finish removal and proceed up through the grits.

20, 36 or 40, 60 and finally 100

Note: If you trip a breaker or blow fuse, turn off the equipment off, then reset the breaker or replace the fuse.

Note: Remove all sawdust from the house as you empty the dust bags. Empty your sander bags when they are $\frac{1}{2}$ full, this will help with the dust pick up. Sawdust can be flammable and you do not want it in your house.

Note: When using the **SL-7** edger, sand from right to left and let the edger do the work. A properly aligned edger, with a disc pad in good condition will function well without the user exerting additional pressure. Let the edger do the work; don't put extra pressure on the machine. Work at a pace you are comfortable with, and take frequent rests.

If the cutting action of you sander seems to slow or diminish, it is probably time to change the sandpaper. In an effort to save money, don't try to extend the life of the paper, replace it as needed. If you skimp on the amount of paper you use on this project it will affect the end result. Don't look at the cost at the time of sanding, but rather over the life of the floor. Replace abrasives to get the same type of cut across the floor.

After you sand the floor with the **SL-8, SL8V2 & SL-7** it is time to scrape corners, door jambs, etc. Use our 12 wood handle scraper with a 1" Red Devil blade, available from the rental store, to accomplish this task. Hand sand the areas you scraped.

If you have areas such as baseboard heat, radiators or toekicks that could not be reached by the **SL-7**, use the Silver-Line **U2** underradiator sander to clean up these areas. It uses 5" abrasive (either PSA or Hook & Loop) discs and is also available at the rental store.

When your done sanding your floor return your sanders to the rental store. Remember to return the cords, wrenches, bags and unused supplies.

Note: After sanding you should screen the floor before you apply any finish or stain to achieve the best possible finish. A professional floor sander will screen his work; spend the time and money to screen your floor.

Proper Application & Use of *Silver-Line Abrasives*

12, 16, 20* grit Sheets & Discs

For removing old surface coatings and leveling uneven floors

36, 40* grit Sheets & Discs

For intermediate sanding of floors following rough sanding.

For initial sanding of moderately worn floors

60*, 80, 100* grit Sheets & Discs

For finish sanding of all floors prior to applying new coatings

For removing light scratches, sanding marks and minor surface damage

60, 80, 100, 120, 150 & 180 grit Sandscreens

For removing fine scratch marks prior to applying new coatings

For light sanding between surface coatings

*Indicates most popular rental grits for sanding floors. 60 & 100 grit should be used in succession for proper finish. Never skip more than two grits when sanding a floor.

Example: Do not jump from 36 grit to 80 or 100 grit

Always start your sanding project with the highest possible grit that will cut and level your floor. If the grit will not cut the finish or level the floor, go down one grit size to complete the cut!

White* Thick Nylon Pads

Buffing, for polishing floors where highest luster is desired

Green Thick Nylon Pads

Scrubbing, for general duty scrubbing and spot removal on floors

Black Thick Nylon Pads

Stripping, for heavy duty wet stripping of floors

* *White pads should be used under the padlocks when using sand screens on rotary and orbital polishers. They are used for driving sandpaper on Orbital Polishers.*

Notes:

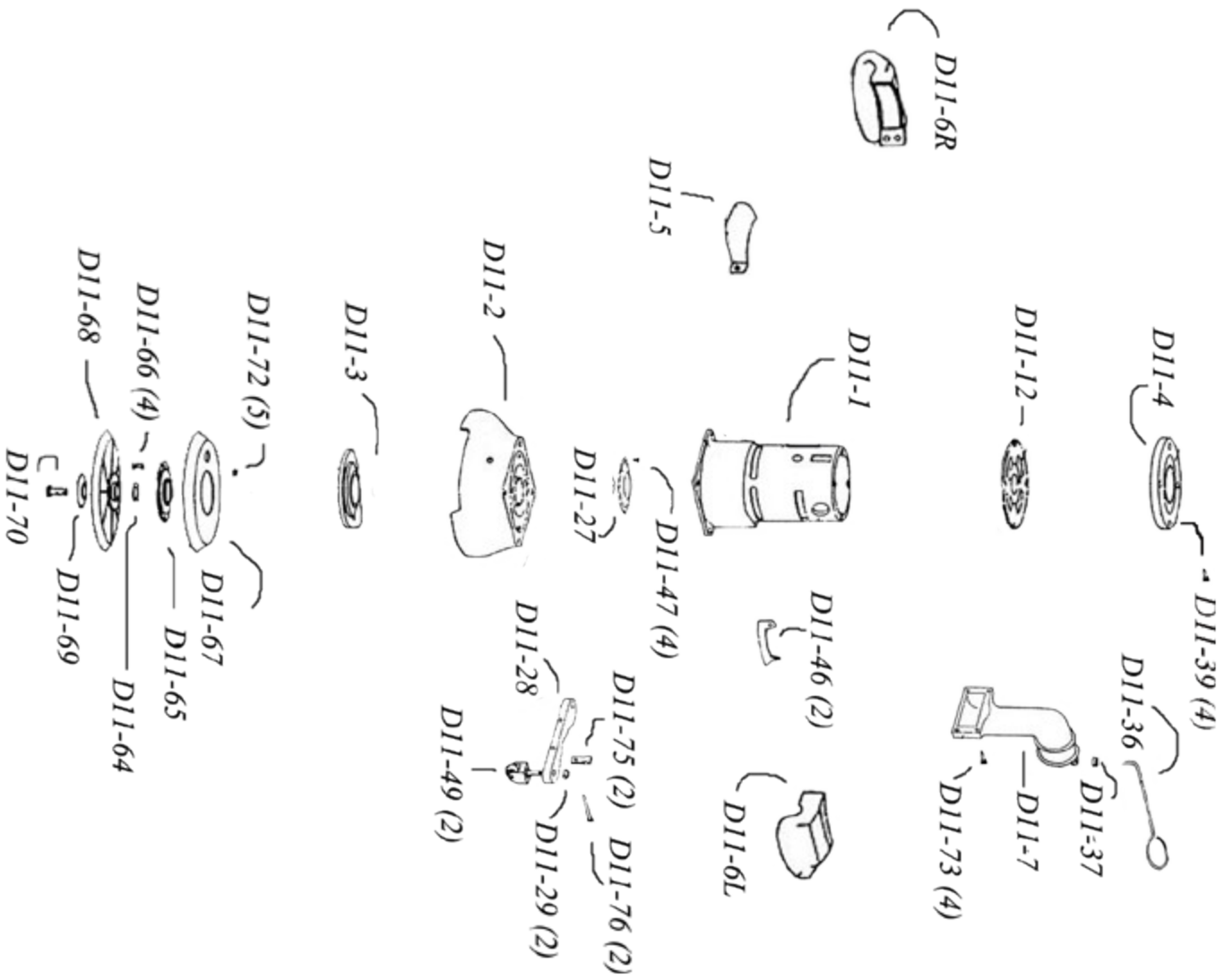

Diagram 11

Diagram	#	QTY	Item	Description	List Price	Diagram
D11	D11-1	1	C71	C7-1 Motor Frame	\$ 344.99	D11
D11	D11-12	1	C712	C7-12 Bearing plate	\$ 58.99	D11
	D11-12A	1	C712A	C7-12A Load Spring (Not Shown)	\$ 3.99	
		2	C713	C7-13 Nameplate screw (Not Shown)	\$ 0.59	
		1	C713 - S	C7-13 - S Screws (Set of 2) (Not Shown)	\$ 1.05	
D11	D11-2	1	C72	C7-2 Gear Housing	\$ 295.99	D11
		1	C723	C7-23 Nameplate (Front) (Not Shown)	\$ 4.39	
D11	D11-27	1	C727	C7-27 Ventura Plate	\$ 9.89	D11
D11	D11-28	1	C728	C7-28 Wheel Bracket	\$ 63.99	D11
D11	D11-29	2	C729	C7-29 Nut-Lockout	\$ 1.29	D11
D11		1	C729 - S	C7-29 - S (Set of 2)	\$ 2.29	D11
D11	D11-3	1	C73	C7-3 Gear Housing Cover	\$ 97.99	D11
D11	D11-36	1	C736	C7-36 Bag Support	\$ 16.99	D11
D11	D11-37	1	C737	C7-37 Collar	\$ 3.69	D11
D11	D11-39	4	C739	C7-39 Screw (Motor Cap) (Not Shown)	\$ 0.59	D11
D11	D11-39 - S	1	C739 - S	C7-39 - S Screw (Set of 4)	\$ 2.10	D11
D11	D11-4	1	C74	C7-4 Motor Housing Cap	\$ 68.99	D11
D11	D11-46	2	C746	C7-46 Shield	\$ 24.59	D11
D11	D11-47	4	C747	C7-47 Screw (Baffle/Vent)	\$ 0.59	D11
D11		1	C747 - S	C7-47 - S (Set of 4)	\$ 2.10	D11
D11	D11-49	2	C749	C7-49 Caster Assembly	\$ 58.99	D11
D11	D11-5	1	C75	C7-5 Lamp Shield	\$ 43.99	D11
		2	C750	C7-50 Screw (Lampshade) (Not Shown)	\$ 0.59	
		1	C750 - S	C7-50 - S Screws (Set of 2) (Not Shown)	\$ 1.05	
D11	D11-64	1	C764	C7-64 Fiber Washer	\$ 0.49	D11
D11	D11-65	1	C765	C7-65 Disc Guard Ring	\$ 47.99	D11
D11	D11-66	4	C766	C7-66 Screw (Disc Guard)	\$ 0.59	D11
D11		1	C766 - S	C7-66 - S (Set of 4)	\$ 2.10	D11
D11	D11-67	1	C767	C7-67 Disc Guard	\$ 49.99	D11
D11	D11-68	1	C768	C7-68 Disc Pad	\$ 127.99	D11
			C768 American DP	American Disc Pad (Not Shown)	\$ 127.99	
D11	11-69	1	C769	C7-69 Paper Ret. Washer	\$ 6.30	D11
D11	D11-6L	1	C76L	C7-6L Handle (Left)	\$ 65.99	D11
D11	D11-6R	1	C76R	C7-6R Handle (Right) w/Switch & Cord Hole	\$ 74.99	D11
D11	D11-7	1	C77	C7-7 Dust Tube	\$ 85.99	D11
D11	D11-70	1	C770	C7-70 Paper Ret. Bolt	\$ 4.09	D11

D11	D11-72	5	C772	C7-72 Screw (Gear Cover)	\$ 0.59	D11
D11		1	C772 - S	C7-72 (Set of 5)	\$ 2.40	
D11	D11-73	4	C773	C7-73 Screw (Dust Tube)	\$ 0.59	D11
D11		1	C773 - S	C7-73 - S (Set of 4)	\$ 2.10	
D11	D11-75	2	C775	C7-75 Wrench Clip	\$ 6.09	D11
D11	D11-75	2	C776	C7-76 Screw (Wrench Clip)	\$ 1.69	D11

D11A-2D2 DBK - Replacement Dust Brush Kit

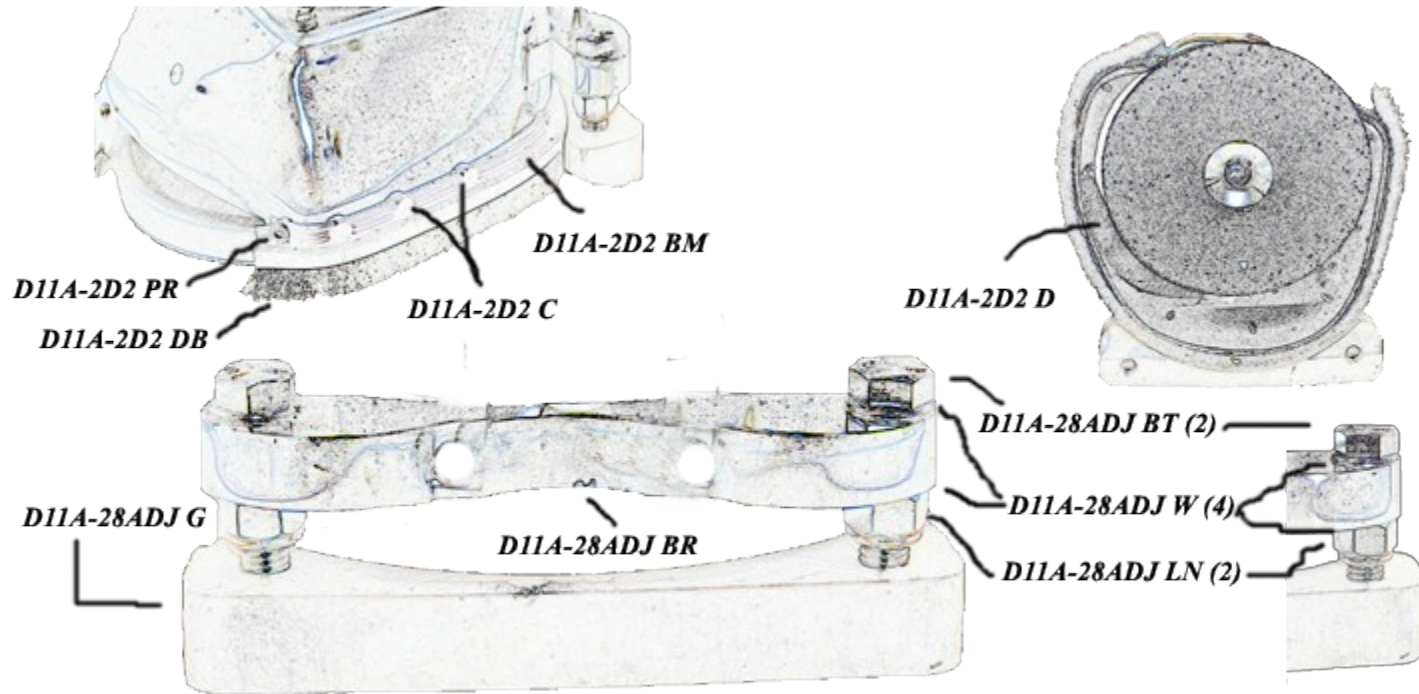

Diagram 11A

D11A-28ADJ Assm - Complete Glide/Bracket Assembly

Diagram	#	QTY	Item	Description	List Price	Diagram
D11A	D11A-2D2BM	1	C72D2BM	C7-2D2BM Brush Mount	\$ 97.99	D11A

D11A	D11A-2D2C	12	C72D2C	C7-2D2C Clips	\$ 0.89	D11A
D11A	D11A-2D2C S	1	C72D2C S	C72-D2C S (Set of 12)	\$ 8.79	D11A
D11A	D11A-2D2D	1	C72D2D	C7-2D2D Deflector	\$ 165.99	D11A
D11A	D11A-2D2DB	1	C72D2DB	C7-2D2DB Dust Brush	\$ 66.99	D11A
D11A	D11A-2DPR	2	C72D2PR	C7-2D2PR Pop Rivets	\$ 1.29	D11A
D11A	D11A-2DPR - S	1	C72D2PR S	C7-2D2PR S (Set of 2)	\$ 2.48	D11A
	D11A-2D2 DBK	1	C72D2 DBK	C7-2D2 DBK Dust Brush Replacement Kit	\$ 77.99	
D11A	D11A-28ADJ BR	1	C728ADJ BR	C7-28 Bracket for SL7D2	\$ 63.99	D11
D11A	D11A-28ADJ BT	2	C728ADJ BT	C7-28ADJ BT Bolt for SL7D2	\$ 2.48	D11
D11A	D11A-28ADJ BT - S	1	C728ADJ BT S	C7-28ADJ BT S (Set of 2)	\$ 4.89	D11
D11A	D11A-28ADJ G	1	C728ADJ G	C7-28ADJ G Glide for SL7D2	\$ 80.99	D11
D11A	D11A-28ADJ LN	2	C728ADJ LN	C7-28ADJ LN Lock Nut for SL7D2	\$ 1.29	D11
D11A	D11A-28ADJ LN - S	1	C728ADJ LN	C7-28ADJ LN (Set of 2)	\$ 2.48	D11
D11A	D11A-28ADJ W	4	C728ADJ W	C7-28ADJ W Flat Washer for SL7D2	\$ 0.49	D11
D11A	D11A-28ADJ W -S	1	C728ADJ W S	C7-28ADJ W S (Set of 4)	\$ 1.89	D11
	D11A-28ADJ Assm	1	C728ADJ Assm	C728ADJ Assem (Glide/Bracket Assm)	\$ 171.99	

D11A-2D2 DBK - Replacement Dust Brush Kit

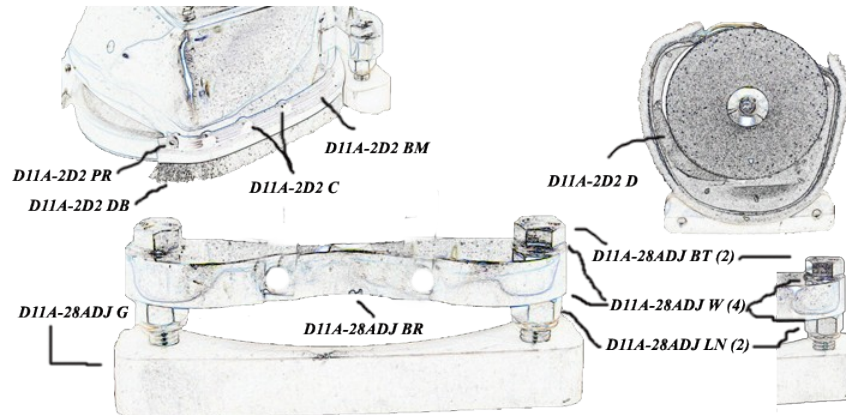

Diagram 11A D11A-28ADJ Assm - Complete Glide/Bracket Assembly

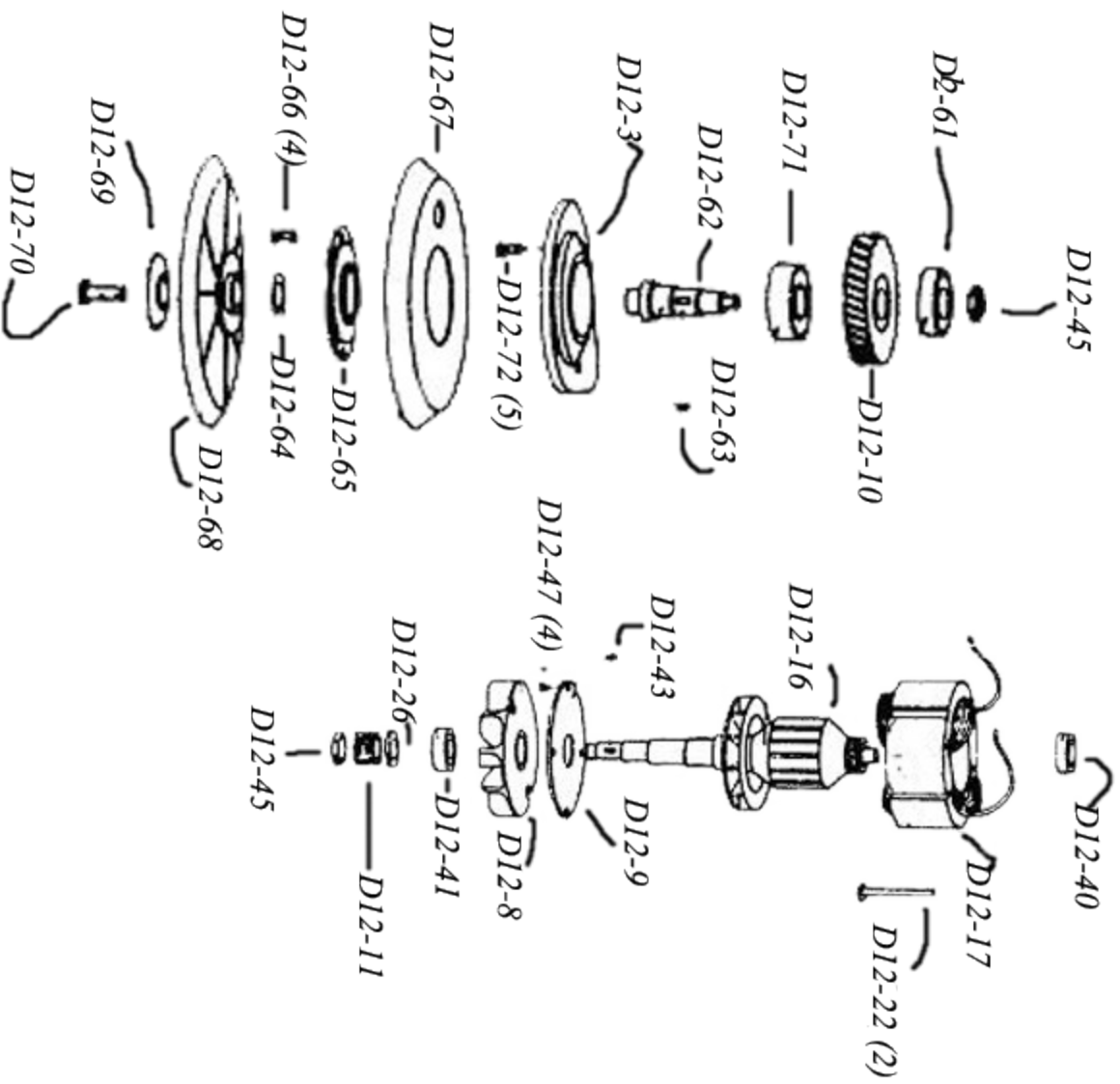

Diagram 12

Diagram	#	QTY	Item	Description	List Price	Diagram
---------	---	-----	------	-------------	------------	---------

D12	D12-10	1	C710	C7-10 Large Gear	\$ 164.99	D12
D12	D12-11	1	C711	C7-11 Small Gear	\$ 59.99	D12
D12	D12-16	1	C716	C7-16 Armature (110 Volt)	\$ 270.99	D12
			C716240	C7-16 Armature (240V-50HZ)	\$ 291.99	
D12	D12-16		C716A	C7-16A Armature w/baffle & Vac Fan (Not Shown)	\$ 344.99	D12
D12			C716B	C7-16B Cooling fan (Press on)	\$ 29.99	D12
D12	D12-17	1	C717	C7-17 Field (110 Volt)	\$ 118.99	D12
			C717240	C7-17 Field (240V-50HZ)	\$ 127.99	
D12	D12-22	2	C722	C7-22 Screw (field)	\$ 1.05	D12
D12		1	C722 - S	C7-22 - S (Set of 2)	\$ 1.89	D12
D12		2	C722A	C722A #10 Lock Washer (Field screw) (Not Shown)	\$ 0.20	D12
D12		1	C722A - S	C722A - S (Set of 2)	\$ 0.36	D12
D12	D12-26	1	C726	C7-26 Spacer (New Style)	\$ 10.99	D12
D12	D12-3	1	C73	C7-3 Gear Housing Cover	\$ 97.99	D12
D12	D12-40	1	C740	C7-40 Bearing #1 (Comm) #6201	\$ 17.99	D12
D12	D12-41	1	C741	C7-41 Bearing #2 (Fan End) #6202	\$ 18.99	D12
D12	D12-43	1	C743	C7-43 Key (Small Gear)	\$ 1.59	D12
D12	D12-45	1	C745	C7-45 Nut (Left Handed)	\$ 6.99	D12
D12	D12-47	4	C747	C7-47 Screw (Baffle/Vent)	\$ 0.59	D12
D12		1	C747 - S	C7-47 - S (Set of 4)	\$ 2.10	D12
D12	D12-61	1	C761	C7-61 Bearing #3 (Upper Jack Shaft) #6203	\$ 17.99	D12
D12	D12-62	1	C762	C7-62 Jackshaft w/key	\$ 89.99	D12
D12	D12-63	1	C763	C7-63 Key	\$ 1.58	D12
D12	D12-64	1	C764	C7-64 Fiber Washer	\$ 0.49	D12
D12	D12-65	1	C765	C7-65 Disc Guard Ring	\$ 47.99	D12
D12	D12-66	4	C766	C7-66 Screw (Disc Guard)	\$ 0.59	D12
D12		1	C766 - S	C7-66 - S (Set of 4)	\$ 2.10	D12
D12	D12-67	1	C767	C7-67 Disc Guard	\$ 49.99	D12
D12	D12-68	1	C768	C7-68 Disc Pad	\$ 127.99	D12
D12	D12-69	1	C769	C7-69 Paper Ret. Washer	\$ 6.30	D12
D12	D12-70	1	C770	C7-70 Paper Ret. Bolt	\$ 4.09	D12
D12	D12-71	1	C771	C7-71 Bearing #4 (Lower Jackshaft) 6204	\$ 17.99	D12
D12	D12-72	5	C772	C7-72 Screw (Gear Cover)	\$ 0.59	D12
D12		1	C772 - S	C7-72 - S (Set of 5)	\$ 2.40	D12
D12	D12-8	1	C78	C7-8 Vacuum Fan	\$ 46.99	D12
D12	D12-9	1	C79	C7-9 Baffle Plate	\$ 19.99	D12

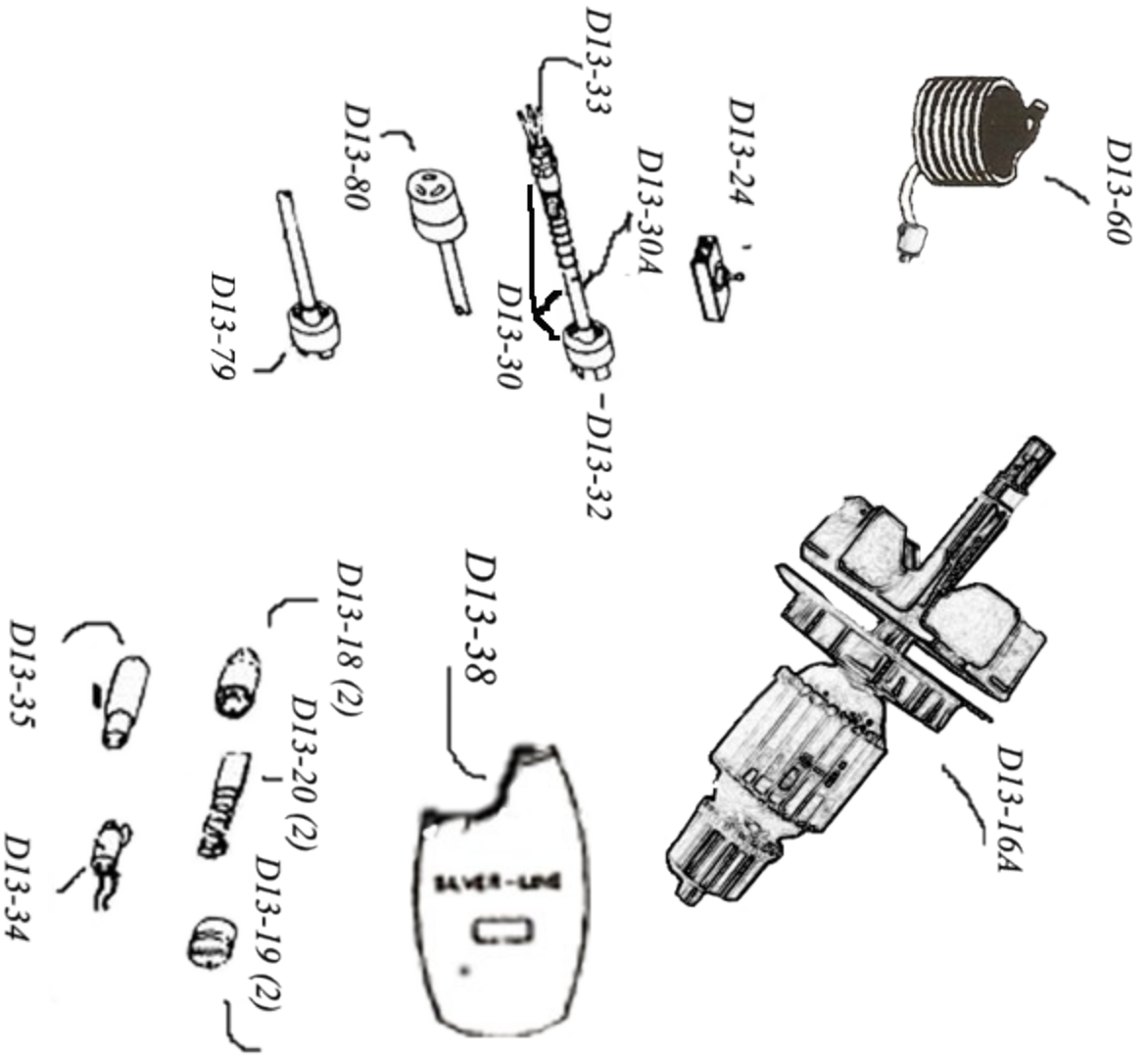

Diagram 13

Diagram	#	QTY	Item	Description	List Price	Diagram
D13	D13-16A	1	C716A	C7-16A Armature w/baffle & Vac Fan	\$ 344.99	D13
D13	D13-18	2	C718	C7-18 Brush Holder	\$ 15.99	D13
D13		1	C718 - S	C7-18 - S (Set of 2)	\$ 27.99	D13
D13	D13-19		C719	C7-19 Brush Cap	\$ 3.69	D13
D13		1	C719 - S	C7-19 - S (Set of 2)	\$ 6.69	D13
D13	D13-20		C720	C7-20 Brush (ea.)	\$ 12.99	D13
D13		1	C720 - S	C7-20 - S (Set of 2)	\$ 22.99	D13
D13	D13-24	1	C724	C7-24 Switch	\$ 23.99	D13
D13	D13-30	1	C730	C7-30 Short Cord Ass.(30,30A,32,33)	\$ 45.99	D13
D13	D13-30A		C730A	C7-30A Short Cord Only	\$ 8.99	D13
D13			C731	C7-31 Cord Only (25FT) w/ Male Plug (Not Shown)	\$ 45.99	D13
D13	D13-32	1	C732	C7-32 Plug (Male twist)	\$ 14.99	D13
D13	D13-33	1	C733	C7-33 Strain Reliever	\$ 16.99	D13
D13	D13-34	1	C734	C7-34 Lamp Socket	\$ 9.89	D13
D13	D13-35	1	C735	C7-35 Lamp (50/Box)	\$ 2.39	D13
D13	D13-38	1	C738	C7-38 Dust Bag	\$ 25.99	D13
D13			C738R	C7-38R Dust Bag (Reinforced) (Not Shown)	\$ 27.99	D13
D13	D13-60	1	C760	C7-60 Cord Complete	\$ 59.99	D13
D13	D13-74	2	C774	C7-74 Screw (Brush Holder) (Not Shown)	\$ 0.49	D13
D13	D13-79	1	C779	C7-79 plug (Male Straight)	\$ 13.99	D13
D13	D13-80	1	C780	C7-80 Body (Female Twist)	\$ 22.99	D13

Essex Silver-Line Corporation

1118 Lakeview Ave

PO Box 40

Dracut, MA 01826

Phone (978) 957-2116, Fax (978) 957-6989, Toll Free 800 451-5560

Visit us on the World Wide Web at:

www.essex-silver-line.com

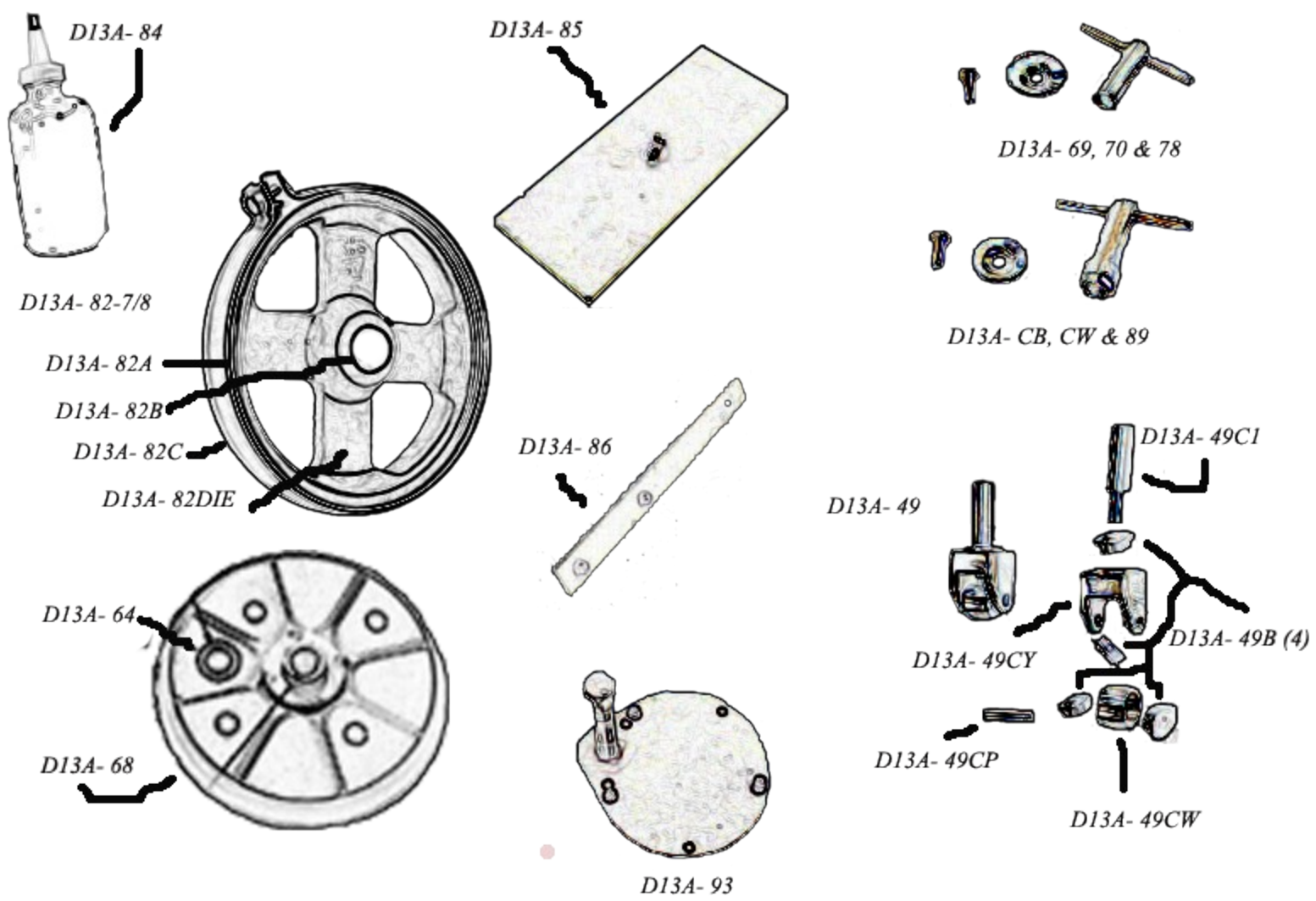

Diagram 13A Misc Parts

Diagram	#	QTY	Item	Description	List Price	Diagram
			C70	C7-0 SL7 Carrying Box (Wood Tote - Not Shown)	\$ 114.99	
		1	C742	C7-42 Grease Plug	\$ 5.99	
D13A	D13-49C1		C749C1	C7-49C1 Stem	\$ 24.99	D13A
D13A	D13-49CB		C749CB	C7-49CB Caster Bearing	\$ 10.99	D13A
D13A	D13-49CP		C749CP	C7-49CP Edger Caster Roll Pin	\$ 3.59	D13A
D13A	D13-49CW		C749CW	C7-49CW Caster Wheel	\$ 18.99	D13A
D13A	D13-49CY		C749CY	C7-49CY Yoke	\$ 34.99	D13A
			C751	C7-51 Handle/Lamp Shield Screw/Washer Set (Not Shown)	\$ 6.99	
			C7TAUS	C7-7AUS Dust Tube with/Elec Box - Australia (Not Shown)	\$ 131.99	
			C7TAUS-EMI	C7-7AUS-EMI Filter	\$ 39.99	
D13A	D13A-69	1	C769	C7-69 Paper Retaining Bolt	\$ 6.30	D13A
D13A	D13A-70	1	C770	C7-70 Paper Retaining Washer	\$ 4.09	D13A
D13A	D13A-78	1	C778	C7-78 Edger Wrench	\$ 18.99	D13A
D13A			C782	C7-82 Disc Cutter (5/16" CH) (Not Shown)	\$ 117.99	D13A
D13A	D13-82 - 7/8		C782 - 7/8	C782 - 7/8	\$ 117.99	D13A
D13A	D13-82A		C782A	C7-82A Cutter Blade	\$ 14.99	D13A
D13A	D13-82B		C782B	C7-82B Center Punch (Specify 5/16" or 7/8")	\$ 12.99	D13A
D13A	D13-82C		C782C	C7-82C Disc Cutter Ret. Strap	\$ 15.99	D13A
D13A	D13-82DIE		C782die	Disc Cutter Die Only	\$ 52.99	D13A
D13A	D13-84	1	C784	C7-84 Grease (One Shot Tube) 4 oz.	\$ 12.69	D13A
D13A	D13-85		C785	C7-85 Gear Housing Cover/Jackshaft Tool	\$ 29.99	D13A
D13A	D13-86		C786	C7-86 Tool/Remove Disc Pad (Not Shown)	\$ 21.99	D13A
			C787	C7-87 Adjusting Bars for SL7 Caster	\$ 17.99	
			C788	C7-88 Clarke Disc Spacer (Not Shown)	\$ 9.99	
D13A	D13A-89		C789	C7-89 Clarke Edger Wrench	\$ 21.99	D13A
			C790	C7-90 Qt of Edger Grease (Not Shown)	\$ 25.99	
			C791	C7-91 White Nylon Washers (Not Shown)	\$ 0.19	
			C792	C7-92 Tool Repair Kit (C784, 85, 86, 87)	\$ 57.99	
D13A	D13-93		C793	C7-93 Motor/Gear Housing Separator Tool	\$ 77.99	D13A

Essex Silver-Line Corporation Limited One-Year Warranty

Essex Silver-Line Corporation warrants the floor sanding equipment for a period of one year from the date of original purchase. We will repair or replace at our option, any part or parts of the products under this warranty which examination proves to be defective in workmanship or materials during the warranty period. For repair, return machine or parts to Essex Silver-Line Corporation transportation prepaid. This warranty does not apply to repair or replacement required due to misuse, abuse, normal wear and tear and/or repairs attempted or made by other than our service center. For the purpose of this warranty, damage resulting from accident, use of defective or inadequate wiring at the installation in which used, improper cleaning or operation, fire, floods or act of God, are not covered. No other warranty implied or expressed is offered and under no circumstances shall Essex Silver-Line Corporation be liable for an incidental or consequential damage.