



Signature Stage Deck Instructions



Site Preparation

- Determine the exact location where the stage will be erected.
- For outdoor stages, mudsills are required to distribute the weight of 125psf on the stage legs. This will prevent the legs from sinking and ease the leveling of the stage.
- All base pads and mudsills should be placed only on a horizontal surface.

Leg Assembly

- The leg sockets on the stage sections fit 1-3/4" square stage legs

Assemble legs as shown either as illustration #1 or #2, the telescoping legs must not exceed the 6" minimum overlap.

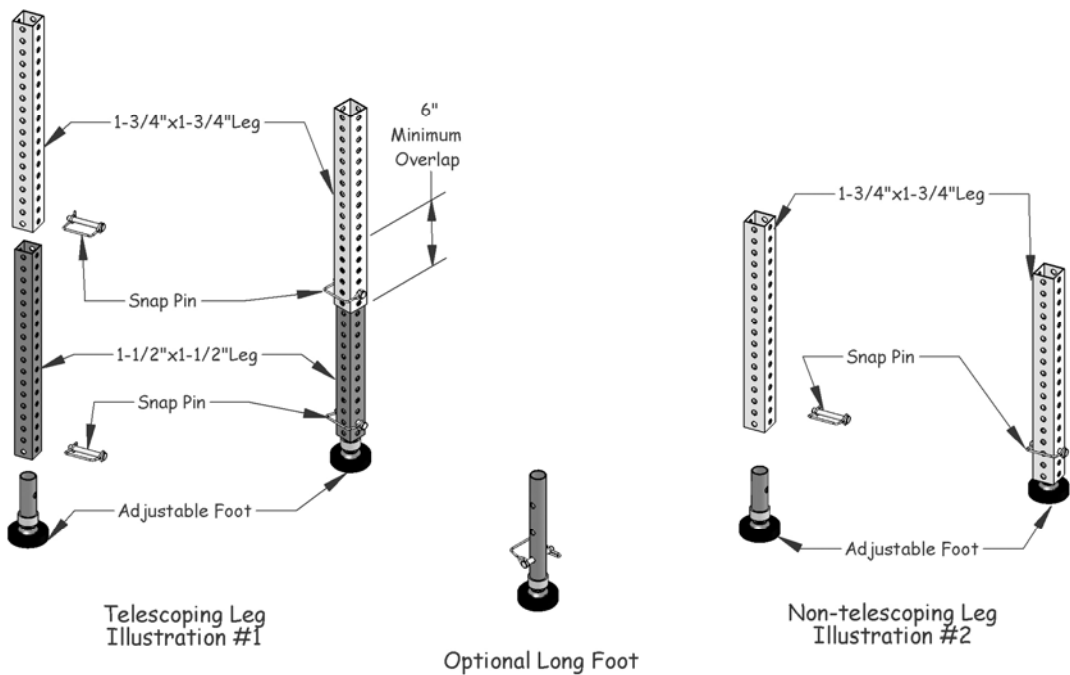

Setting the Stage

- Insert legs completely into all four corner sockets on first stage section and tighten thumb screw which holds leg into deck.



Setting the Stage continued

- Set first section in back left-hand corner of stage area. Note: any corner may be used as starting point. (the first deck is referred to as the starter deck)
- Align the stage section so that the connecting fingers are to the inside and the smooth sides are to the outside of the stage area.
- Set back row of stages first.
- Insert two legs into stage sections as you work your way along the back row, attaching each deck to the previous one back setting them together using the connecting fingers.
- Upon completion of the back row, begin the second row with one section with two legs.
- To continue the second row, insert one leg into corner socket, then set the deck into the connecting fingers onto both deck.

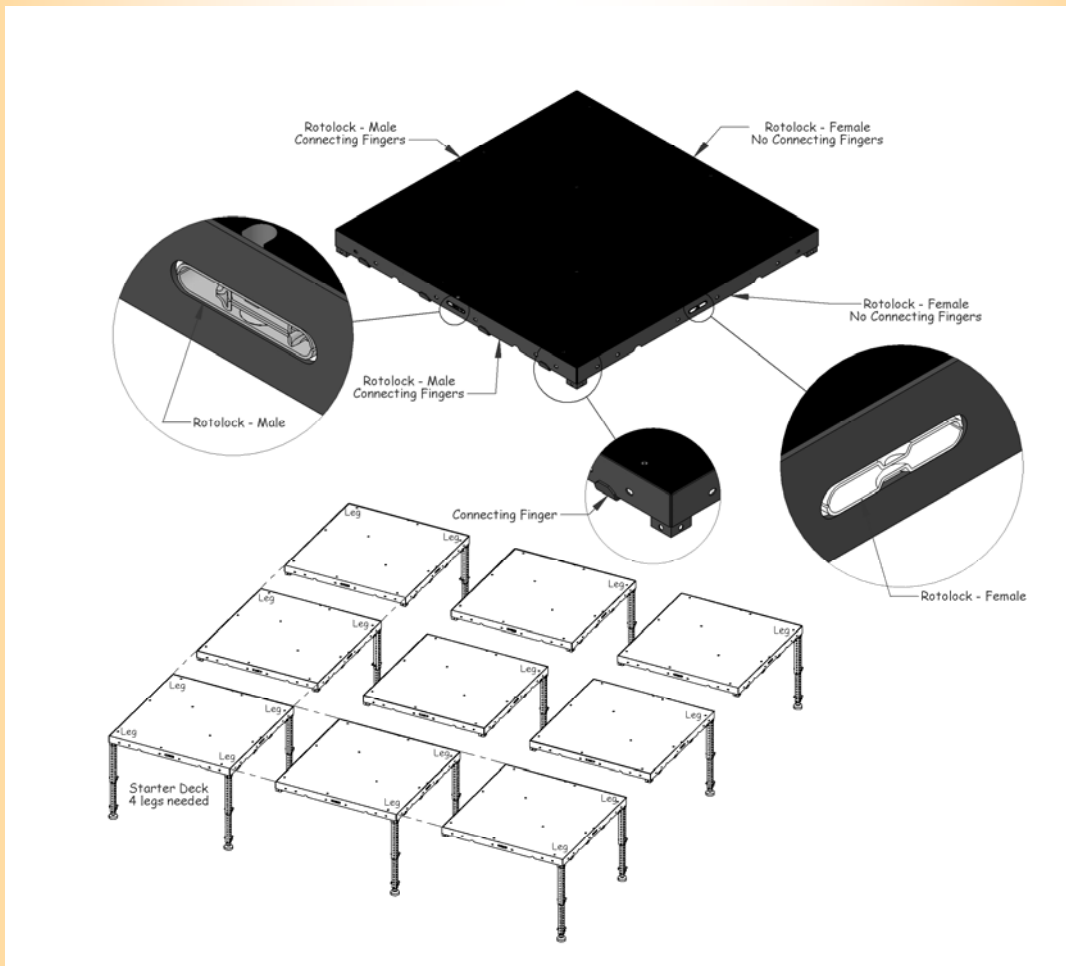

Locking Stage Decks Together

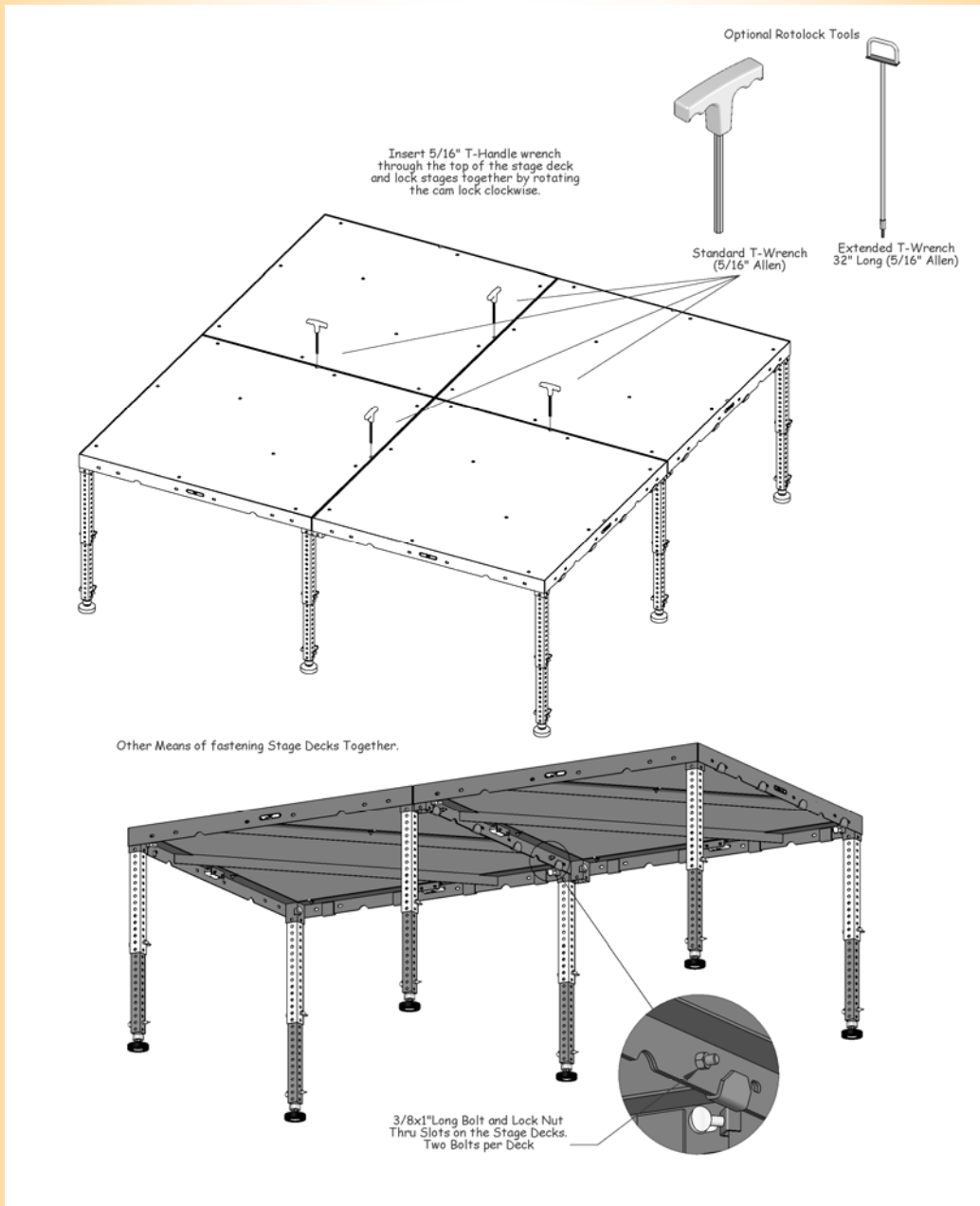

Diagonal Bracing

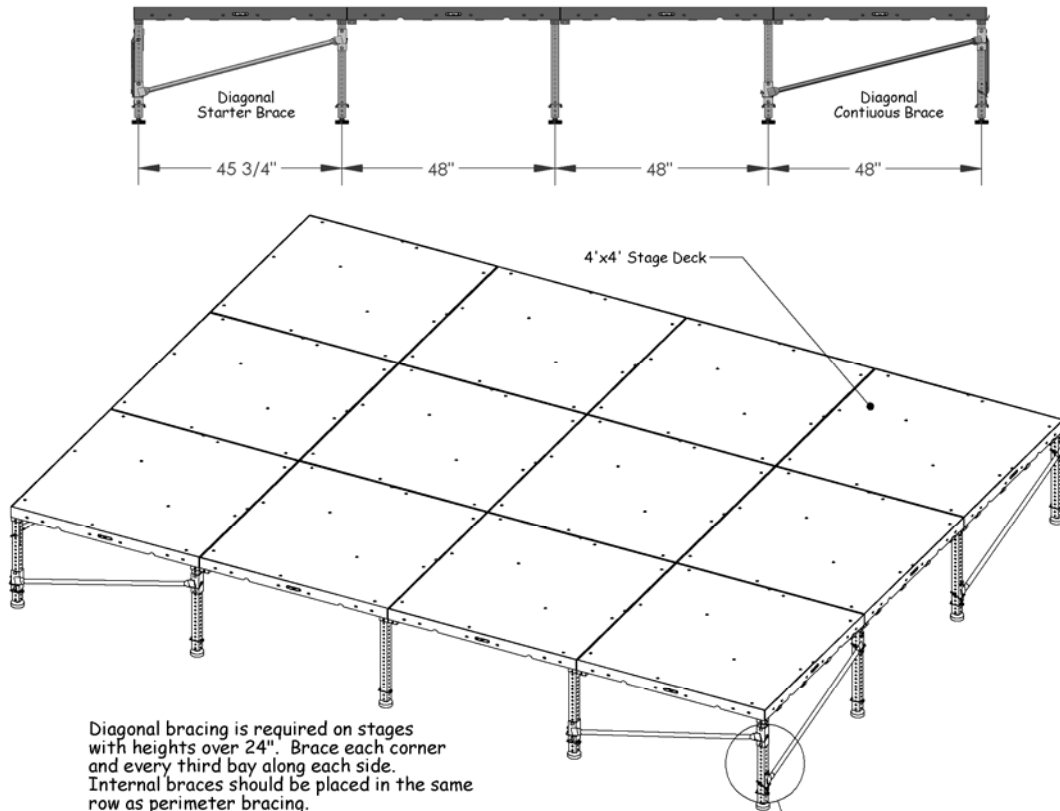

Diagonal bracing is required on stages with heights over 24". Brace each corner and every third bay along each side. Internal braces should be placed in the same row as perimeter bracing.

Double diagonal bracing should be used on heights over 48". At least one of the braces should span the connection between the 1-1/2" and the 1-3/4" telescoping sleeve.

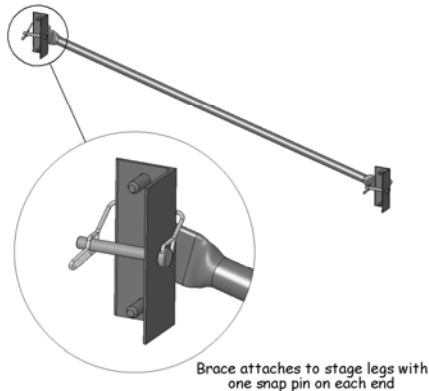

Diagonal Bracing
Top View

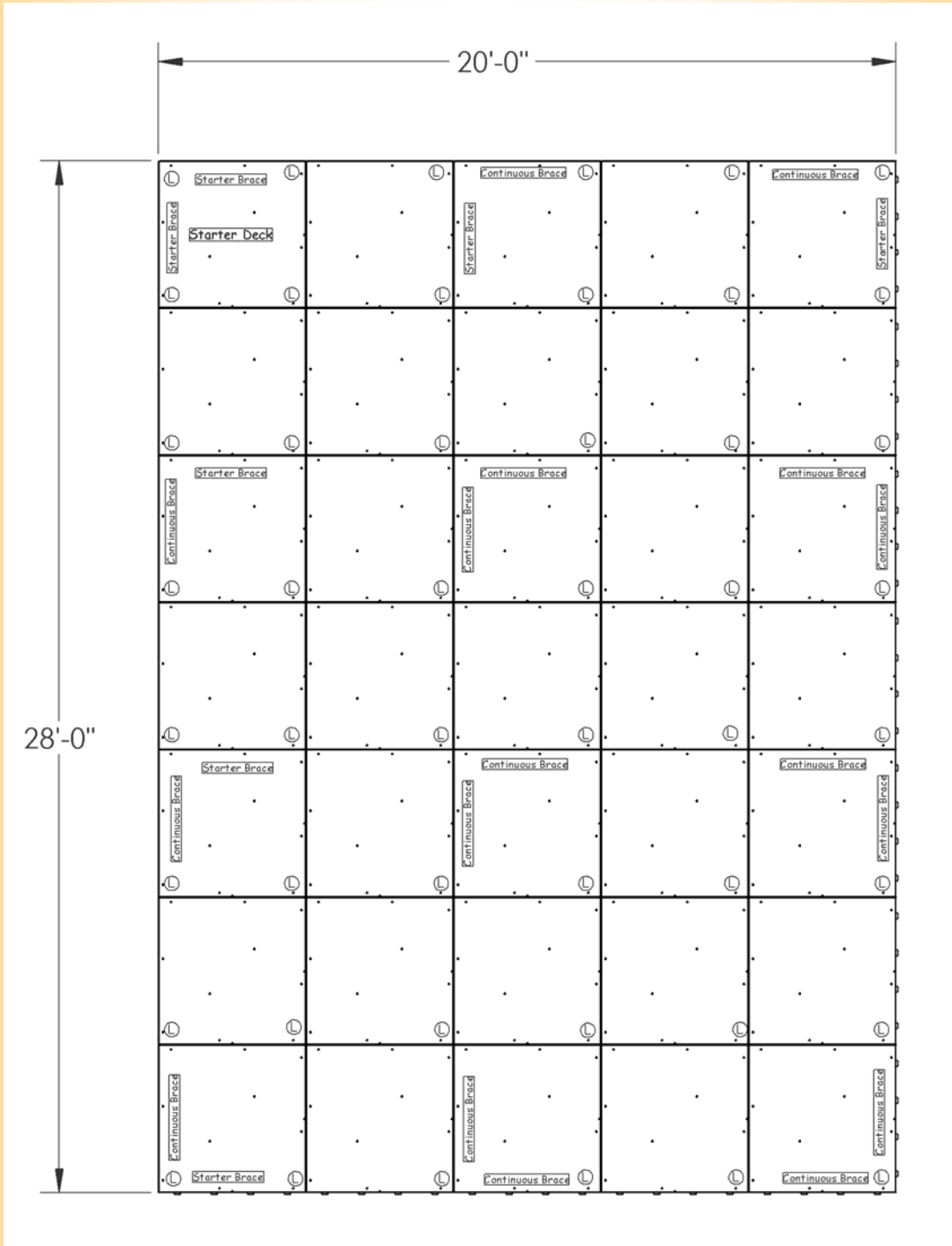

Stair Handrail

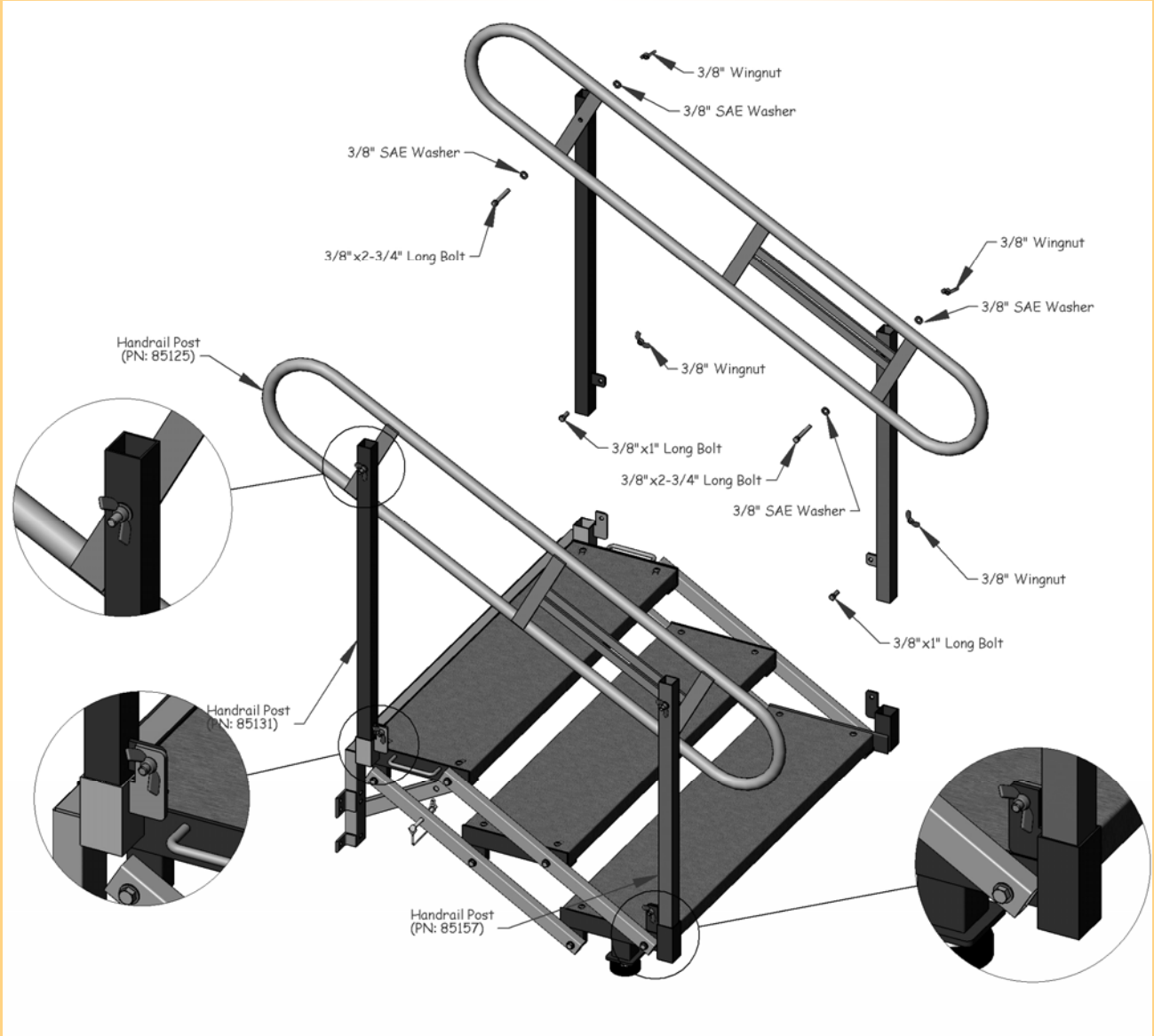

Stair Installation

STAIR ATTACHED TO 45-3/4" LEG SPACING DECK

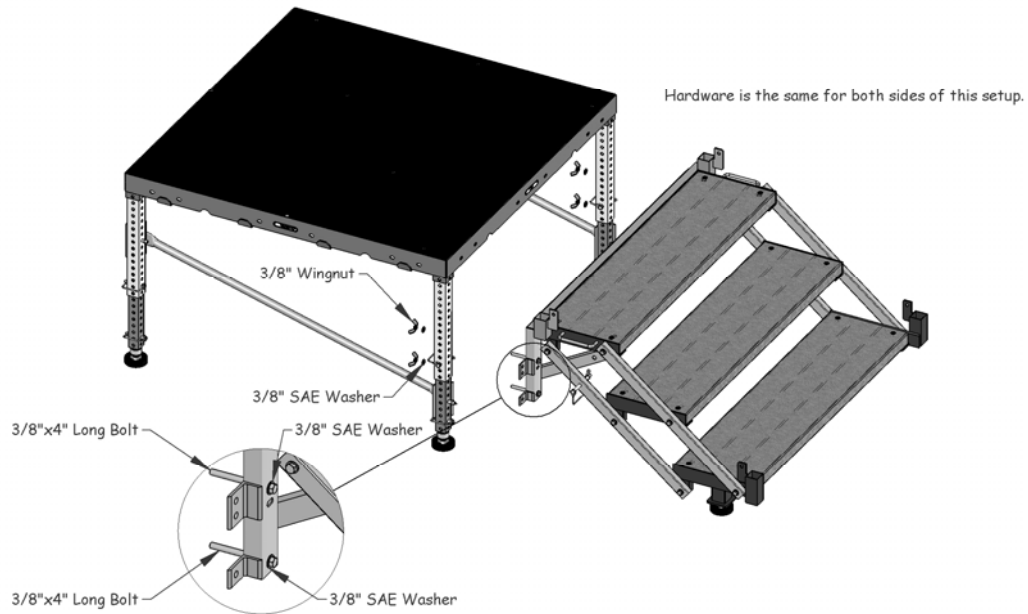

STAIR ATTACHED TO 48" LEG SPACING DECK

