

FORCE/1



Instruction Manual

3771 Monarch Street • Frederick, CO 80530 • www.inteccorp.com
Local: (303) 833-6644 • Fax: (303) 833-6650 • Toll Free: (800) 666-1611

THE FORCE/1

Table of Contents

Machine Information	2
Contacting Intec	3
Introduction	4
Overview	5
How The System Works Together	10
Safety First	11
Set-Up & Operation	12
Operational Guidelines	16
Sidewalls & Insulation Material	18
Generators and Extension Cords	20
Maintenance	21
Troubleshooting	29
Mechanical Drawings.....	33
Electrical Drawings.....	39
Claims, Damage or Loss	44
Returns	46
Replacement Parts	47
Warranty	48
Insulation Terms And Values	49

MACHINE INFORMATION

THE FORCE / 1

Contacting Intec

Phone support:

Available Monday - Friday, excluding holidays. In the United States and Canada, call (800) 666-1611, 7:00 A.M. to 5:00 P.M. Mountain Time. Ask for technical support and one of our technicians will be glad to help you.

On-site/off-site repair support:

Available Monday to Friday, excluding holidays. In the United States and Canada, call (800) 666-1611, 7:00 A.M. to 5:00 P.M. Mountain time. For the latest repair/service centers across the United States visit our web site, www.inteccorp.com and go to service centers. All service centers are independently owned and operated and are not part of Intec. Consult the nearest service center for the hours of operation and lead time for repair.

Website support:

Visit our web site 24/7 at www.inteccorp.com and go to the specific model your wanting information on, then go to the technical bulletins section. The technical section of the web site is constantly being updated with new information and technical documents. If you cannot find what you are looking for please contact us Monday - Friday, excluding holidays, in the United States and Canada, call (800) 666-1611, 7:00 A.M. to 5:00 P.M. Mountain Time. Ask for technical support and one of our technicians will be glad to help you.

Contact Information:

3771 Monarch Street

Frederick, CO 80530

Ph: 1-303-833-6644

1-800-666-1611

Fax: 1-303-833-6650

E-mail: info@inteccorp.com

THE FORCE/1 *Insulation Blowing Machine*

Your FORCE/1 insulation blowing machine, the product of years of laboratory and field testing, offers both the contractor and the homeowner exceptional performance, total reliability, and ease of use.

It is designed and built to blow-in more than 500 pounds of material per hour. No other machine in its class can match the performance of the FORCE/1.

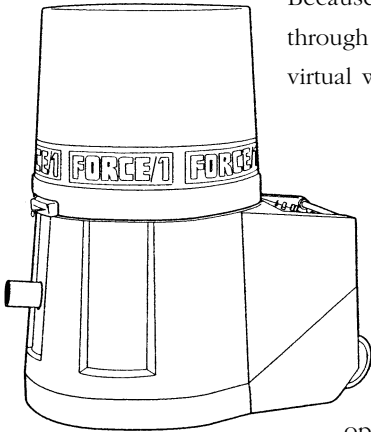

Because no insulation actually goes through the blower, the FORCE/1 is a virtual workhorse, requiring only minimal maintenance and almost no downtime. The direct drive feature also means there are no chains for you to adjust or replace, ever.

By following the instructions in this manual, setting up and operating the FORCE/1 on your jobsite will be uncomplicated, quick, safe, and easy. Once your work is finished, end-of-the-day clean up is equally efficient.

Exceptional performance. Total reliability. Ease of use. Those are the reasons why the FORCE/1 was your best choice.

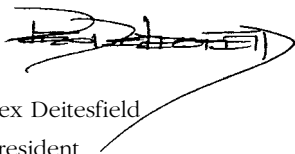

Rex Deitesfield
President

THE FORCE / 1

Overview

Height	41"
Width	32 - ¼"
Weight	177 lbs.
Hopper Capacity	25 lbs.
Hose Size	2- ½"
Blower	104 CFM, 2.5 PSI (AVG) 8 amps
Agitator Motor	¾ hp - 9.5 amps, 115 VAC
Gearbox	Custom, direct drive
Airlock	6- ½" x 7-¼" opening, steel, 6-vane, cast urethane seals
Electric	115V/20 amp 50/60Hz 220V/10 amp 50/60Hz (optional)
Agitator	3-vane
Wheels	6"
Warranty	One year limited; 90 days limited on electric, blower and airlock system

Specifications are subject to change without notice.

THE FORCE/1

Overview

Three subsystems make up your FORCE/1:

THE AGITATOR AND AIRLOCK. Your FORCE/1 runs on a $\frac{3}{4}$ horsepower motor driving an enclosed gearbox. The airlock positions the material for proper distribution by the blower.

THE BLOWER MOTOR. Your FORCE/1 is equipped with a 104 CFM two-stage blower motor to push the material through the hose and into the attic with optimum pressure and output. The blower is connected to the air intake port of the airlock by a metal sleeve.

ELECTRICAL COMPONENTS. Your FORCE/1 requires a dedicated 20 amp grounded power supply. Less amperage will likely trip circuit breakers. Always disconnect the power source before beginning any maintenance. And as with all electrical systems, never attempt to operate your FORCE/1 with either the operator or the machine standing in water.

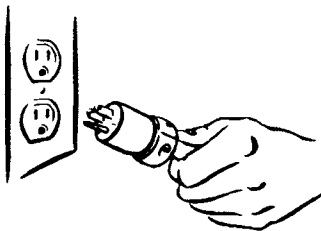

THE PARTS (see next page for drawings)

- A. Hopper: upper component of the FORCE/1 where insulation is loaded.
- B. Base: lower component of the FORCE/1 houses power components, blower and airlock.
- C. Slide gate: increases or decreases the amount of material entering the airlock.
- D. Electrical: on/off function of both the blower and agitator motors.

THE FORCE/1

Overview

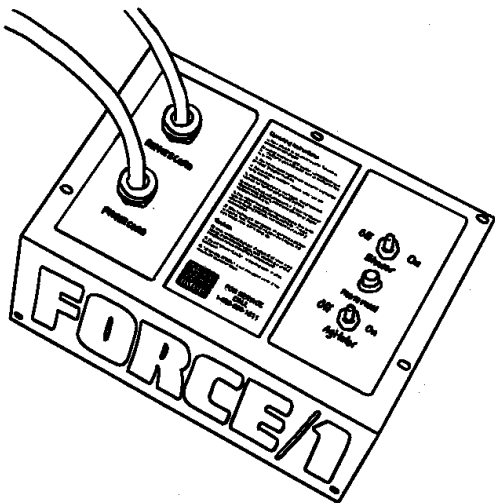
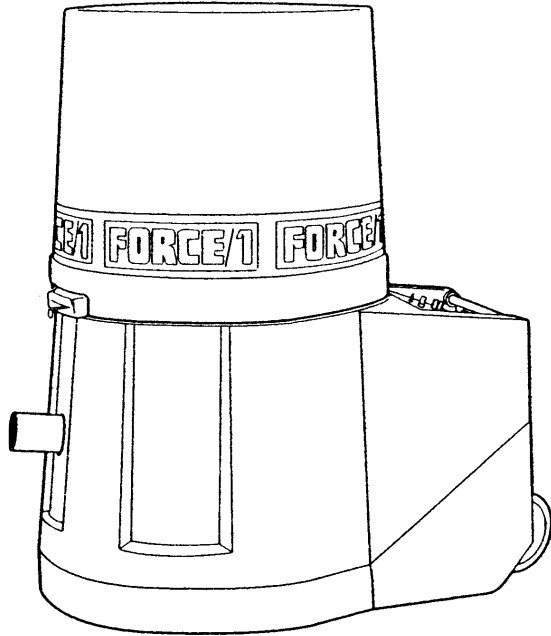

Example only see page 43 for specific electrical systems.

THE FORCE/1

Overview

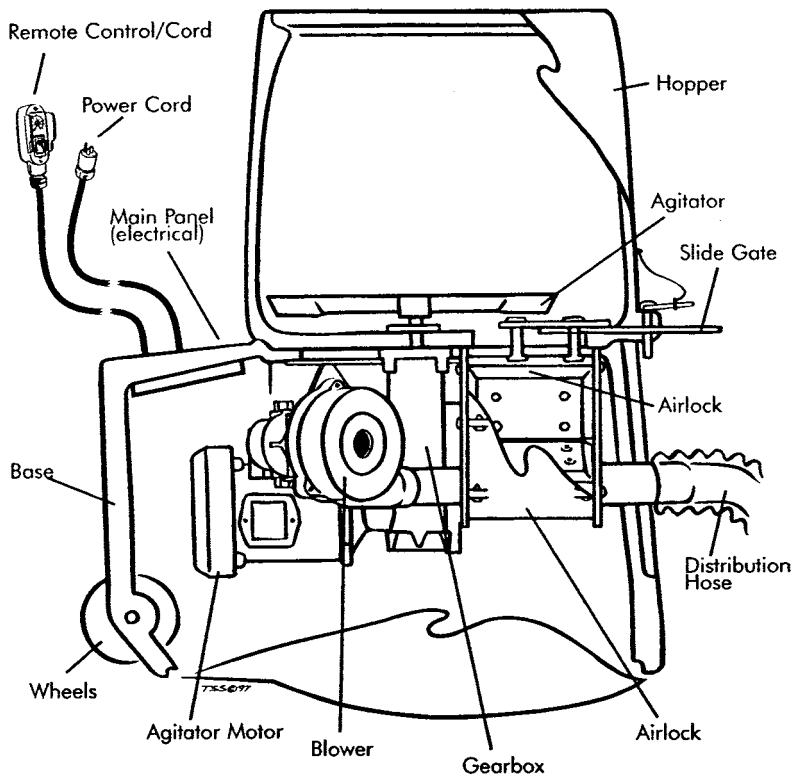

THE FORCE/1

Overview

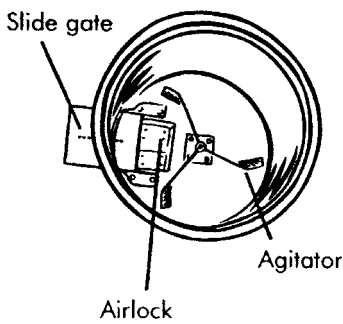
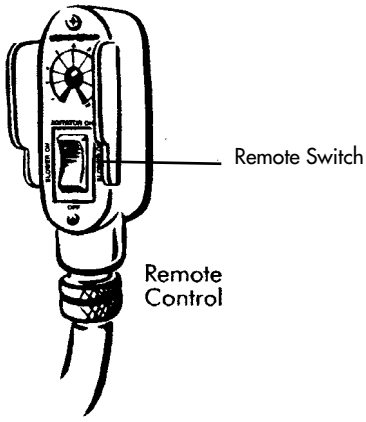
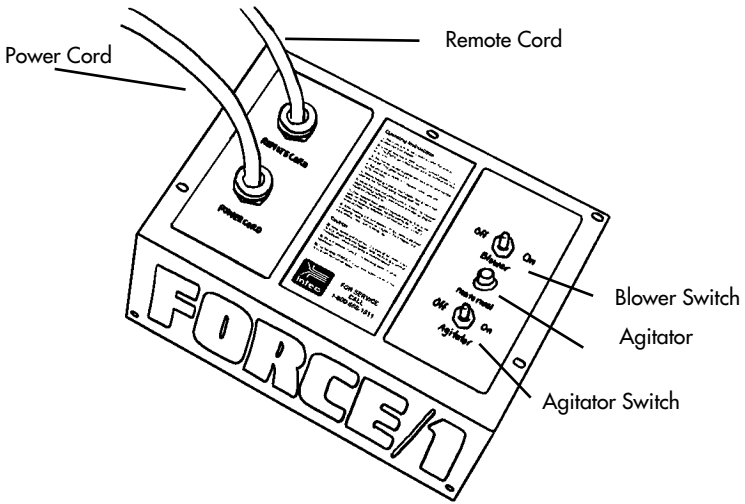

THE FORCE/1

How the System Works Together

AGITATOR: a unique system expands and conditions the insulation to an optimum configuration, then sweeps the material into the airlock for distribution through the hose.

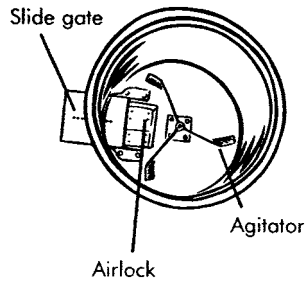

AGITATOR MOTOR: drives the gearbox. No maintenance is required. Produces $\frac{3}{4}$ HP, 115 VAC.

AIRLOCK: moves the conditioned material from the agitator into the air flow from the blower. The airlock seals must be inspected regularly and kept in good working order for the FORCE/1 to operate efficiently.

BLOWER: creates the airflow which propels the material from the airlock into the hose for distribution. No insulation material passes through the blower. The blower moves 104 CFM drawing eight amps, 115 VAC. See the maintenance section for required service.

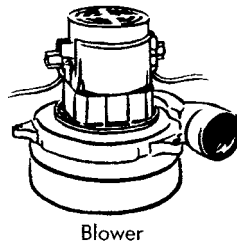

GEARBOX: running both the airlock and agitation system, the gearbox requires periodic maintenance, including changing the oil at least once a year. See the maintenance section for more details about changing the gearbox oil. If you are working in cold weather, changing to Mobil 1 or 5W-30 high performance synthetic oil will aid start-ups. In addition, inspect the gearbox and airlock alignment regularly. Normal alignment is perpendicular to each other, preventing excess wear on the airlock and shaft connection. See the maintenance section for more details.

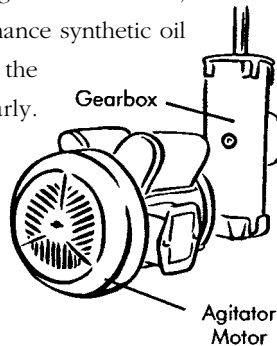

THE FORCE/1

Safety First

When working with insulation, always wear a long sleeve shirt, gloves, a hat, goggles or safety glasses for eye protection and a 3M brand #8710 nose/mouth filter (or equivalent) for respiratory protection.

ACCESSORIES YOU NEED TO WEAR...

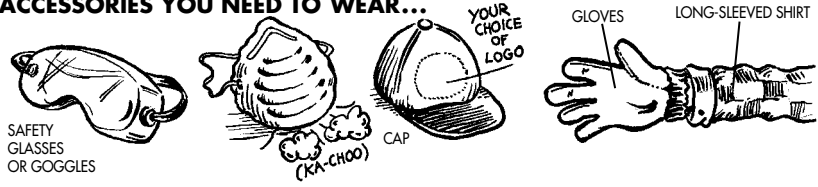

- Never put your hands into the hopper while the machine is running.
- Keep tools and other foreign objects out of the hopper. Clean all material out of the hopper and the hose when your job is complete.
- Never leave your machine unattended while it is running. Turn "off" and disconnect power before taking a break.
- Never operate your machine if it or the operator is standing in water. Serious injury may result.

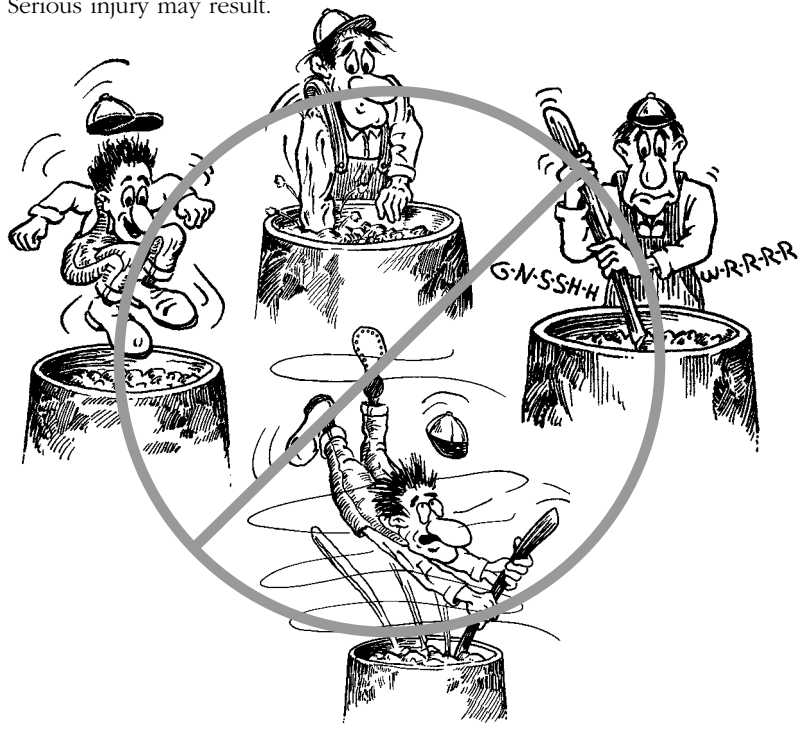

SAFETY FIRST

THE FORCE/1

Set-Up and Operation

REMOTE CONTROL: permanently attached to the main panel, the remote allows operation from the attic. Both the agitator and the blower can be operated by the remote control.

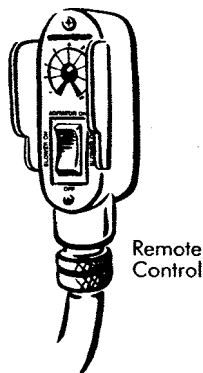

Remote Control

ELECTRICAL CONNECTIONS: Before connecting the machine to electrical power, make sure all switches are in the “off” position. Connect the supplied extension cord to a dedicated 115V 20 amp grounded outlet. In the home,

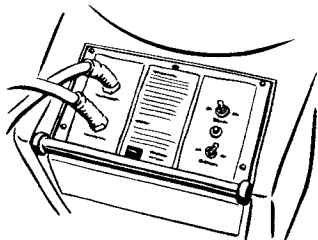

Main Panel

refrigerator or freezer outlets usually fit the amperage requirements. If necessary, these appliances can be temporarily unplugged, enabling the FORCE/1 to use the outlet. Disconnecting these appliances for the short time needed to operate the FORCE/1 will not cause spoilage. Remember

to reconnect any unplugged appliance after the job is finished. If your job requires additional extension cords, make sure you use only a 12/3 cord for a 50 foot run or 10/3 cord for a 100 foot extension.

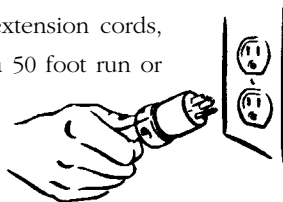

STARTING:

To operate the FORCE/1 from the ground, the rocker switch on the remote control must be in the “on” position. Operate the blower and agitator from the main electrical panel toggle switches. To use the remote control feature for attic operation, the switches on the main panel must be “on”; you will control the machine with the rocker switch on

THE FORCE/1

Set-Up and Operation, Cont.

the remote cord. In cold weather, your machine is more difficult to start. If possible, store your FORCE/1 in a warm area overnight before starting.

DISTRIBUTION HOSE: For normal attic applications, the two and a half inch hose produces the best results. Always use at least 100 feet of hose on your job. Longer hose length decreases both capacity and material throw. At 200 feet of hose, capacity and throw will be reduced by approximately 30%. If you must use a hose longer than 150 feet, reduce the hose size to two inch diameter.

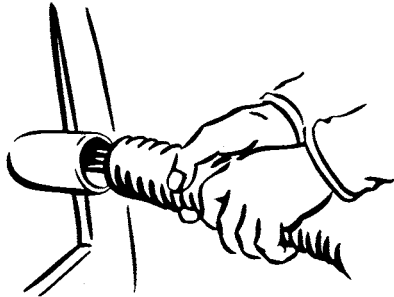

Distribution Hose

HOPPER SAFETY:

Your safety is the most important consideration whenever you are using any machine. Following the instructions in this manual, along with good common sense, should allow you to complete your job in a safe, efficient manner. First, before loading your FORCE/1, follow all safety considerations provided by the manufacturer of the insulation material you are using, including wearing protective masks or respirators. Never wear loose clothing or other items while running this machine. Failure to follow safety precautions may result in permanent injury

Any time you overload the hopper, or anytime you place objects other than insulation material into the hopper, you are risking personal injury or equipment breakdown.

THE FORCE/1 *Set-Up and Operation, Cont.*



Overloading the hopper or pushing down on the material in the hopper can cause electrical problems or jamming which can damage your machine. When loading your machine, empty only one bag at a time into the hopper. Wait until half the contents have been used before adding another bag.

Always clean unused material out of the hopper, airlock, and hose at the end of each job.

Do not put your hands inside the hopper while the machine is running. If a tool or other foreign object accidentally falls into the hopper, turn the machine off immediately. Careless operation of this machine can result in bodily injury.

ADJUSTING SLIDE GATE:

The pin-set slide gate regulates the amount of material entering the airlock. By adjusting the slide gate, you increase or decrease both the amount of material and the material throw distance from the hose. To increase material flow, pull the slide gate out; to decrease push the slide gate in.

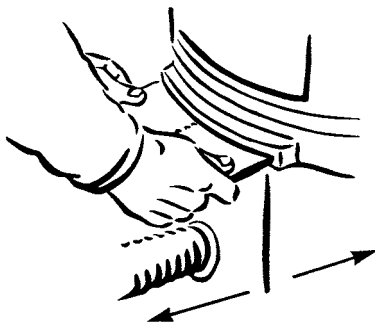

Slide Gate Adjustments

THE FORCE/1

Set-Up and Operation, Cont.

LOADING THE HOPPER: Machine may be “on or off” while loading. **Cellulose**, place the bag of insulation material on the hopper. Use a knife to open the bag so that the material falls into the hopper. Your FORCE/1 is designed to self-feed. **Fiberglass**, place the bag on the side of the hopper. Cut the bag in thirds and dispense one third of the contents gradually until the agitator breaks up and conditions the material. Load the remainder of the material according to the distribution rate. Empty no more than 1/3 bag at a time into the hopper, waiting until at least 1/4 of the material has been used before adding additional insulation. **Forcing insulation material will cause overloading, electrical failure or possible machine damage.**

If the agitator stops or the circuit breaker on the electrical panel trips, unplug the machine from electrical power. Remove the cause of the jam from the hopper. You may have to empty all the insulation material to locate and remove the jam. After clearing, reset the circuit breaker, reconnect power and continue normal operation. *See page 22 for more information on unjamming.*

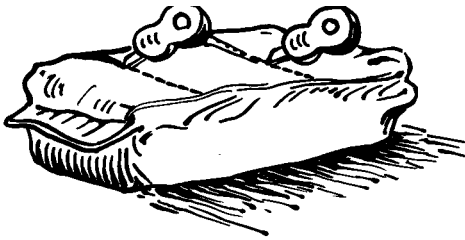

Fiberglass Insulation Only: Cut as shown and break bag into three sections

THE FORCE/1

Operational Guidelines

ATTIC OPERATION:

When blowing cellulose, use a minimum of 100 feet of 2½ inch hose. For installing fiberglass, use a minimum of 150 feet of 2½ inch hose.

Effective blowing of insulation material into an attic requires a “lofting” technique, allowing the material to be thrown in a 6-8 foot arc. Lofting will result in more even coverage and efficient use of material.

BLOWING SIDEWALLS:

When blowing sidewalls, use the following settings and recommendations as guidelines. Remember that settings may change from job to job, material to material, or nozzle to nozzle. Hose length and humidity may also affect your results.

Two hole method, standard wall construction: 2" x 4" x 16" on center.

Hole size	Slide gate opening	Air Setting
2"	6½"	100%
1"	2¼"	100%
5/8"	1½"	100%

Keeping material levels nearly constant in the hopper will improve sidewall cavity densities. Maintaining the level at approximately half full produces the most consistent results.

A gradual transition in hose size will help ensure the material flows evenly through the nozzle. At the machine, use 50 feet of 2½ inch hose. Next, connect 50 or 100 feet of 2 inch hose using the 2½ to 2 inch reducer, secured by the provided hose clamps. Attach the desired wall nozzle.

The maximum length of hose that should be used with your FORCE/1 is 200 feet.

THE FORCE/1

Operational Guidelines (Sidewalls), Cont

If clogging or less than satisfactory compaction occurs, adjust the slide gate inward by $\frac{1}{2}$ inch increments until the situation clears. If the problem doesn't clear, add an additional 50 feet of 2 inch hose and readjust your machine settings.

Insert the insulation nozzle into the lower hole of the wall cavity. Turn blower switch "on" first, then the agitator. When the sidewall is full, the FORCE/1 blower will rev up, trying to work harder and material flow may stop. Turning "off" first the agitator, then the blower keeps the material from clogging the outlet hose. Allow the blower to completely stop before removing the nozzle from the hole. Repeat the procedure using top hole until wall cavity is full.

Caution: If you are inexperienced with blowing sidewalls you may loosen or blow off sheetrock, or you may accidentally fill areas such as closets.

THE FORCE / 1
Sidewalls & Insulation Material

Construction example: 2 inches x 4 inches x 8 feet on 16 inch centers,
 2.8 cubic foot cavity

CELLULOSE COVERAGE:

1.6 pound material density, 18.7 pound bag

Wall Pack Density	Pounds Per Cavity
4.0 pounds	11.2 pounds
3.5 pounds	9.8 pounds
3.0 pounds	8.4 pounds

Average yield with Cellulose: 1.9 cavities per 18.7 pound bag

FIBERGLASS COVERAGE:

JM Product Information: (800) 654-3103
 Johns Manville Climate Pro, 25.5 pound bag

Wall Pack Density	Pounds Per Cavity
1.70 pounds	4.65 pounds

Average yield with Climate Pro: 5.8 cavities per 27 pound bag

CertainTeed Technical Services: (800) 233-8990
 CertainTeed InsulSafe SP, 31 pound bag

Wall Pack Density	Pounds Per Cavity
1.80 pounds	5.04 pounds

Average yield with InsulSafe SP: 6.15 cavities per 31 pound bag

These examples are guidelines only. Consult individual manufacturers
 for specific information.

Guardian Product Information: (800) 748-0035
 Attic Guard PLUS, 33 pound bag

Wall Pack Density	Pounds Per Cavity
2.2 pounds	6.16 pounds

Average yield with Attic Guard PLUS: 5.36 cavities per 33 pound bag

These examples are guidelines only. Consult individual manufacturers
 for specific information.

THE FORCE/1

Sidewalls & Insulation Material

FIGURING WALL CAVITY AREA

Measure wall cavity in inches. Multiply depth x width x height. Example:

(1) $3\frac{1}{2}$ " deep x $14\frac{1}{2}$ " wide x $92\frac{5}{8}$ " tall = 4,700 cubic inches

(2) Divide 4,700 by 1,728 = 2.72 cubic feet in the cavity.

Each wall cavity may vary slightly.

(1,728 equals the number of cubic inches in a cubic foot.)

Actual lumber dimensions:

2 x 4 x 8: $1\frac{1}{2}$ inches x $3\frac{1}{2}$ inches x $92\frac{5}{8}$ inches

2 x 6 x 8: $1\frac{1}{2}$ inches x $5\frac{1}{2}$ inches x $92\frac{5}{8}$ inches

THE FORCE/1

Generators and Extension Cords

Your FORCE/1 will operate on power from a commercial-sized generator. No household generators may be used due to the high inrush requirements of the FORCE/1. **Also, generators made by Honda, Yamaha, Coleman and Generac are not recommended.** While they are of high quality, these generators do not have the inrush protection devices necessary to start the FORCE/1 and protect the generator. The start-up requirement for a FORCE/1 is 3450 watts; normal operating requirement is 1725 watts. **We recommend a generator of not less than 4000 watts, 115 VAC.** In addition, Intec recommends generators that have a 50% power boost feature which aids the generator in high current startups.

Running additional equipment from the same generator means you will need to know the total electrical requirements before selecting the correct size of generator. For details on selecting and purchasing a generator, please call INTEC.

Note: Using a generator of insufficient size will void your Warranty.

Adding Additional Power Cords.

Cord Current Capacities, Type S & SVT

Wire Size AWG	3 Conductor Amps	4 Conductor Amps
10	25	20
12	20	15
14	15	12
16	10	8
18	7	6

The length of cord and ambient temperature does have an effect on the electrical current capacity. Consult Intec for your specific needs or your local electrical distributor.

THE FORCE/1

Maintenance

Reasonable preventive maintenance will help ensure your FORCE/1 gives you many years of satisfactory use. Cleaning the interior and exterior of your machine and protecting its finish with a product such as Armor All will keep it looking new.

CORDS AND SWITCHES

The remote cord and switches are subject to considerable wear and tear during normal use. Inspect all cords and switches each week for cuts or loose connections. Repair or replace any damaged components at once to avoid possible injury.

AIRLOCK BLOW BACK

Airlock seals are the most important component of keeping your FORCE/1 running in original condition. Airlock seals function much like the rings in a car engine, keeping pressure and air from escaping. When a seal or plate is damaged, air from the blower will escape back into the hopper causing "blow back." Blow back will result in a considerable decrease in production.

Checking for blow back; unplug the machine from electrical power and empty all insulation material from the hopper. Block the hose outlet with duct tape, or use the palm of your hand. Reconnect the power and turn on both the blower and agitator motor. A hissing or puffing sound of air escaping into the hopper indicates blow back. In addition, any insulation material remaining in the airlock will blow back into the hopper, creating dust. To remedy blow back, it is necessary to replace the airlock seals or plates. Note: Your FORCE/1 comes from the factory preset to produce 2.5-3.0 PSI. You may purchase a pressure gauge from Intec to aid in determining the pressure developed by the blower and airlock, system.

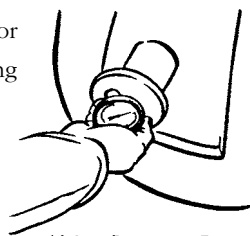

Using Pressure Gauge

THE FORCE/1

Maintenance, Cont.

REPLACING AIRLOCK SEALS

Unplug the FORCE/1 from electrical power and empty all insulation material from the hopper. Seal replacement requires a 7/16" socket and ratchet, a 6" socket extension and a 7/16" open-end wrench. With the machine in an upright position, locate the four 1/4"20 bolts holding the seal in place. Loosen and remove the fasteners. Remove the damaged seal from the front rotor plate which remains attached to the shaft. Reverse the process to install a new seal. Be careful that the direction of the seal is correct. When it is equally wrapped around both sides and seated all the way down on the rotor shaft, reinstall the back rotor plate and fasteners. Snug down the bolts. **Do not overtighten.** Overtightening will cause the seal to bow out at the ends producing uneven wear and premature failure. To replace other damaged seals, reconnect to electrical power and, using the remote switch, move the airlock seal into the position for removal. Again, disconnect from electrical power before doing the actual repair or replacement. **Note:** Take care not to install the seals backwards.

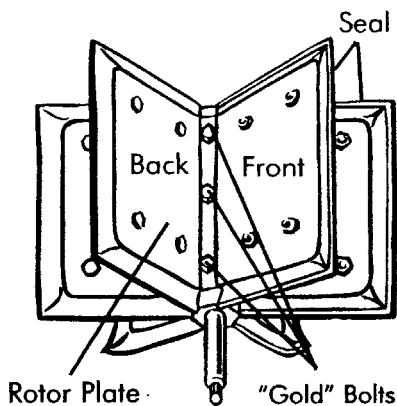

THE FORCE/1

Maintenance, Cont.

AIRLOCK ROTOR ROTATION: Gearbox P/N 12007 rotates the airlock CCW (Counter Clockwise) See figure 1.

Figure 1
Mfg from 7/97- 12/02

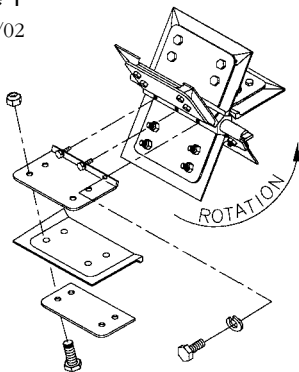

Gearbox P/N 12008 rotates the airlock CW (Clockwise) See figure 2.

Figure 2
Mfg from 12/02- Present

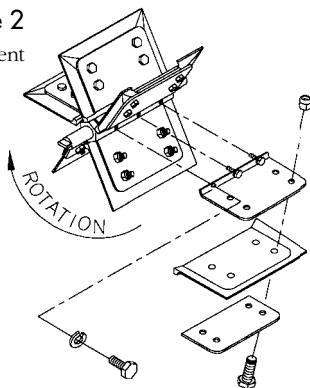

REPLACING ROTOR PLATE

The rotor plates are designed to “give” if a foreign object comes in contact with the airlock chamber, but they can be bent. Before replacement, disconnect the machine from electrical power and remove all insulation from the hopper. Check for proper rotation of airlock rotor.

For further information on gearbox, see page 24

THE FORCE/1 *Maintenance, Cont.*

Determining which plate or plates to replace is easy. The distance between each plate should measure approximately $5\frac{1}{4}$ inches. Measure the distance for all plates. If any or all rotor plates do not measure approximately $5\frac{1}{4}$ inches, replace the bent plate(s).

Plate replacement requires a $\frac{7}{16}$ " socket and ratchet, a 6" socket extension and a $\frac{7}{16}$ " open-end wrench. With the machine in an upright position, locate the four $\frac{1}{4}$ "x20 bolts that secure the seal. Loosen and remove the fasteners and the seal from the front rotor plate. Locate the "gold" bolts that attach the rotor plate to the airlock shaft.

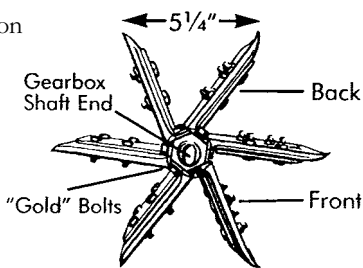

Rotor Plate

See illustration. Remove fasteners and bent rotor plate(s) from shaft. Reverse the procedure to install a new rotor plate. If you break a "gold" bolt during this process, do not use any other type of bolt to reattach the rotor plate to the airlock shaft. Contact your distributor or the factory for a replacement "gold" bolt.

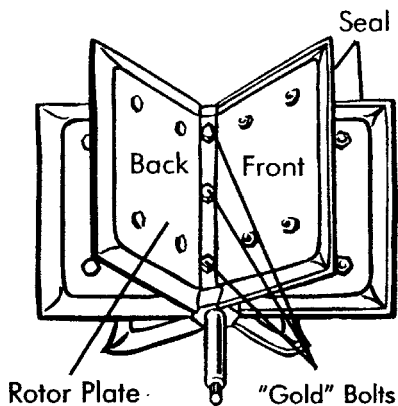

THE FORCE/1

Maintenance, Cont.

GEARBOX (Mfg 1/92 - 7/97)

The oil in the gearbox of your FORCE/1 should be changed every year to ensure proper lubrication of the gears and seals.

Changing the oil in models manufactured before

July, 1997: Place the machine on its side with clear access to the two drain/fill plugs on the gearbox. Place a drain pan under each plug to catch the used oil. Remove the drain plug from each of the two gearbox chambers with a 90° 3/8 inch hex wrench. Drain the oil into the pans. To refill, pour four ounces of oil into a six ounce disposable paper cup. Bend cup lip to form a pouring spout. Pour a total of 12 ounces into each chamber and reinstall plugs

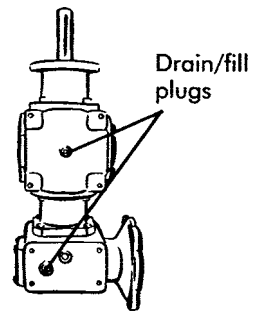

Model 12005

using the hex wrench. **Note:** at cold temperatures, oil thickens, slowing the draining process. Leave your machine in a warm area overnight (eight hours) to make oil changing easier. See illustration for the location of the drain/fill plugs. Models manufactured before July, 1997 require 24 ounces of oil, 12 in each chamber.

Model 12007 (Mfg. from 7/97 - 12/02)

Place the machine on its side with clear access to the single drain/fill plug on the gearbox. Place a drain pan under the plug to catch the used oil. Remove the drain plug from the gearbox with a 90° 3/8 inch hex wrench. Drain the oil into the pan. To refill, pour four ounces of oil into a six ounce disposable paper cup. Bend cup lip to form a pouring spout. Pour a total of 20 ounces into the chamber and reinstall plug using the hex wrench.

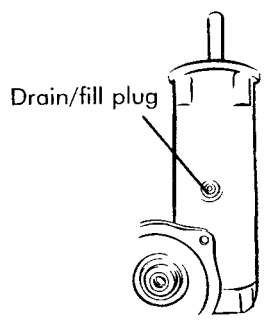

Model 12007

Note: at cold temperatures, oil thickens, slowing the draining process. Leave your machine in a warm area overnight (eight hours) to make oil changing easier. See illustration for the location of single drain/fill plug. Models manufactured after July, 1997 require 20 ounces of oil.

THE FORCE/1

Maintenance, Cont.

The gearbox and the airlock should be perpendicular to each other. Proper alignment helps prevent premature wear on the gearbox/airlock shaft connection.

Recommended gearbox oil:

Model 12007

Temperature 40° - 100° F Mobil SHC 634 gear lube

Temperatures -20° - +40° F Mobil 1 synthetic 5W-30

Worm gear case capacity 20 oz.

Model 12008 (Mfg. from 12/02 - present)

Lay machine on its side with clear access to the bottom drain plug. Place drain pan under drain plug and remove using a 5/16 hex wrench. Drain oil into pan, tip machine upright to drain remainder of oil in gearbox housing, close vent plug. Pour 48 ounces into worm gear case and re-install drain plug. Tip machine on side and open vent plug 1/4- 1/2 turn by hand. **Note:** In cold temperatures the oil thickens slowing the draining process. Leave the machine in a warm area overnight (eight hours) to make oil changing easier. See illustration for location of vent and drain plugs (page 22).

Recommended gearbox oil:

Model 12008

Capacity: 44 oz.

Temperature 40° - 100° F Mobil SHC 634 gear lube

Temperatures -20° - +40° F Mobil 1 synthetic 5W-30

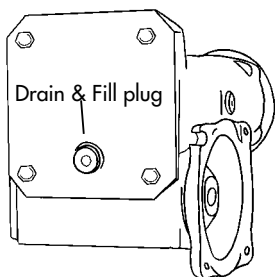

Model 12008

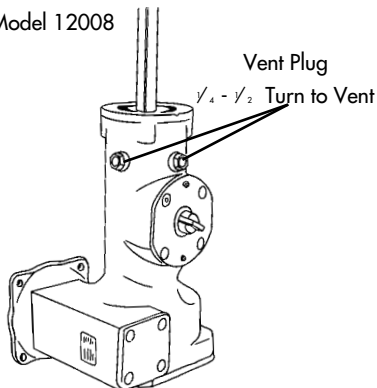

THE FORCE/1

Maintenance, Cont.

Gearbox/Agitator/Airlock Unjamming procedure: Empty hopper, disconnect all electrical cords to machine. Tip machine upside down onto hopper, locate and remove fan cover on agitator motor. **Note:** Depending upon the motor used it will be necessary to remove the screws holding the fan cover on before removal, otherwise all other covers may be pried off using screwdriver. By hand, carefully turn fan blade in the direction of the arrow as indicated on label until jam is cleared. **Note:** It will take approximately 15 turns of the fan blade before you start to reverse the entire airlock system. **Caution! Fan blade may break if excessive force is used.**

Note: The gearbox and the airlock must be perpendicular to each other. Proper alignment prevents premature wear on the gearbox and airlock shaft connection.



Removing Cover



Rotation Label

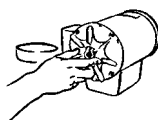

Turn by hand

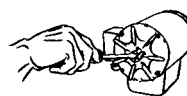

Using Screw Driver

THE FORCE/1
Maintenance, Cont.

BLOWER MAINTENANCE

Keeping the blower as clean as possible will avoid system overheating. Overheating will cause lowered production, possible system failure and shorten the expected life of your FORCE/1. Inspect blower brushes every three months or 100 hours of use. Replace brushes when they reach ¼ inch or less in length. Change the brushes before the brush stunt touches the commutator. When reassembling, the lead wires must be isolated from the motor frame and any rotating parts.

CLEANING

Use compressed air to blow out motor and intake of blower every 20-30 hours of use to maximize blower impeller and motor life.

Blower Warranty Considerations. The following blower abuse is not covered by warranty:

Damage in shipment

Visible moisture damage such as rust

Rust or other corrosion on motor exterior

Dirty motor or dust buildup in impeller

Broken components, i.e. brushes, brush holder, etc.

User modification of blower, holes, etc.

User rewind armatures or fields

Evidence of user disassembly

Evidence of foreign object in fan end of motor

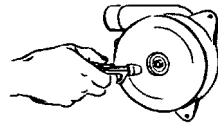

THE FORCE/1

Troubleshooting

Problem	Likely Cause	Remedy
Agitator does not operate.	Power cord not plugged in.	Check cord and plug in.
Note: Agitator can not be turned by hand.	Loose power cord/extension cord at electrical connection.	Check condition of electrical plug blades.
	Toggle switch for agitator is not in "on" position.	Flip toggle switch "on" at main panel.
	Circuit breaker tripped on main panel.	Push to reset tripped circuit breaker.
	Jam in airlock exit tube.	Disconnect electrical power. Remove hose from the exit tube. Locate jam and remove material with pliers.
	Jam between blade of agitator and airlock.	Disconnect electrical power. Remove insulation material from hopper. Locate jam and remove material with pliers.
	Bearing on top of gearbox worn or frozen (Bearing guides the agitator shaft).	Have bearing replaced by a qualified technician.
	Start-up capacitor blown on agitator motor.	Have capacitor replaced by a qualified technician.
	Remote rocker switch for agitator motor has failed.	Replace with original factory part.
	Main panel toggle switch for agitator motor has failed.	Replace with original factory part or with a rated 20 amp @ 110V toggle switch.
Loose wire in electrical system.	Have the system inspected by a qualified technician.	

THE FORCE/1
Troubleshooting, Cont.

Problem	Likely Cause	Remedy
Machine makes a ratcheting noise when turned on.	Gearbox drive not engaged with airlock rotor connection.	Loosen gearbox and gearbox stabilizers. Align gearbox and airlock perpendicular to each other.
	Low oil level in gearbox.	Have the gearbox inspected and repaired by a qualified technician if necessary.
Decreased material throw.	Worn airlock seals.	Inspect seals for tears or cuts. See maintenance section to replace or adjust as necessary.
	Kink in hose.	Run hose as straight as possible to help maintain production.
	Excess air leaking into hopper.	Inspect seals for tears or cuts. See maintenance section to replace or adjust as necessary.
Machine does not run	No power.	Check source of electrical power. Possible tripped circuit breaker.
	Main panel circuit breaker tripped.	Push to reset.

THE FORCE/1

Troubleshooting Cont.

Problem	Likely Cause	Remedy
Air, but no material, comes out of hose	Slide gate closed.	Open to operating position.
	Bridging (air pocket in hopper).	Turn machine "off" and disconnect from electrical power. Redistribute material in hopper. Reconnect to electrical power.
	Remote rocker switch for agitator motor has failed.	Replace with original factory part.
	Circuit breaker tripped on main panel.	Push to reset.
	Jam between blade of agitator and airlock.	Disconnect electrical power. Remove insulation material from hopper. Locate jam and remove material with pliers.
Blower does not operate.	Blower toggle switch on main panel is "off".	Switch toggle to "on", use remote box to operate.
	Remote rocker switch for blower motor has failed.	Replace with original factory part.
	Loose power cord/extension cord at electrical system.	Check condition of electrical plug blades.
	Loose wire in electrical system.	Have the system inspected and repaired by a qualified technician.
	Worn brushes in blower motor	Have the brushes inspected and replaced by a qualified technician.

THE FORCE / 1
Troubleshooting Cont.

Problem	Likely Cause	Remedy
Agitator trips circuit at main panel.	Low voltage. 99-104 VAC	FORCE/1 requires a minimum of 20 amps @ 115V. Relocate power cord to a dedicated 20 amp circuit.
	Incorrect size extension cord.	For an additional 50' run, use 12/3 cord. For a 100' run use 10/3 cord.
	Pushing down on material in hopper.	Do not push down on insulation while filling hopper.
	Wet insulation material in hopper.	Do not use wet material. Disconnect electrical power and remove wet material.
	Worn or frozen airlock bearing.	Have bearing checked and replaced by a qualified technician.
Blower trips circuit breaker at power source.	Low voltage.	Blower requires a minimum of 20 amps @ 115V. Use a dedicated refrigerator outlet or equivalent.
	Incorrect extension cord.	For an additional 50' run, use 12/3 cord. For a 100' run use 10/3 cord.
	Worn brushes in blower motor.	Inspect blower brushes, Brushes should not be shorter than 3/8" overall length. Replace Brushes if they are less than 3/8" or chipped.
Operator in attic keeps getting shocked.	Static electricity from insulation.	Mix half-and-half solution of water and fabric softener. Mist into insulation while loading hopper. Note: excess moisture will cause jamming.

Note: To clear all jams, turn machine upside down and follow the instructions printed on the motor housing.

THE FORCE/1

Mechanical Drawings

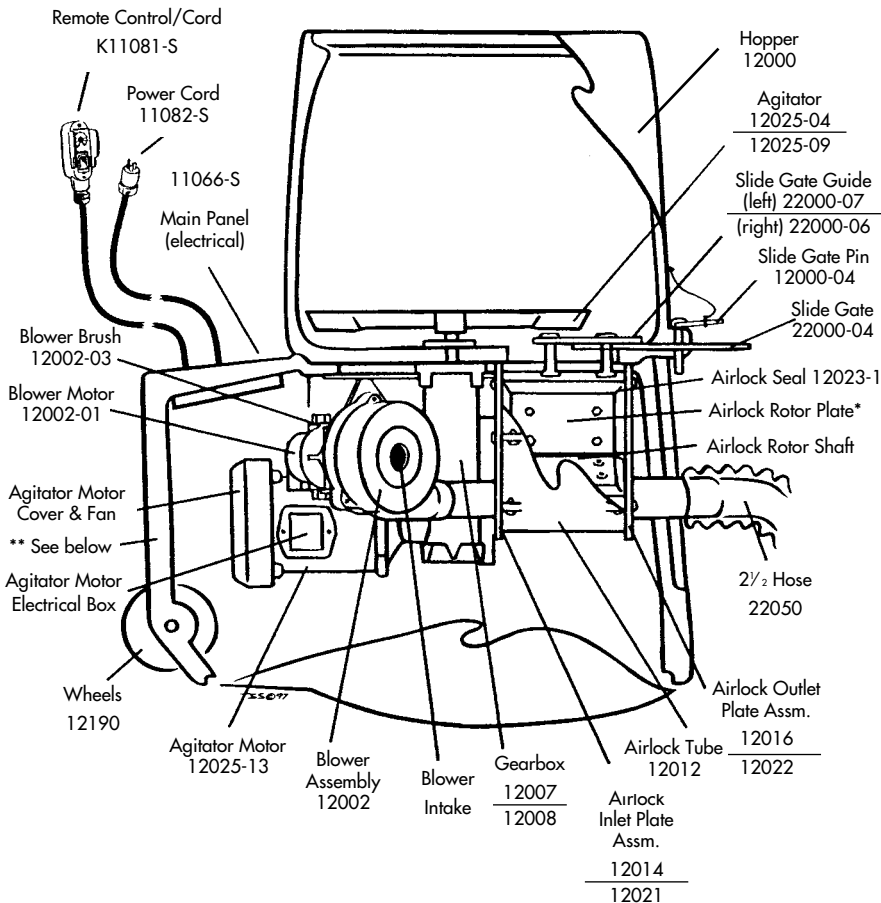

**
For machine mfg 7/97-12/02 order P/N 12001
For machine mfg 12/02 order P/N 12001-01

* Airlock Rotor Plates
(left) 12022-00
(right) 12022-01
(center) 12022-02
(back) 12022-03

Manufactured from 9/03 - Present

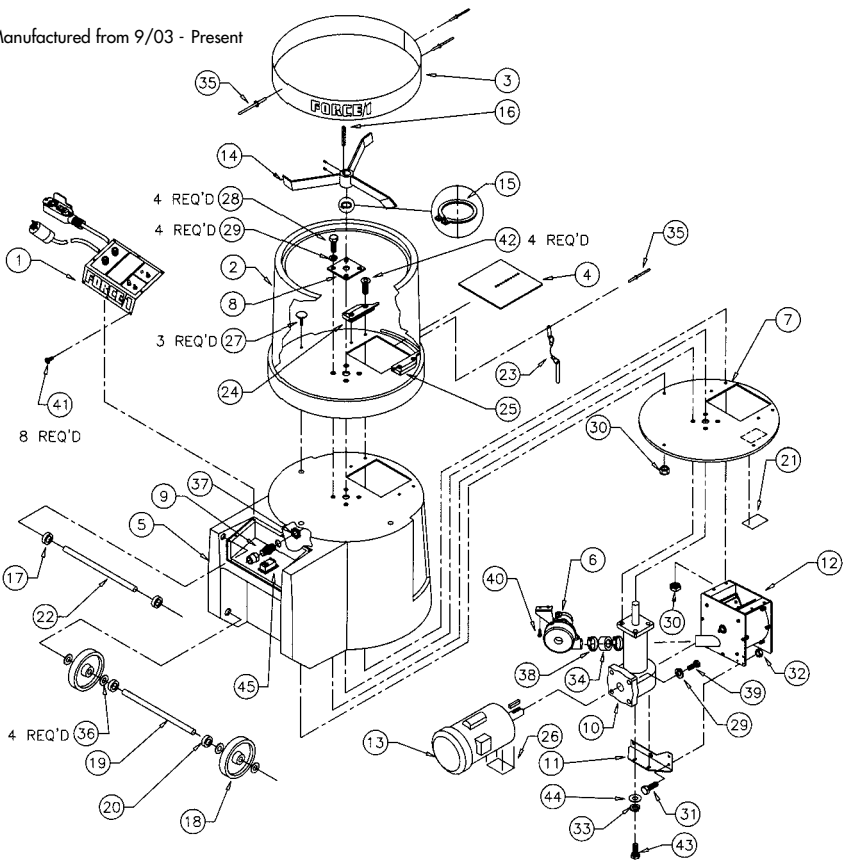

- | | |
|---|--|
| 111009-S ..ELECTRICAL PANEL ASSEMBLY
W/REMOTE & PC | 2422000-06 SLIDE GATE GUIDE, RIGHT |
| 212000HOPPER STD, BLUE | 2522000-07 SLIDE GATE GUIDE, LEFT |
| 312000-02 HOPPER BELLY BAND, STD | 2622022BLOWER MOUNT BRACKET |
| 412000-04 SLIDE GATE, STD F/1 | 2722025-05 AGITATOR MOTOR ROTATION LABEL |
| 512001BASE STD, BLACK | 28F1033/8" x 16 x 1-1/2" GRD 2 ELEV. BOLT |
| 612002-01 BLOWER 115 V, 60 HTZ, 104 CFM | 29F1043/8" x 16 x 1-3/4" GRD 5 HEX ZN |
| 712004BASE PLATE, 3/16 x 21 | 30F1073/8" SPLIT LOCK WASHER ZN |
| 812005-15 GEARBOX SUPP. PLATE 4" x 4" x 3/4" | 31F1093/8" x 16 NYLON LOCK NUT ZN |
| 912006STRAIN RELIEF, PLASTIC, 1/2" | 32F1121/4" x 20 x 7/8" GRD 5 HEX ZN |
| 1012008GEARBOX F/1, 2002 | 33F1141/4" x 20 NYLON LOCK NUT ZN |
| 1112007-17 GEARBOX STABILIZER, F/1 | 34F199M8 SPLIT LOCK WASHER ZN |
| 1212013-S ..AIRLOCK ASSEMBLY, STD | 35F1293/32" x 11/32 ALU M. RIVET |
| 1312025-S ..AGITATOR MOTOR 3/4 HP,
115 V, 60 HTZ, GE, ASSM. | 36F1303/16" x 11/16" ALUM. RIVET |
| 1412025-09 AGITATOR STD W/SET SCREWS | 37F1315/8" FLAT WASHER ZN |
| 1512025-05 GEARBOX AGITATOR SHAFT SNAP RING | 38F132STRAIN RELIEF LOCK NUT, 1/2" |
| 1612025-06 KEY 3/16" x 2" | 3922049-05..HOSE CLAMP, 2" |
| 1712041HANDLE CLAMP, 3/4" | 40F1433/8" x 16 x 1" HH GIRD 5 ZN |
| 1812190WHEEL, 5/8" X 6" | 41F1521/4" x 20 x 1/2" GRD 2 ROLOCK ZN |
| 1912190-01 WHEEL AXLE 5/8" X 15-1/2" | 42F1591/4" SAE FLAT WASHER |
| 2012190-02 WHEEL SET COLLAR 5/8" | 43F224#10 x 32 x 3/8" PHIL TRUSS S/S |
| 2112270SERIAL TAG F/1 | 44F3323/8" x 16 x 2" SOCKET FLAT CAP SCREW ZN |
| 2212274HANDLE, SS, 3/4" x 14" | 45F198M8-1.25x25 HEX C/S METR., ZN |
| 2322000-04 SLIDE GATE CABLE & PIN | 46F363#14 FLAT WASHER, ZN |
| | 4711024RELAY, 115 VAC |
| | 4822026BLOWER REDUCING RING |

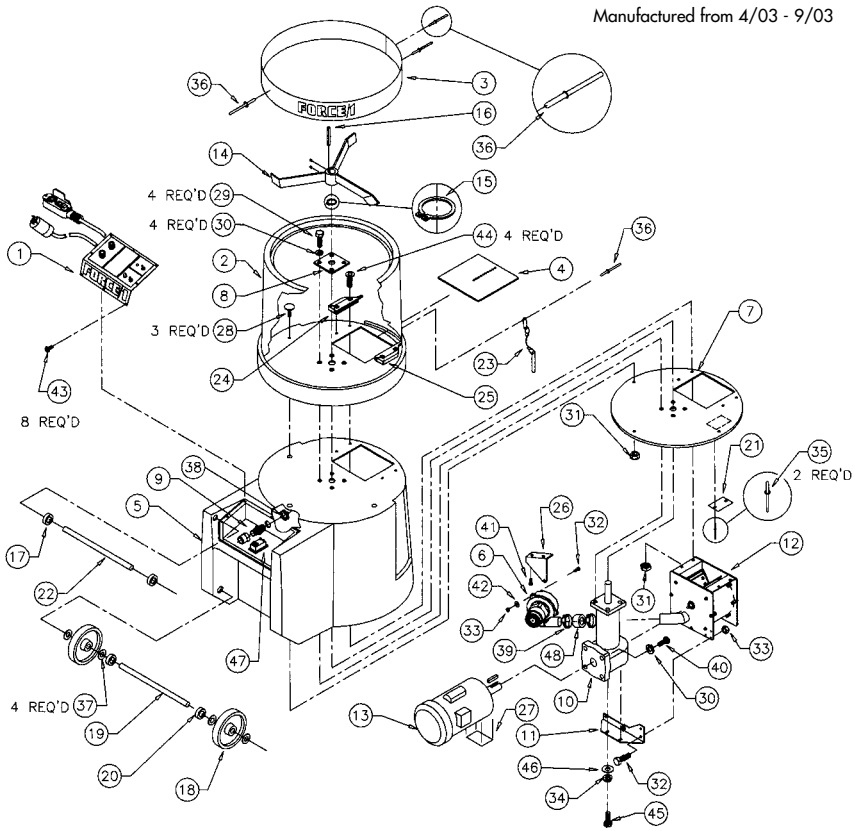

- 1.....11009-SELECTRICAL PANEL ASSEMBLY
W/REMOTE & PC
- 2.....12000HOPPER STD, BLUE
- 3.....12000-02HOPPER BELLY BAND, STD
- 4.....12000-04SLIDE GATE, STD F/1
- 5.....12001-0BASE STD, BLACK
- 6.....12002BLOWER 115 V, 60 HTZ, 104 CFM
- 7.....R2026BASE PLATE, 3/16" x 21"
- 8.....12005-15GEARBOX SUPP. PLATE 4" x 4" x 3/4"
- 9.....12006STRAIN RELIEF, PLASTIC, 1/2"
- 10.....12008GEARBOX F/1, 2002
- 11.....12007-17GEARBOX STABILIZER, F/1
- 12.....12013-SAIRLOCK ASSEMBLY, STD
- 13.....12025-SAGITATOR MOTOR 3/4 HP, 115 V,
60 HTZ, GE, ASSM.
- 14....12025-09AGITATOR STD W/SET SCREWS
- 15....12025-05GEARBOX AGITATOR SHAFT
SNAP RING
- 16....12025-06KEY 3/16" x 2"
- 17....12041HANDLE CLAMP, 3/4"
- 18....12090WHEEL, 5/8" X 6"
- 19....12190-01WHEEL AXLE 5/8" X 15-1/2"
- 20....12190-02WHEEL SET COLLAR 5/8"
- 21....12270SERIAL TAG F/1
- 22....12274HANDLE, SS, 3/4" x 14"
- 23....22000-04SLIDE GATE CABLE & PIN

- 24....22000-06SLIDE GATE GUIDE, RIGHT
- 25....22000-07SLIDE GATE GUIDE, LEFT
- 26....22022BLOWER MOUNT BRACKET
- 27....22025-05AGITATOR MOTOR ROTATION LABEL
- 28...F103.....3/8" * 16 x 1-1/2" ELEV. BOLT
- 29...F104.....3/8" * 16 x 1-3/4" HEX ZN
- 30...F107.....3/8" SPLIT LOCK WASHER ZN
- 31...F109.....3/8" * 16 NYLON LOCK NUT ZN
- 32...F112.....1/4" * 20 x 7/8" HEX ZN
- 33...F114.....1/4" * 20 NYLON LOCK NUT ZN
- 34...F199.....M8 SPLIT LOCK WASHER ZN
- 35...F129.....3/32" x 11/32" ALUM. RIVET
- 36...F130.....3/16" x 11/16" ALUM. RIVET
- 37...F131.....5/8" FLAT WASHER ZN
- 38...F132.....STRAIN RELIEF LOCK NUT, 1/2"
- 39...F142.....8 * 32 x 1/2" SELF TAPPING SCREW
- 40...F143.....3/8" * 16 x 1" HH ZN
- 41...F152.....1/4" * 20 x 1/2" ROLOCK ZN
- 42...F159.....1/4" SAE FLAT WASHER
- 43...F224.....10 * 32 x 3/8" PHIL TRUSS S/S
- 44...F332.....3/8" * 16 x 2" SOCKET FLAT
CAP SCREW ZN
- 45...F198.....M8 x 1.25mm bolt
- 46...F363.....#14 FLAT WASHER, ZN
- 47....11024Relay, 115V

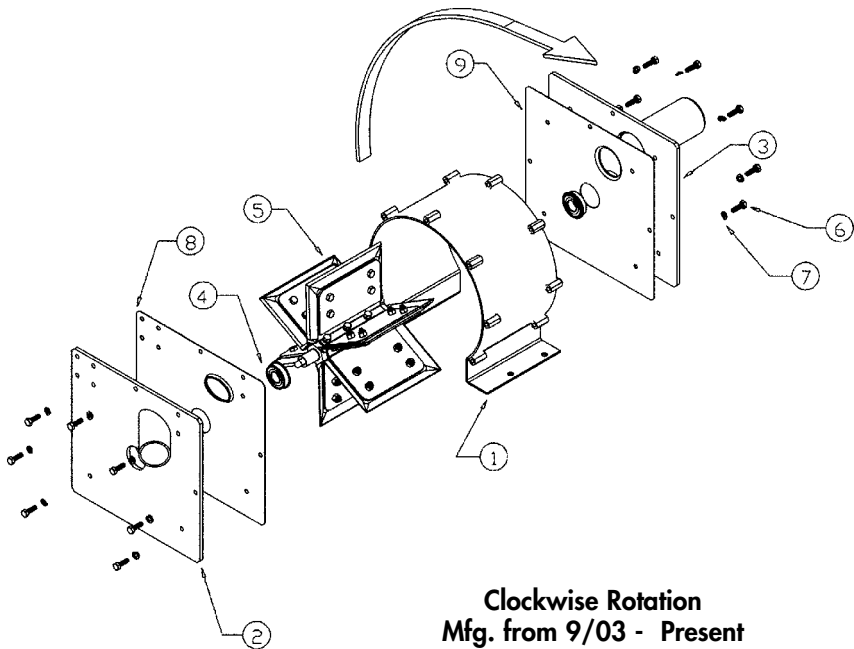

Clockwise Rotation
Mfg. from 9/03 - Present

Airlock assembly W/SS inserts
P/N 12026-01-S

Item #	PART NUMBER	DESCRIPTION
1	12012	AIRLOCK TUBE 10"
2	12011	AIRLOCK INLET PLATE ASSM. 2"
3	12022	AIRLOCK OUTLET PLATE ASSM. 2-1/2"
4	12018	AIRLOCK BEARING, END PLATE
5	12019-S	AIRLOCK ROTOR ASSM. W/SEALS
6	F112	1/4*20 x 7/8 HEX, ZN.
7	F115	1/4 SPLIT LOCK WASHER, ZN.
8	12024	AIRLOCK SS INSERT, 2"
9	12023-0	AIRLOCK SS INSERT, 2-1/2"

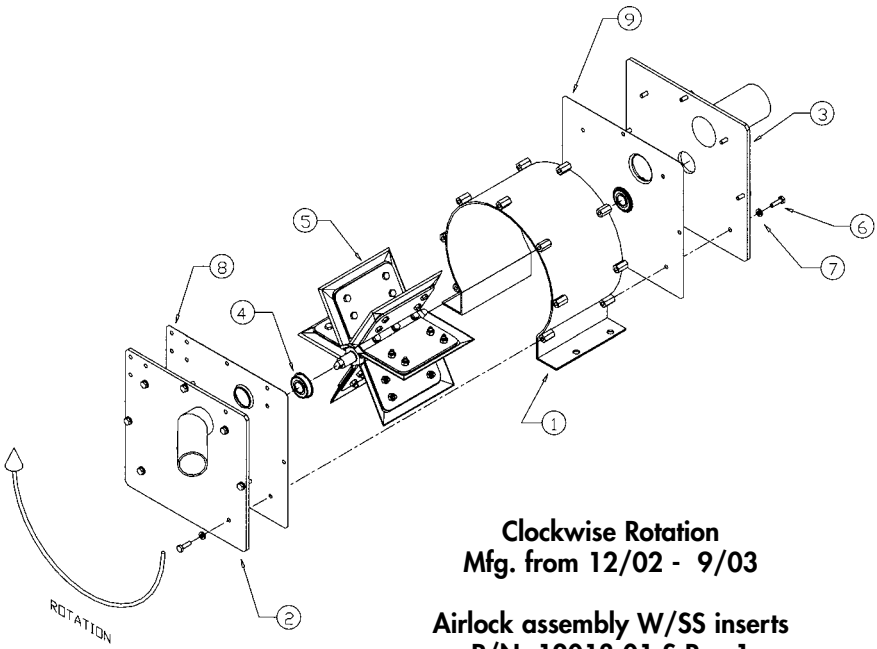

Clockwise Rotation
Mfg. from 12/02 - 9/03

Airlock assembly W/SS inserts
P/N 12013-01-S Rev 1

Item #	PART NUMBER	DESCRIPTION
1	12012	AIRLOCK TUBE 10"
2	12021	AIRLOCK INLET PLATE ASSM. 2"
3	12022	AIRLOCK OUTLET PLATE ASSM. 2-1/2"
4	12018	AIRLOCK BEARING, END PLATE
5	12020-01-S	AIRLOCK ROTOR ASSM. W/SEALS
6	F112	1/4*20 x 7/8 HEX, ZN.
7	F115	1/4 SPLIT LOCK WASHER, ZN.
8	12023	AIRLOCK SS INSERT, 2"
9	12023-0	AIRLOCK SS INSERT, 2-1/2"

Mfg from 9/03 - Present

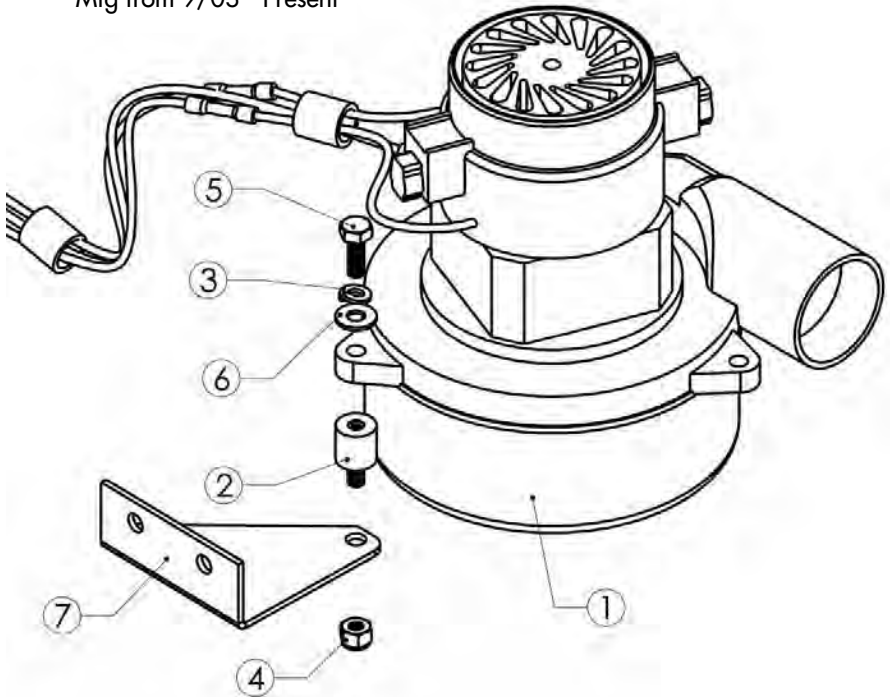

Item #	PART NUMBER	DESCRIPTION
1	12002-01	BLOWER 115V 104 CFM
2	12101	BLOWER ISOLATION MOUNT
3	F115	1/4" SPLIT LOCK WASHER
4	F114	1/4*20 NYLON LOCK NUT
5	F342	1/4*20 X 3/4" BOLT
6	F159	1/4" FLAT WASHER
7	22022	BLOWER MOUNT BRACKET

Remote Box Assembly

Mfg from 7/97- Present

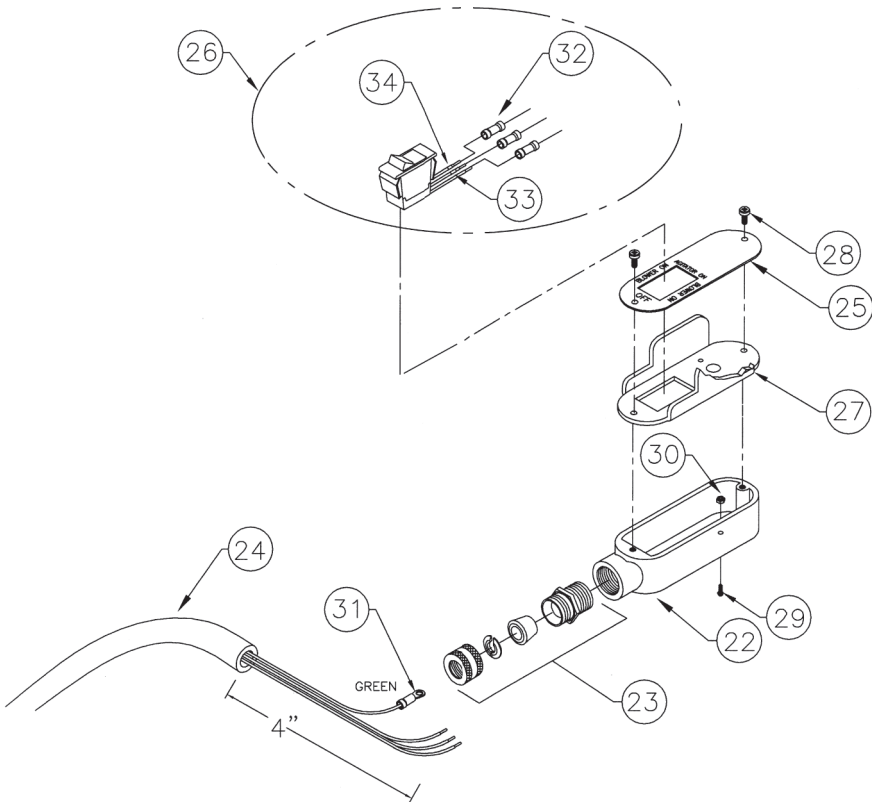

Item # PART NUMBER DESCRIPTION

2221008-0REMOTE BOX 3/4" W/HOLE
2321008-09STRAIN RELIEF, ALUM. 3/4"
2411081REMOTE CORD 16/4 x 100' (ONLY)
2501009REMOTE BOX SHIELD STICKER
2611008-06-01-S	..REMOTE BOX ROCKER SWITCH ASSM.
27RR21004REMOTE BOX 3/4" SHIELD W/O STICKER
28F1198-32 x 3/8 PP ZN
29F1226-32 x 3/8 PP ZN
30F1246-32 NYLON INSERT LOCK NUT
31F153#6 RING TERMINAL, BLUE
32F136BUTT SPLICE, BLUE
33F230SHRINK TUBE 3/16 x 1/4", WHITE
34F231SHRINK TUBE 3/16 x 1/4", RED

Mfg from 7/97- Present

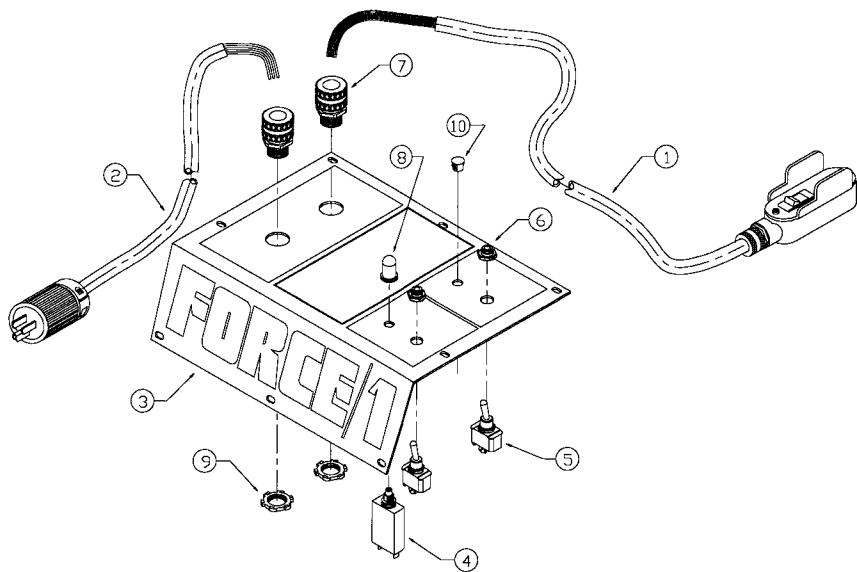

Item #	PART NUMBER	DESCRIPTION
1	K11081-S	REMOTE CORD ASSM.
2	11082-S	POWER CORD ASSM. 14/3 x 50'
3	11065	ELEC. FACE PLATE W/SILK SCR.
4	11067	CIRCUIT BREAKER 15 AMP.
5	11071	TOGGLE SWITCH 20 AMP.
6	11072	TOGGLE SWITCH SEAL
7	21008-02	STRAIN RELIEF, ALUM, 1/2"
8	21045-02	CIRCUIT BREAKER BUTTON SEAL
9	F132	STRAIN RELIEF LOCK NUT 1/2"
10	11080-01	REMOTE BOX 3/4" SHIELD PLUG

Electrical Wiring Diagram
 Electrical With Relay
 Mfg. from 10/02 - Present

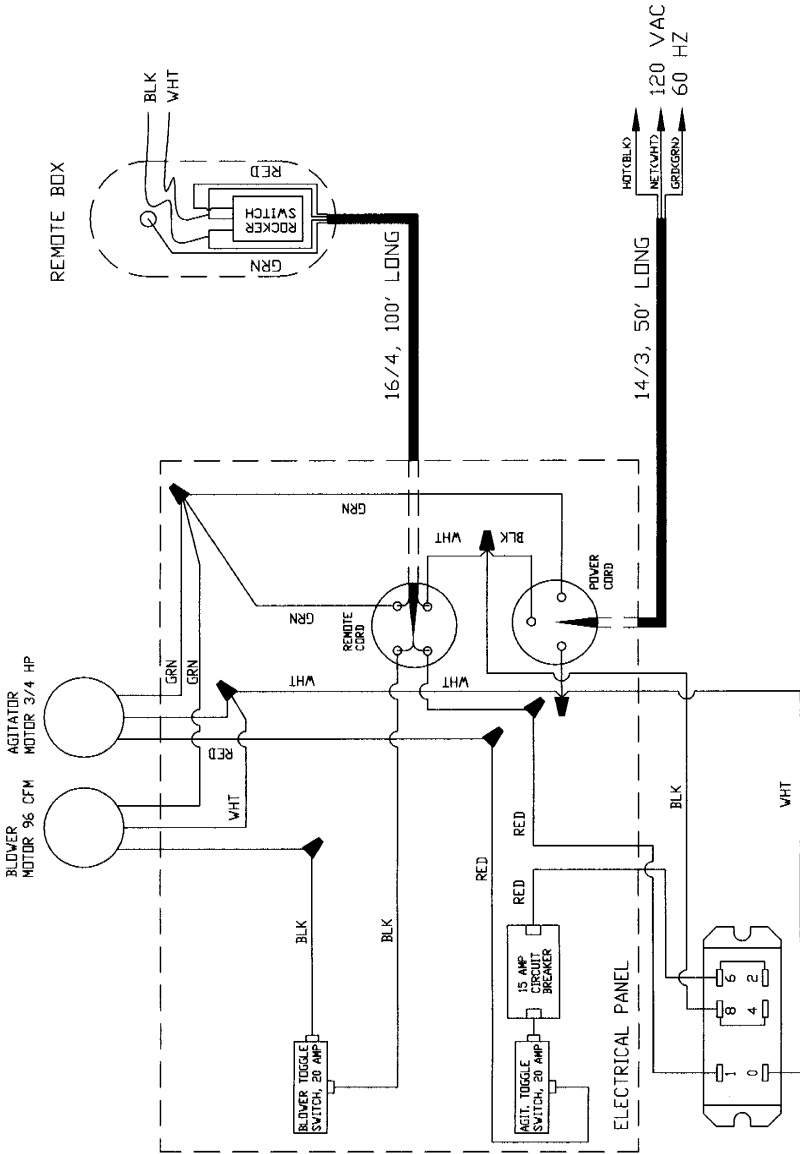

RELAY T99P7A22-120
 (MOUNTED TO THE BASE
 UNDER ELECTRICAL PANEL)

Optional Electrical

Mfg from 7/02 - Present

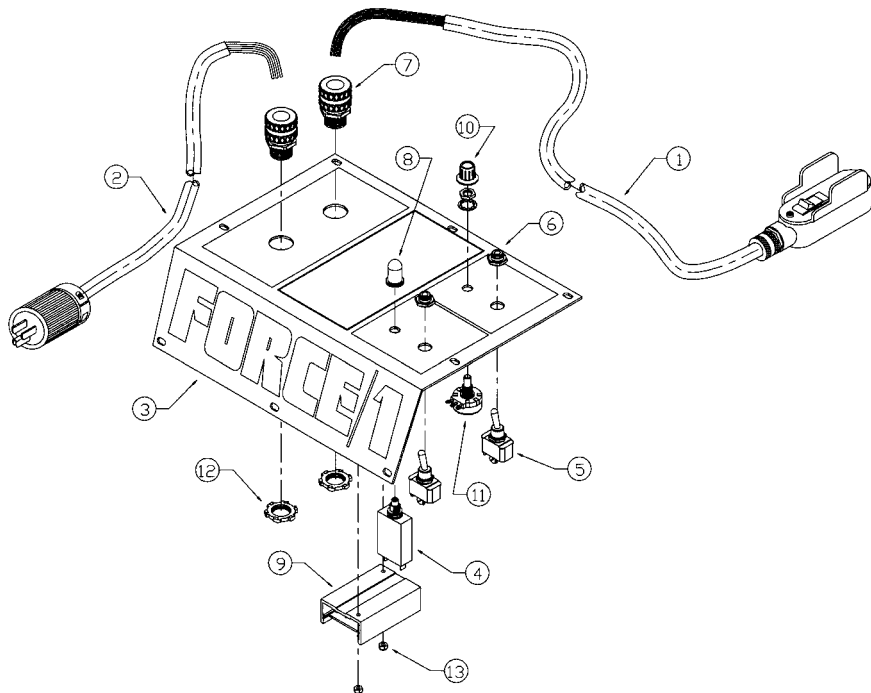

Item #	PART NUMBER	DESCRIPTION
1	K11081-S	REMOTE CORD ASSM.
2	11082-S	POWER CORD ASSM. 14/3x50'
3	11065	ELEC. FACE PLATE W/SILK SCR.
4	11067	CIRCUIT BREAKER 15 AMP.
5	11071	TOGGLE SWITCH 20 AMP.
6	11072	TOGGLE SWITCH SEAL
7	21008-02	STRAIN RELIEF, ALUM, 1/2"
8	21045-02	CIRCUIT BREAKER BUTTON SEAL
9	31044	KBGE, 25 AMP, 120 VAC
10	21143-01	VARIABLE SPEED KNOB
11	31042	VARIABLE SPEED POTENTIOMETER
12	F132	STRAIN RELIEF LOCK NUT 1/2"
13	F127	#4*40 LOCK NUT

FORCE/1

Electrical Drawings (Cont'd)

Electrical Wiring Diagram
Mfg. from 1/2011 - Present

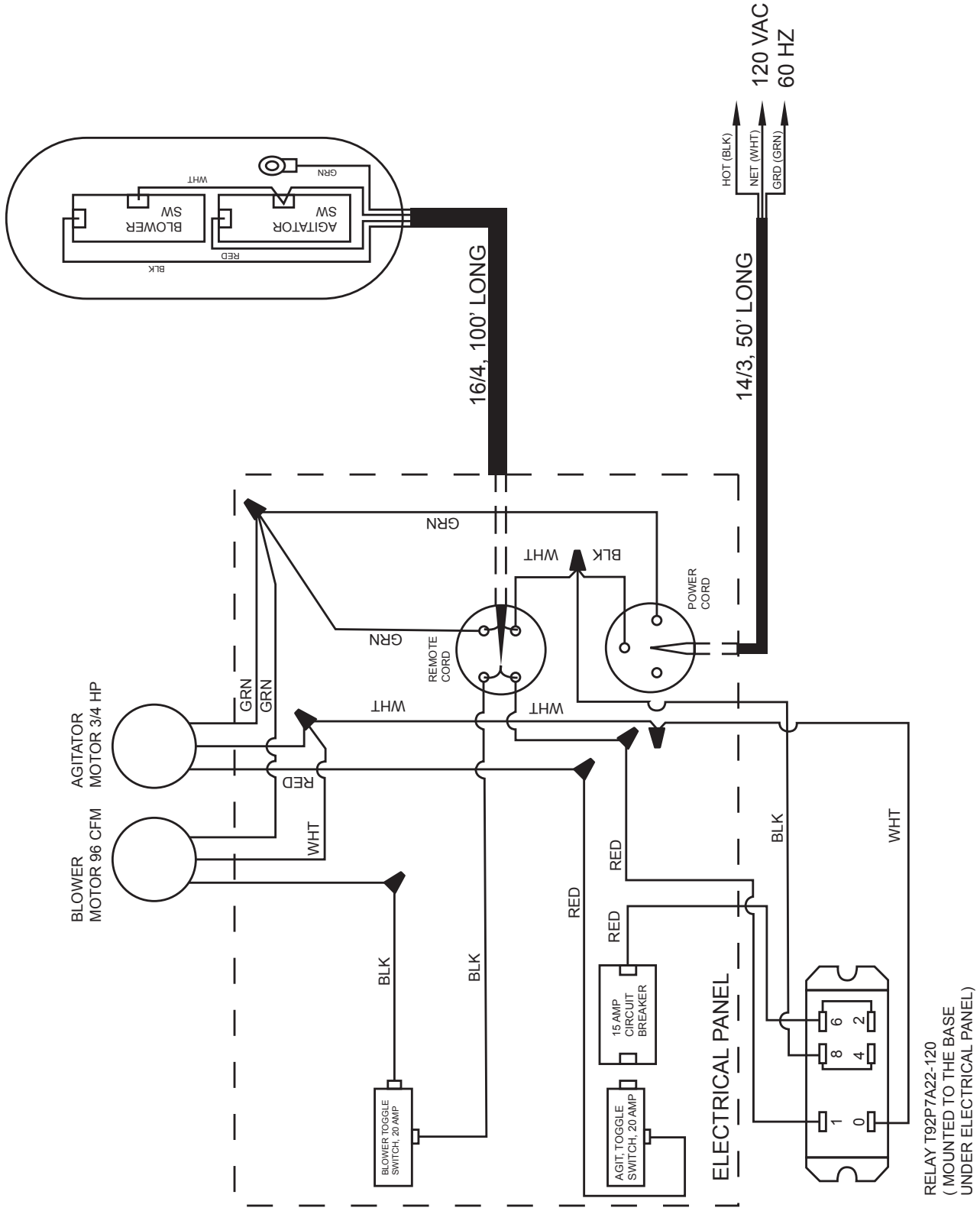

FORCE/1

Electrical Drawings (Cont'd)

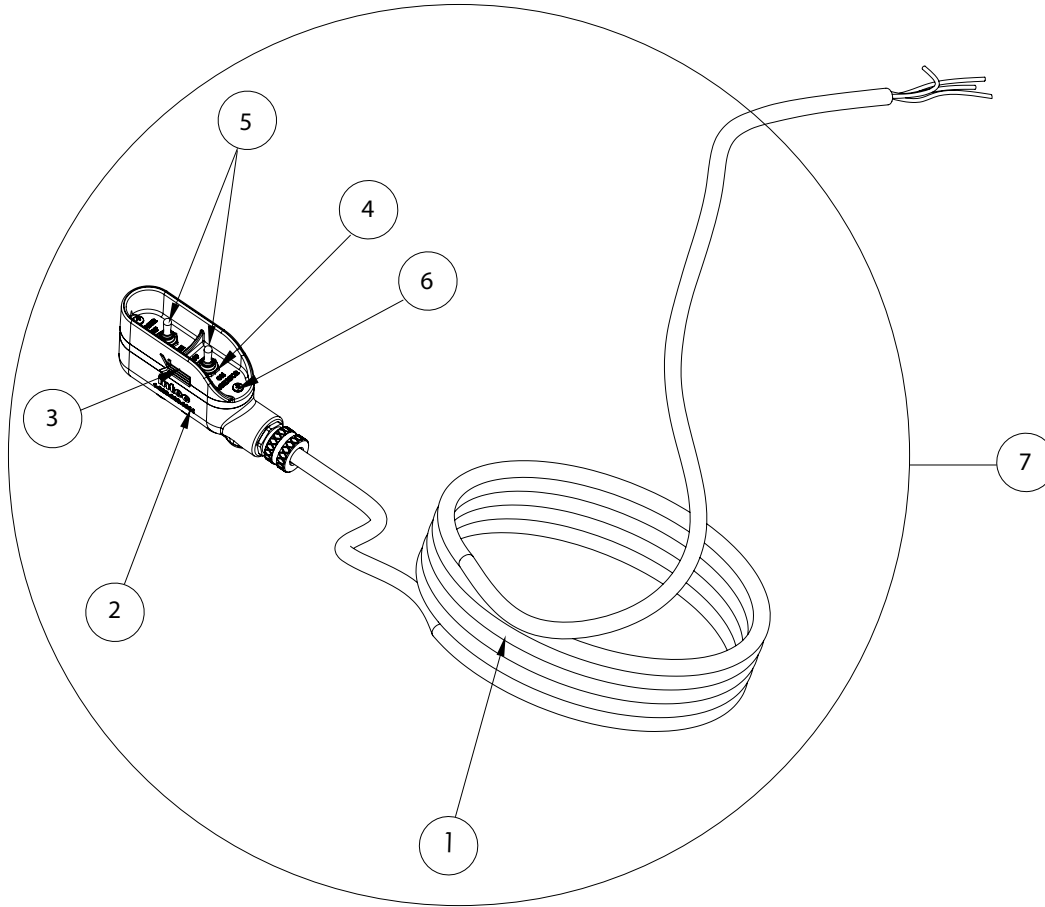

Item #	QTY.	PART NUMBER	DESCRIPTION
1.....	1.....	11081.....	Remote Cord 16/4 x 100'
2.....	1.....	21050.....	Remote Box, 3/4", Molded
3.....	1.....	21051.....	Remote, Box Shield, 3/4" Molded
4.....	2.....	11072.....	Remote Box Toggle Switch Seal
5.....	1.....	21061.....	Switch Assm, Field Replacement Remote Box Molded
6.....	2.....	F119.....	8*32 x 3/8" Screw
7.....	1.....	K11082-S.....	Remote Cord Assm Molded, 16/4 x 100'

BEFORE OPERATING EQUIPMENT

Remote control operation:
When starting the machine, **FIRST, TURN ON THE BLOWER** then the agitator. When shutting the machine off, **FIRST, TURN OFF THE AGITATOR** then the blower.

NOTE: Do not allow the agitator to run for more than 5 minutes without the blower running or damage may occur to the blower motor.

ANTES DE UTILIZAR EL EQUIPO

Funcionamiento del control remoto:
Cuando arranque el equipo, **PRIMERO ENCIENDA EL COMPRESOR** y luego el agitador. Cuando apague el equipo, **PRIMERO APAGUE EL AGITADOR** y luego el compresor.

IMPORTANTE: no permita que el agitador funcione por más de 5 minutos sin que el compresor esté en funcionamiento; de lo contrario, se pueden producir daños en el motor del compresor.

THE FORCE/1 *Claims, Damage or Loss*

These goods were carefully packed and thoroughly inspected before leaving our factory. Responsibility for its safe delivery was assumed by the carrier upon acceptance of the shipment. Inspect shipment carefully on the arrival for damage to contents, shortages or equipment. In case of damage, save container and packing material for inspection. Claims for loss or damage sustained in transit must, therefore, be made upon the carrier, as follows:

1. CONCEALED LOSS OR DAMAGE. Concealed loss or damage means loss or damage which does not become apparent until the merchandise has been unpacked. The contents may be damaged in transit due to rough handling even though the carton may not show external damage. When the damage is discovered upon unpacking, make a written request for inspection by the carrier's agent within ten days of the delivery date. Then file a claim with the carrier since such a claim is the carrier's responsibility.

2. VISIBLE LOSS OR DAMAGE. Any external evidence of loss or damage must be noted on the freight bill or the express receipt, and signed by the carrier's agent. Failure to adequately describe such external evidence of loss or damage may result in the carrier refusing to honor a damage claim. The form required to file such a claim will be supplied by the carrier.

3. SHORTAGE. If the number of containers in the shipment does not correspond with the transportation bill, obtain carrier's notation of shortage and signature on transportation bill. When the number of containers is correct, but there is indication of pilferage, notify carrier in writing with a complete list of missing merchandise.

THE FORCE/1

Claims, Damage or Loss

Claims for loss or damage must be filed with the carrier by the consignee **within 24 hours after receipt of goods.** We will assist you in every possible manner but cannot be responsible for the collection of a claim or the cost of replacement of the damaged goods.

If you have any questions regarding the above information please feel free to contact an INTEC representative.

RETURNS

We at INTEC sincerely hope the merchandise you have just received is in excellent condition and satisfies your expectations. If not, please look below and follow the instructions which apply to your particular situation.

MERCHANDISE IS DAMAGED.

If the carrier is UPS:

Keep the merchandise in the original packing materials and carton.

Call UPS at (800) 742-5877 or contact them using their web address: www.ups.com/using/custserv/ to notify them of the damaged package.

Fill out the information sheet on the following page and mail or fax it to the attention of the Shipping Department.

Upon return of this form and/or the damaged merchandise, we will send a replacement or credit your account.

Other than UPS:

Keep the merchandise in the original packing materials and carton.

Call the Shipping Department at the number on the following page for further instructions.

Upon return of this form and/or the damaged merchandise by the carrier, we will send you a replacement or credit your account. Do not return any merchandise through the U.S. Post Office.

MERCHANDISE IS PERSONALLY UNSATISFACTORY TO YOU.

You may return the merchandise, along with a RMA number on outside of carton and a copy of your invoice to the Shipping Department at the address provided on the next page. Upon its return intact, we will send a refund or credit your account. A restocking fee may be charged.

THE FORCE/1

Returns

SHIPMENTS TO FACTORY

All shipments to the factory must have a RMA number on the outside of the carton. You will be given a RMA number when you contact the Sales Department. The RMA is the only way to track and assure that your request is handled properly. If you received an invoice with your merchandise, please include a copy of the invoice with all returned materials.

Company Name _____

Contact Name _____

Phone _____ Fax _____

Address _____

City _____ State _____ Zip _____

Comments _____

Invoice Number _____ RMA Number _____

Shipping Department	Ph: 1-303-833-6644
INTEC	1-800-666-1611
3771 Monarch Street	Fax: 1-303-833-6650
Frederick, CO 80530	E-mail: info@inteccorp.com

THE FORCE/1

Replacement Parts

When you call INTEC, please have available the model number and serial number of your machine, as well as description of the defective part or an explanation of the defect.

We will issue a **Return Merchandise Authorization (RMA)** number and instructions to return the defective part. All shipments to INTEC must be sent via UPS, except in the case of complete machines, when a common carrier should be used. The warranty on your machine does not cover **freight** or **labor charges**. All shipments to the factory or service center must be freight prepaid. No freight collect shipments will be accepted without prior approval.

Your RMA number must appear on the outside of any returned cartons. We assume no responsibility for incoming lost or untraceable shipments. RMA numbers expire 30 days after issue date. Shipments beyond the 30-day expiration may not be credited.

We will repair or replace, at our option, any returned part found to be defective in materials or workmanship under the terms of our limited warranty. Repaired or replaced parts will be returned to you freight collect.

If we determine the part failure was due to misuse, alteration, negligence, accident or operating beyond rated capacity, we will contact you. At your option, we will send you a new part at the prevailing price or return the failed part to you. All shipments from the factory are sent freight collect.

If you require a replacement part prior to a warranty decision, we will send the part to you at the prevailing price, under your current terms. When we receive the defective part and a warranty decision has been made, INTEC will either issue a credit to your account or return the failed part to you.

Shipping Department	Ph: 1-303-833-6644
INTEC	1-800-666-1611
3771 Monarch Street	Fax: 1-303-833-6650
Frederick, CO 80530	E-mail: info@inteccorp.com

THE FORCE/1

Warranty

It is expressly understood and agreed that no officer, agent, salesman or employee of the Manufacturer INTEC has the authority to obligate the Manufacturer by any terms, stipulations, or conditions not herein expressed; that all previous representations and agreements, either verbal or written, referring to the machinery and equipment, which is the subject of this Warranty, are hereby superseded and canceled, and that there are no promises or agreements outside of this Warranty agreement. Furthermore, the Manufacturer hereby disclaims any implied warranties of merchantability, or implied warranties of fitness for a particular purpose.

With the above understanding, the Manufacturer's FORCE/1 insulation blowing machine is sold with the following one (1) year Limited Warranty, and no other:

- a) Manufacturer warrants to the original purchaser that the machine is well made, of good material and durable; but only if the machine is operated and maintained in accordance with this Operator's Manual and the Maintenance Manual. This Warranty is void if the machine is not so operated and maintained, or if the machine is used for blowing materials other than those which are intended to be used with the machine.
- b) Manufacturer guarantees the machine to be free from manufacturing defects at the time of shipment, and to remain free from defects when operated under normal use, for a period of one (1) year from the date of factory shipment, with the exception of the blower, electrical and air lock components, which are guaranteed for a period of ninety, (90) days from date of factory shipment.
- c) This Warranty shall not apply to any machine or component part which, in the opinion of the Manufacture, has been altered, subject to misuse, negligence, accident or operated beyond factory rated capacity. All requested Warranty work shall be performed at Manufacturer's factory or by an Authorized Factory Service Facility. Failure to have the Warranty work done at Manufacturer's factory or by an Authorized Factory Service Facility will void this Warranty. Manufacturer will bear full responsibility to repair or replace, at its option, without charge to the original purchaser, any part which, in the Manufacturer's opinion, is found to be defective.
- d) All parts claimed defective by original purchaser shall be returned, properly identified, to Manufacturer's factory or Authorized Factory Service facility, freight prepaid. All replacement, repaired or non-defective parts will be returned to purchaser, freight collect. Manufacturer will supply replacement parts prior to receipt of my parts claimed defective, only with the understanding that such replacement parts will be shipped to purchaser at the then prevailing price of said part, C.O.D., freight collect. Manufacturer will reimburse cost of any such part only after receipt and inspection, and finding said part defective.
- e) Manufacturer's liability is expressly limited to the repair or replacement of defective parts set forth in this Warranty. All other damages and warranties, statutory or otherwise, being waived by original purchaser as a condition of sale and purchase of said machines. Furthermore, the Manufacturer shall not be liable for damages or delays caused by defective material or workmanship.

This Warranty is effective only for the original purchaser and is not transferable.

THE FORCE/1

Insulation Terms and Values

R-VALUE: The resistance (R) to heat or cold. The higher the R-Value, the greater the resistance and the better the insulation factor.

SETTLEMENT: All blown insulation will settle after installation. Your FORCE/1 installs near settled density. Consult the chart on the material bag for coverage and install accordingly.

COVERAGE: Every bag of material comes with a coverage chart detailing R-Value ratings. Average ratings for various materials are:

Cellulose: R = 3.7 per inch

Rockwool: R = 2.6 per inch

Fiberglass: R = 2.2 per inch

CFM: Blowers are measured by Cubic Feet per Minute. A low CFM blower reduces “dust” when blowing insulation into an attic. The FORCE/1 features the lowest CFM of all insulation blowing machines, minimizing the “dust” problem. You'll be able to see what you are doing.

PSI: Blowers are also rated by Pounds of pressure per Square Inch. A high PSI does a better job of blowing insulation. Your FORCE/1 produces 2.5-3.0 PSI which is the best for blowing insulation.

BRIDGING: A pocket of air, or void, created by improper agitation in the hopper. A “bridge” can stop production until cleared. Your FORCE/1 is designed with a non-bridging hopper. However, you may experience a temporary bridge while using your machine. Waiting a few seconds will most likely clear a temporary bridge. If not, unplug your machine and redistribute the material in the hopper.

VENTILATION: Proper air flow requires one square foot of air movement for every 150 square feet of attic area.

THE FORCE/1

Insulation Terms and Values

COMMON INSULATION VALUES

Material	Thickness	R-Value
Air Space	1"	1.01
Cellulose loose fill	1"	3.70
Celotex	1"	3.03
Concrete block	8", hollow	1.11
Fiberglass batt	3½"	11.0
Fiberglass batt	8"	19.0
Fiberglass loose fill	1"	2.2
Rockwool batt	¾"	11.0
Rockwool batt	6 - 7½"	22.0
Rockwool loose fill	1"	2.60
Plywood	½"	.62
Polyurethane board	1"	6.25
Vermiculite	1"	2.13