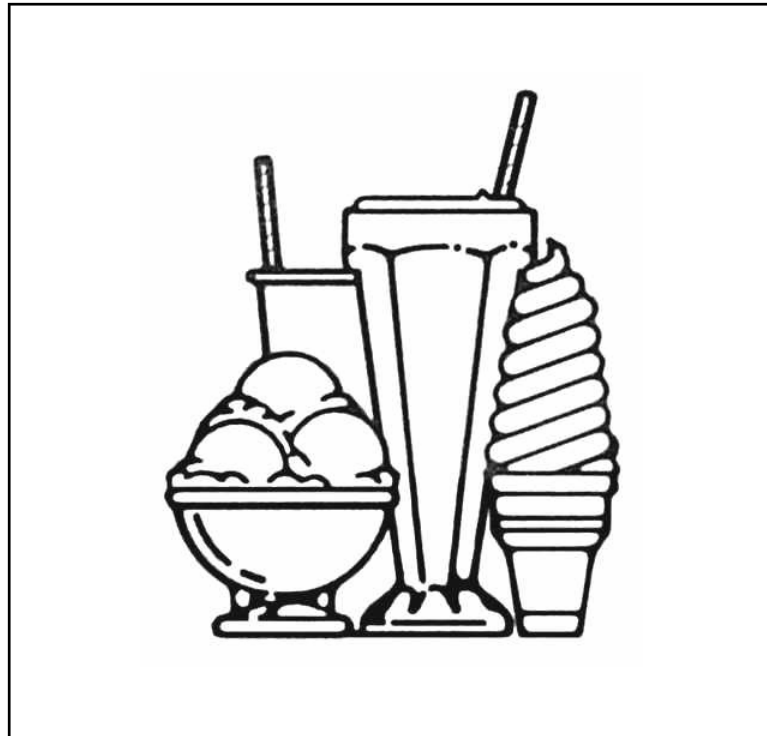


SaniServ®

 An AFFINIS GROUP Company

“Reliability from the team that Serves the Best”



Soft Serve and Shake Dispenser

Operation Manual

SaniServ P.O. Box 1089 Mooresville, Indiana 46158

Distributor Name: _____

Address: _____

Phone: _____

Date of Installation: _____

Model Number: _____

Serial Number: _____

Installer/Service Technician: _____

SERVICE: Always contact your SaniServ dealer or distributor for service questions or service agency referral. If your SaniServ dealer or distributor cannot satisfy your service requirements, he is authorized to contact the factory for resolution.

PARTS: Always order parts from your SaniServ dealer or distributor. When ordering replacement parts, specify the part numbers, give the description of the part, the model number and the serial number of the machine.

WARRANTY: Remove the Check Test Start (CTS) form and fill it out in its entirety. Return the original (white) copy to SaniServ. Dealer/Distributor retain second (yellow) copy and Owner/Operator retain third (pink) copy.

The Manufacturer's Limited Warranty is printed on the reverse side of the Owner/Operator copy.

IMPORTANT

TO VALIDATE THE WARRANTY, THE CTS FORM MUST BE COMPLETED AND RETURNED TO THE FACTORY WITHIN 30 DAYS OF INSTALLATION.

Note: The Check Test Start function must be performed by a qualified technician.

Table of Contents

| | |
|---|----|
| Introduction | 1 |
| Installation | 1 |
| Installer's Preoperational Check | 2 |
| Disassembly and Cleaning | 3 |
| Assembly and Lubrication | 6 |
| Sanitizing | 9 |
| Operation | 9 |
| Helpful Hints | 11 |
| Mechanical Consistency Control System | 12 |
| Electronic Consistency Control System | 13 |
| Routine Maintenance | 14 |
| Troubleshooting | 16 |

Illustrations

| | |
|--|----|
| Fig. 1 Leg Installation | 1 |
| Fig. 2a Front Plate Assembly | 2 |
| Fig. 2b Dasher Assembly | 2 |
| Fig. 2c Control Switch | 2 |
| Fig. 3 Carburetor Tube | 3 |
| Fig. 4 Dispensing Product | 3 |
| Fig. 5 Front Plate Assembly | 4 |
| Fig. 6 O-Ring Removal | 4 |
| Fig. 7 Carburetor Tube | 4 |
| Fig. 8 Dasher Assembly | 4 |
| Fig. 9a Scraper Blade Removal | 5 |
| Fig. 9b Scraper Blade Removal | 5 |
| Fig. 10 Mix Pan Agitator | 5 |
| Fig. 11 Drip Tray Assembly | 5 |
| Fig. 12 Stator Rod and Dasher Lubrication | 6 |
| Fig. 13 Dasher Assembly | 6 |
| Fig. 14 Scraper Blade Installation and Wear Mark | 6 |
| Fig. 15 Dasher Installation | 7 |
| Fig. 16 Dasher Installation | 7 |
| Fig. 17 Dasher (Front View) | 7 |
| Fig. 18 Spigot Plunger Lubrication | 7 |
| Fig. 19 Front Plate Assembly | 8 |
| Fig. 20 Mix Pan Probe | 8 |
| Fig. 22 Carburetor Tube | 8 |
| Fig. 23 Mix Pan Components | 9 |
| Fig. 24 Dispensing Product | 9 |
| Fig. 25 Drip Tray Assembly | 8 |
| Fig. 26 Carburetor Tube | 10 |
| Fig. 27 Water Cooled Condenser Valve | 11 |
| Fig. 28 Mechanical Consistency Control | 12 |
| Fig. 29 Electronic Consistency Control | 13 |
| Fig. 30 Scraper Blade Wear Mark | 14 |
| Fig. 31 Drip Chute | 14 |
| Fig. 32 Clean Sharp Condenser Fins | 14 |
| Fig. 33 Torque Spring Adjustment Mechanism | 15 |

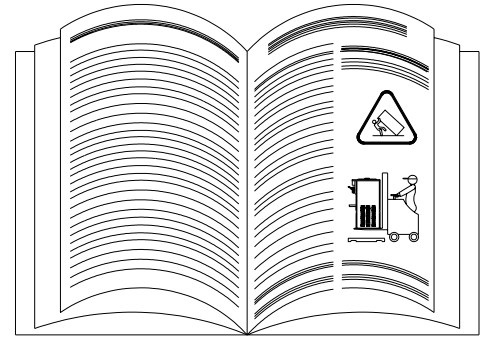
Introduction

This manual provides a general system description of the SaniServ Soft Serve and Shake Dispensers. It has been prepared to assist in the training of personnel on the proper installation, operation, and maintenance of the machines.

Read and fully understand the instructions in this manual before attempting to install, operate, or perform routine maintenance on the machines.

The following sections of the manual must be performed in sequence:

1. Installation
2. Installer's Preoperational Check
3. Disassembly & Cleaning
4. Assembly & Lubrication
5. Sanitizing & Operation
6. Consistency Adjustment



Installation



WARNING

ALWAYS USE A SUFFICIENT NUMBER OF PEOPLE OR MECHANICAL LIFTING EQUIPMENT TO PROTECT ALL PERSONNEL FROM PERSONAL INJURY DURING THE REMAINING STEPS.

1. Raise the machine to install the four legs packed in the mix pan or the four casters packed in a box on the skid or on the front mounted drip tray. **Be certain all four are tight! Thread lock is suggested.**
2. Carefully lower the machine to the floor and place it where it will be installed.
3. Level the unit by turning the bottom part of each leg clockwise or counterclockwise (Fig. 2). The machine **MUST** be level to operate properly.

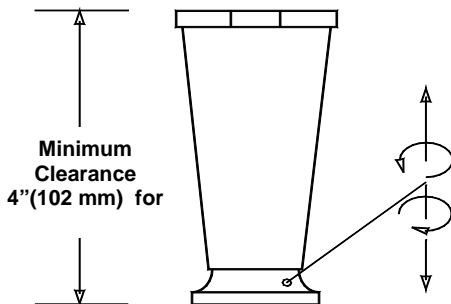


Fig. 1

THESE UNITS MUST NOT BE OPERATED WITHOUT LEGS INSTALLED OTHERWISE BOTTOM AIRFLOW TO THE CONDENSER WILL BE RESTRICTED.

A MINIMUM 6" (152 MM) CLEARANCE MUST BE MAINTAINED AT THE REAR AND SIDES OF THE MACHINE FOR ADEQUATE VENTILATION.

4. Electrical and refrigeration specifications are located on the data plate on the rear of the individual machines. Consult local authorities for information regarding plumbing and electrical codes in the area.

Note: All SaniServ machines should have their own dedicated circuits whether they are cord connected plug-in devices or hard wired units.

IMPORTANT

ALWAYS CHECK ELECTRICAL SPECIFICATIONS ON THE DATA PLATE OF THE MACHINE. DATA PLATE SPECIFICATIONS ALWAYS SUPERSEDE ELECTRICAL INFORMATION IN THIS MANUAL.

5. The water line connections on water-cooled machines are located on the back side of the machine. The **IN/OUT** lines are clearly marked and have 1/4" male pipe threads fitted with a 3/4" garden hose fitting.

Note: These water lines are installed on water-cooled machines only.

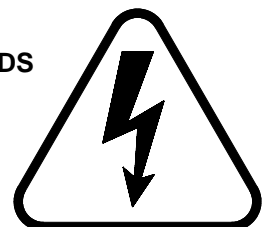


WARNING

FAILURE TO PROVIDE FOR PROPER EARTH GROUND ACCORDING TO LOCAL APPLICABLE ELECTRICAL CODES COULD RESULT IN SERIOUS ELECTRICAL SHOCK OR DEATH.

DO NOT USE EXTENSION CORDS

DO NOT TURN MACHINE ON



Installer's Preoperational Check

THE FOLLOWING ITEMS MUST BE PERFORMED BEFORE ATTEMPTING TO OPERATE THE EQUIPMENT.



WARNING

1. Make certain that proper electrical connections have been made. Plug power cord into power outlet.
2. Set each control switch (Fig. 2) to the “**CLEANOUT**” position momentarily to verify the direction of rotation of the dasher. It should rotate counter-clockwise.
3. Set each control switch to the “**OFF**” position.

In the event the dasher turns clockwise, **STOP** and do not proceed any further. On three-phase units, reverse the polarity.

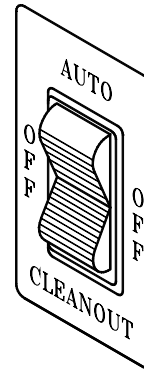


Fig. 2
Control Switch



CAUTION

UNDER NO CIRCUMSTANCES SHOULD THE UNIT BE OPERATED IN THE “AUTO” POSITION FOR MORE THAN THREE MINUTES WITH EMPTY FREEZING CYLINDERS. DOING SO WILL RESULT IN DAMAGE TO THE MACHINE.

Disassembly & Cleaning

CONSULT YOUR LOCAL HEALTH AGENCY FOR CLEANING AND SANITIZING REQUIREMENTS.

This unit does not come presanitized from the factory. Before serving product, the dispenser must be disassembled, cleaned, lubricated, and sanitized. These instructions are general guidelines only. Cleaning and sanitizing procedures must conform to local health agency requirements.

Emptying Machine

Prior to the disassembly and cleaning of parts, the machine must be emptied of product. Use the following procedures (Steps 1 through 3). If this is first time operation, disregard these steps.



WARNING

DO NOT INSERT ANY OBJECTS OR TOOLS INTO THE MIX INLET HOLE, CARBURETOR TUBE HOLE, OR FRONT PLATE DISPENSING HOLE WHILE THE MACHINE IS RUNNING. DAMAGE TO THE MACHINE OR PERSONAL INJURY MAY RESULT.

1. Remove the carburetor tube (Fig. 3) from the mix inlet hole and lay in the bottom of the mix pan.
2. Set the control switch to the “**CLEANOUT**” position and dispense all product from the freezing cylinder by pulling downward on the spigot handle (Fig. 4) to empty the machine.
3. Set the control switch to the “**OFF**” (center) position. Close the spigot handle before proceeding to cleaning.

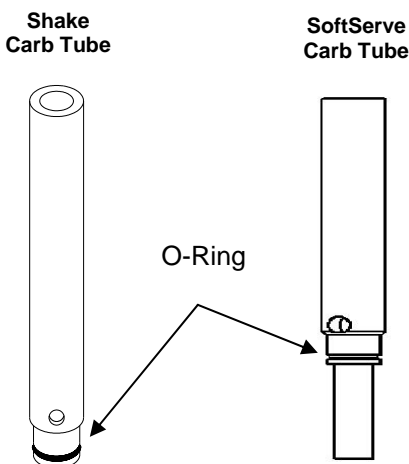


Fig. 3
Carburetor Tubes

Disassembly and Cleaning Procedure

1. Fill the machine with cold water and set the control switch to the “**CLEANOUT**” position. **DO NOT** use hot water which could damage the machine. Let the machine agitate briefly and drain the water by pulling downward on the spigot handle. After the machine is empty, set the control switch to the “**OFF**” position. Repeat the above procedure as necessary to make certain that all product is removed from the machine.
2. Prepare a suitable detergent and water solution at a temperature of 125° to 130° F. **DO NOT** use an abrasive detergent on any part of the dispenser.

IMPORTANT

**DO NOT USE HOT WATER
DOING SO COULD DAMAGE YOUR MACHINE**

3. Fill the mix pan with the cleaning solution. Make certain that the machine is “**OFF**”. Clean the mix pan thoroughly with a brush as the solution drains into the freezing cylinder. Clean the mix inlet tube and the carburetor tube holes with the brush provided.

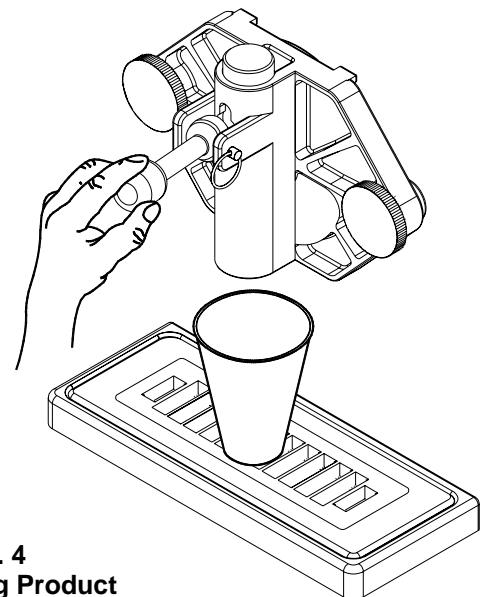


Fig. 4
Dispensing Product

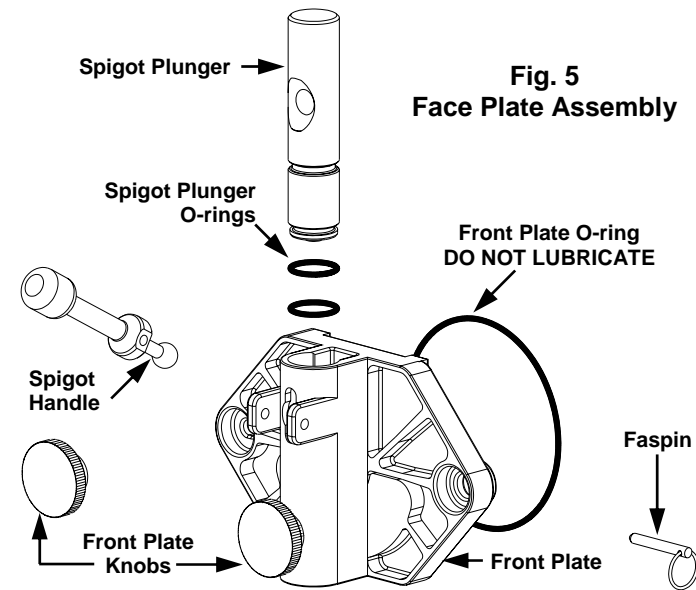
4. Set the control switch to the “**CLEANOUT**” position and agitate for approximately 1 - 2 minutes and then drain the water by opening the spigot. After the unit is empty, set the control switch to the “**OFF**” position.

5. Remove the front plate by turning the black plastic knobs in a counterclockwise direction (Fig. 5). Disassemble the front plate in the following manner:

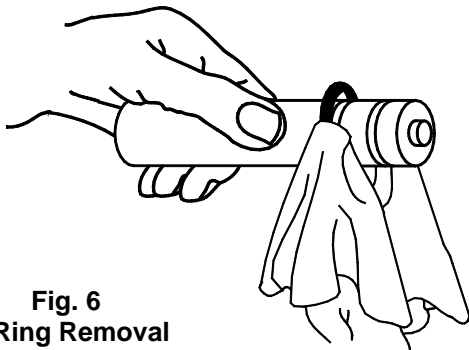
IMPORTANT

DO NOT USE ANY TOOLS OR SHARP OBJECTS TO REMOVE ANY O-RINGS FROM THIS MACHINE. SHARP OBJECTS WILL DAMAGE THE O-RINGS.

- a. Remove the faspin and spigot handle.
- b. Remove the front plate o-ring.
- c. With the spigot handle removed, push the spigot plunger out the top of the front plate.
- d. Remove the o-rings from the spigot plunger by grasping the part with one hand and with a dry cloth in the other hand, squeeze the o-ring upward. When a loop is formed, grasp the o-ring with the other hand and roll it out of its groove and off the part (Fig. 6).

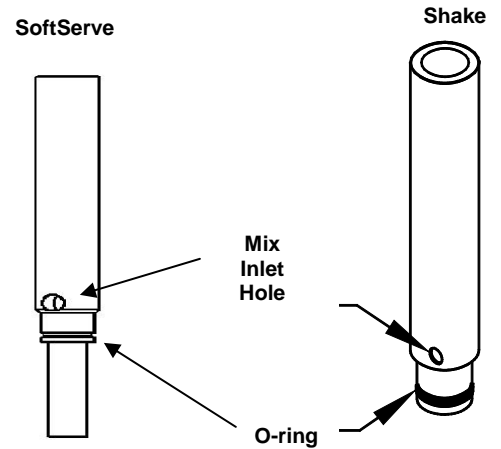


**Fig. 6
O-Ring Removal**



6. Remove the carburetor tube (Fig. 7) from the mix pan. Disassemble and clean in the following manner:

- a. Remove the o-ring from the bottom of the tube.
- b. Clean the inside of the tube with the brush.

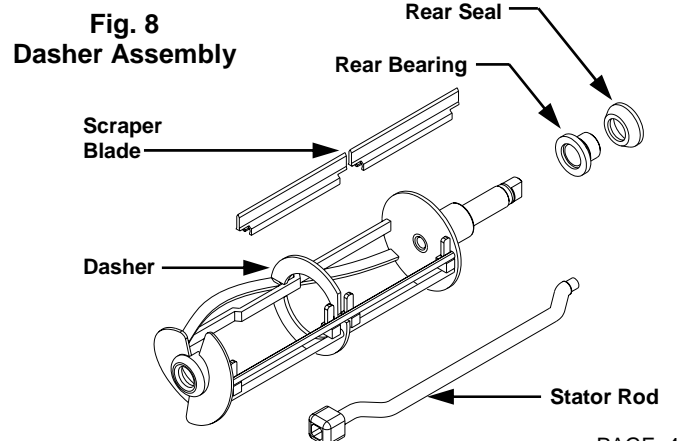


**Fig. 7
Carburetor Tube Assembly**

7. Remove the dasher assembly (Fig. 8) being careful not to damage the scraper blades, then disassemble in the following manner:

- a. Remove and take apart the rear seal assembly.
- b. Remove the stator rod from the dasher.
- c. Remove the blades from the dasher (Fig. 9a) by first rotating blade upward (Fig. 9b) and then unsnapping one end from the support rod.

BLADES MUST BE REMOVED FOR CLEANING.



**Fig. 8
Dasher Assembly**

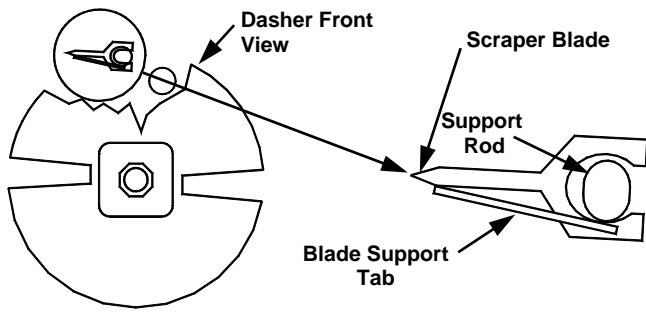


Fig. 9a
Scraper Blade Removal

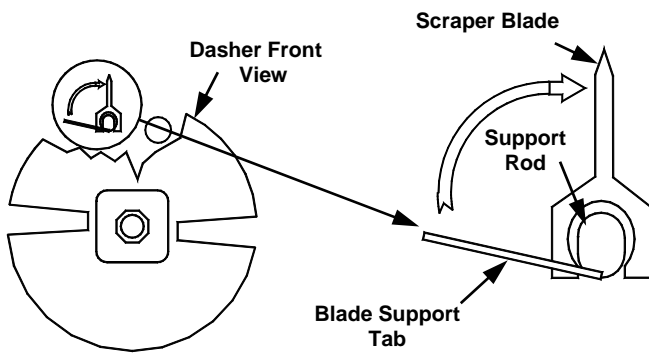


Fig. 9b
Scraper Blade Removal

9. Remove the mix pan lid, mix pan agitator, drip tray and drip tray insert. Place all parts in a three partition sink filled with the following solutions:

- a. In one partition, mild detergent solution.
- b. In a second partition, clear rinse.
- c. In a third partition, sanitizing rinse consisting of 200 parts per million (PPM) chlorine residual.

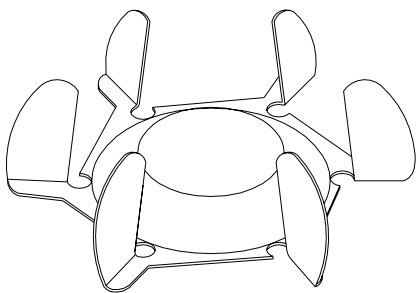


Fig 10
Mix Pan Agitator

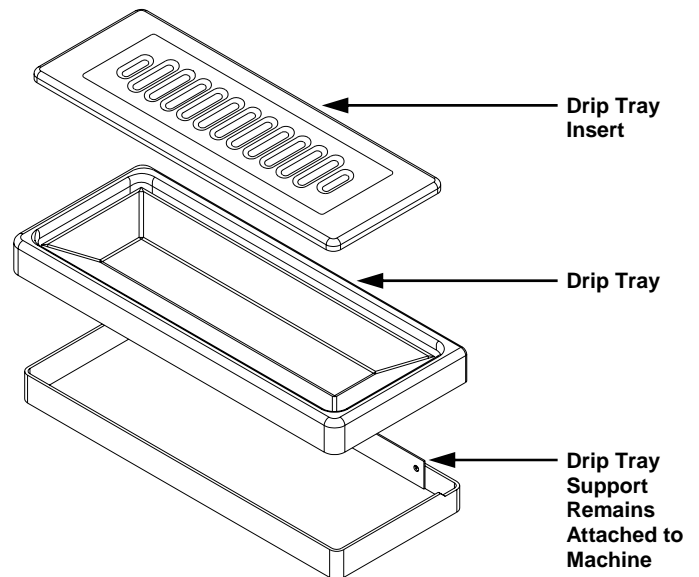


Fig. 11
Drip Tray Assembly

10. Use the small diameter brush to clean all holes and ports in the parts. **DO NOT** use an abrasive detergent.

11. After thoroughly washing the parts in the detergent solution, rinse them in the rinse water. Place the parts in the sanitizing solution for five (5) minutes and then air dry to prepare for assembly and lubrication. **DO NOT** wipe dry.

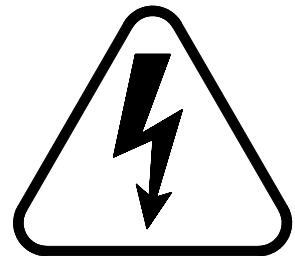
12. The remainder of the machine including the mix pan and freezing cylinder must be cleaned in place using a mild detergent solution. Clean the exterior with a damp cloth. **DO NOT** use an abrasive cleaner on exterior panels.



WARNING

WHEN CLEANING THE MACHINE, DO NOT ALLOW EXCESSIVE AMOUNTS OF WATER AROUND ANY ELECTRICALLY OPERATED COMPONENTS OF THE MACHINE. ELECTRICAL SHOCK OR DAMAGE TO THE MACHINE MAY RESULT.

ELECTRICAL
SHOCK HAZARD



Assembly & Lubrication

Use only food approved lubricants. Haynes Lubri-Film (SaniServ part no. 1150) is recommended and is available from your local authorized SaniServ dealer or distributor. **Lubrication must be performed daily.**

1. Lubricate and assemble the dasher assembly in the following manner:

a. Apply a generous amount of lubricant to the shoulder of the dasher and the area of the shaft where the white plastic portion of the assembled rear seal contacts the shaft (Fig. 12). This is easily performed by running a 1/4" bead of lubricant around the shoulder of the dasher.

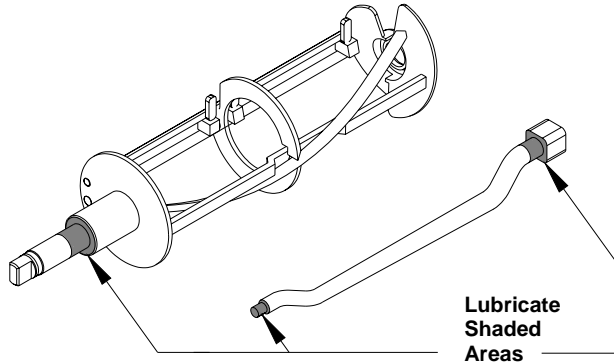


Fig. 12
Stator Rod and Dasher Lubrication

b. Lubricate the two areas of the stator rod (Fig. 12) and slide the stator rod into the dasher (Fig. 13). Be certain that the end of the stator rod is inserted into the hole at the rear of the dasher (Except on Model 407).

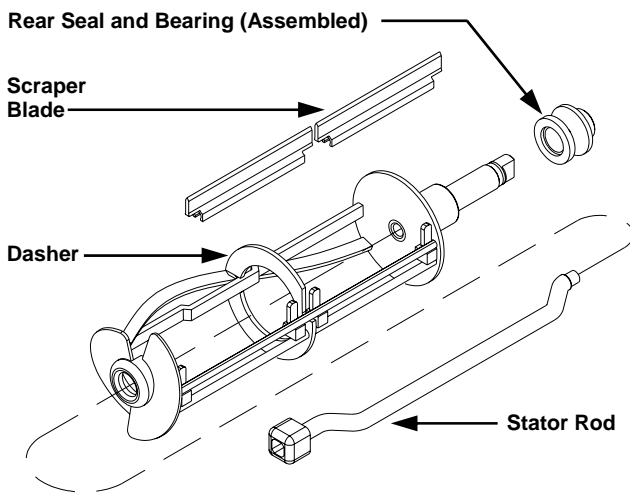


Fig. 13
Dasher Assembly

c. Assemble and install the rear bearing and seal with the rubber portion toward the rear of the freezing cylinder as indicated in Fig. 13.

CAUTION

DO NOT LUBRICATE THE BACK SIDE OF THE RUBBER PORTION OF THE SEAL ASSEMBLY. MACHINE COULD BE DAMAGED.

d. Install the scraper blades on the dasher assembly by holding the blade perpendicular to the tabs (Fig. 14a) and then snapping them over the flat area of the support rod. Then rotate the blade downward in a counterclockwise direction as viewed from the front of the dasher (Fig. 14b).

Note: Reverse the blades at each cleaning to maintain sharpness. In addition, the blades are equipped with a wear mark (Fig. 14c). When the blade is worn to this wear mark, they must be replaced.

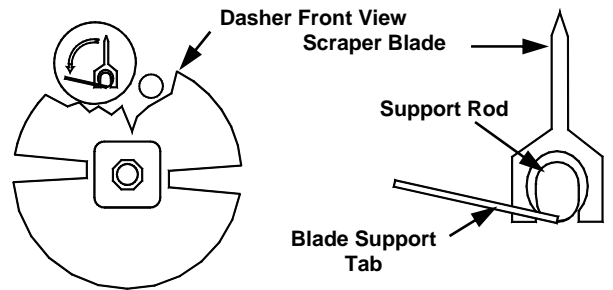


Fig. 14a
Scraper Blade Installation

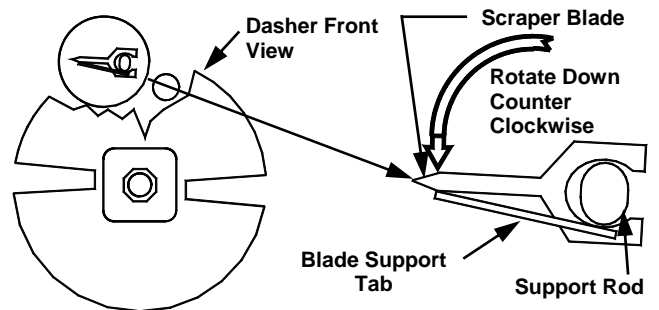


Fig. 14b
Scraper Blade Installation

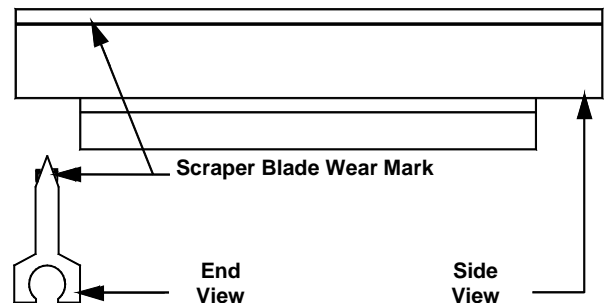


Fig. 14c
Scraper Blade Wear Mark

e. Insert the dasher assembly into the freezing cylinder as far as possible (Fig. 15) being careful not to damage the scraper blades. Damage will occur to the scraper blades and the dispenser will not operate properly if the scraper blades are installed facing in a clockwise direction (Fig. 16).

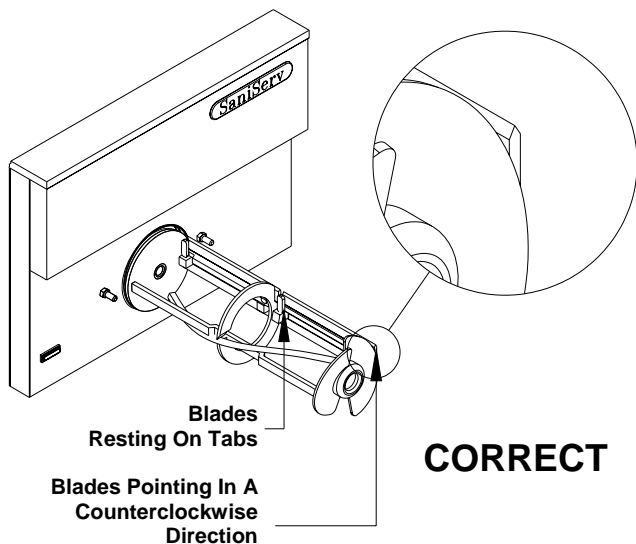


Fig. 15
Dasher Installation

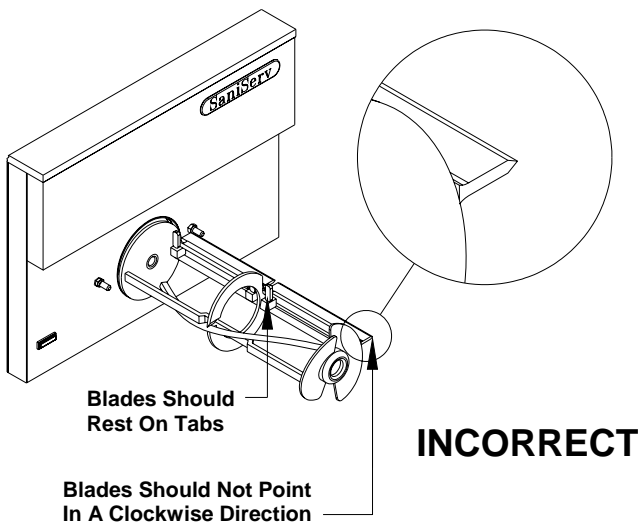


Fig. 16
Dasher Installation

Note: The stator rod has been deleted from Fig. 15 and Fig. 16 for clarity only. They must be installed for proper machine operation.

f. While maintaining force against the dasher, rotate it slowly until the tongue of the dasher engages the groove in the drive system at the rear of the cylinder. The outer most portion of the dasher should be recessed approximately 1/4" to 3/8" inside the freezing cylinder. No part of the dasher should extend outside the cylinder. Scraper blades should be visible (Fig. 17) extending approximately 1/8" beyond the dasher.

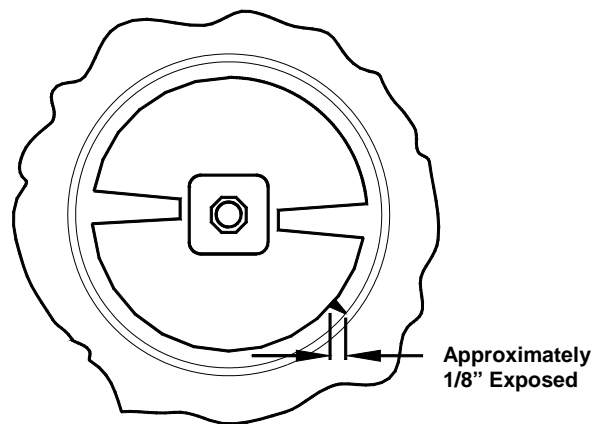


Fig. 17
Dasher with Blade (Front View)

2. Lubricate and assemble the front plate assembly in the following manner:

a. Install the two o-rings on the spigot plunger by rolling them onto the plunger. Seat the o-rings in the grooves. Make certain that they are not twisted. Smooth the lubricant into the grooves and over the sides of the plunger assembly (Fig. 18).

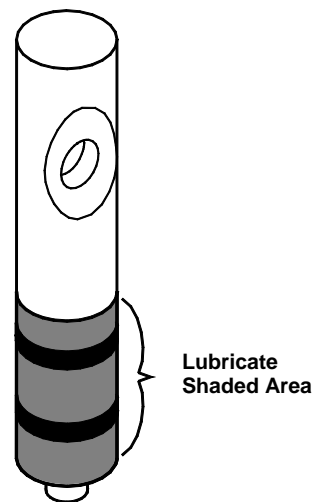


Fig. 18
Spigot Plunger Lubrication

b. Slide the lubricated spigot plunger into the front plate (Fig. 19) Align the spigot handle slot to the front.
c. Insert the spigot handle and secure with the faspin.
d. Install the front plate o-ring.

CAUTION

**DO NOT LUBRICATE THE FRONT PLATE O-RING
LUBRICANT WILL MAKE THE FRONT PLATE LEAK**

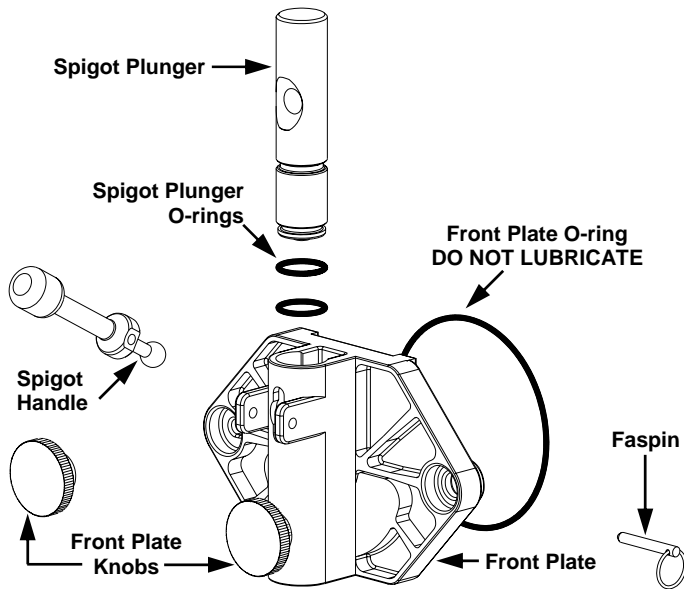


Fig. 19
Front Plate Assembly

e. Align the front plate to the freezing cylinder, place the square pocket on the back side of the front plate over the end of the stator rod, and secure the front plate assembly to the machine with the two plastic knobs. Turn both of the knobs in a clockwise direction simultaneously. Tighten the knobs evenly. **DO NOT** tighten one knob all the way down and then the other. Doing so may result in front plate breakage. Only moderate force is required. **DO NOT** over tighten. Set the spigot plunger to the closed position.

IMPORTANT

3. **DO NOT** apply lubrication to the Mix out probe located in the mix pan - see Fig. 20.

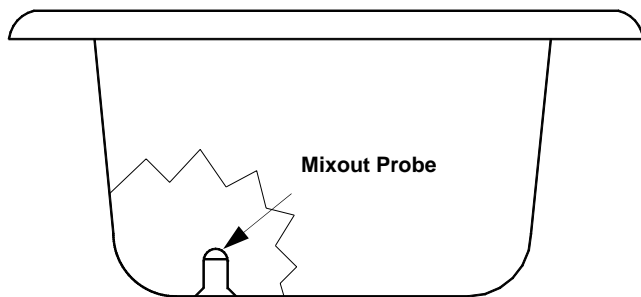


Fig. 20
Mix Pan Probe

4. Install the o-ring on the carburetor tube (Fig. 22). Apply lubricant sparingly over the o-ring. Install the insert tube in the housing tube with a gentle twisting motion. Place the carburetor tube in the bottom of the mix pan for sanitizing.

Lubricant MUST NOT BLOCK the mix inlet hole on the carburetor tube.

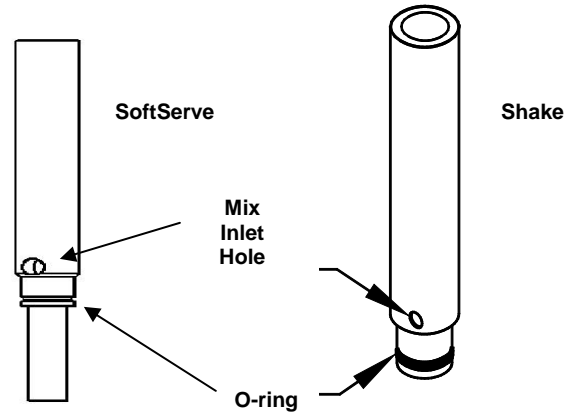


Fig. 22 Carburetor Tube

5. Apply a small amount of lubricant to the bottom of the mix pan agitator. Place the lubricated mix pan agitator into the right front corner of the mix pan (right rear corner on Model 407) Position the mix pan agitator until you feel the magnets of the agitator engage the magnets of the drive system beneath the mix pan.

DO NOT apply lubrication to the Mixout probe located in the mix pan.

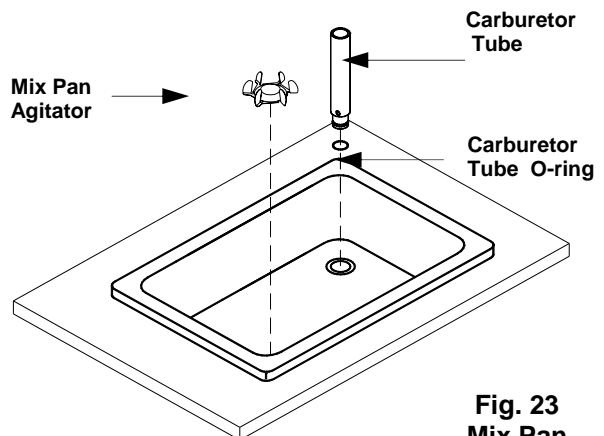


Fig. 23
Mix Pan Components

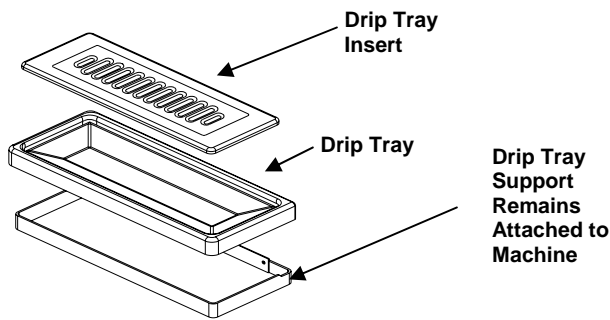


Fig. 24
Drip Tray Assembly

6. Install the drip tray and drip tray insert.

Sanitizing

Prior to operation, the machine must be sanitized. The unit must have already been cleaned and lubricated.

Note: Sanitize immediately before use, not several hours before or the previous evening.

1. Wear eye protection. Wash hands with a suitable antibacterial soap.

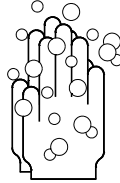
2. Prepare 2 to 3 gallons of sanitizing solution equivalent to 200 ppm chlorine residual - check local requirements.

3. Pour the solution into the mix pan.

4. Using a sanitary brush, wipe the solution onto the sides of the mix pan, over the mix out probe, and the underside of the lid.

5. Set the control switch to the "CLEANOUT" position and let the unit agitate for approximately 3 to 5 minutes.

NOTE: DO NOT set the control switch to the "AUTO" position. Doing so would freeze the sanitizing



WARNING

DO NOT INSERT ANY TOOLS OR OBJECTS INTO THE MIX INLET HOLE, CARBURETOR TUBE HOLE, OR THE DISPENSING HOLE IN THE FRONT PLATE. DAMAGE TO THE MACHINE OR PERSONAL INJURY MAY RESULT.

6. Set the control switch to the "OFF" position and drain the solution from the machine. Proceed directly to the "Operation" section of this manual.

IMPORTANT

DO NOT RINSE OUT THE MACHINE

Operation

Always start with a cleaned and sanitized dispenser as per previous instructions. Use only fresh mix when charging the units. Following these instructions is critical to the maximum operating efficiency of the machine.

1. Remove the carburetor tube from the bottom of the mix pan and set aside in a sanitary location.

2. Place a 16 oz. Cup under the spigot and open the spigot handle. Pour approximately one quart of fresh product mix into the mix pan. (This will chase the sanitizing solution from the mix pan and freezing cylinder.) Close the spigot handle when the sanitizer is purged from the system.

3. Once the sanitizer solution has been purged from the machine, fill the mix pan full of product mix.

NOTE: DO NOT POUR SHAKE OR SOFT SERVE PRODUCT MIX DIRECTLY ONTO THE MIX PAN AGITATOR WHEN YOU FILL THE MACHINE.

4. Install the carburetor tube into the hole in the mix pan with a gentle twisting motion

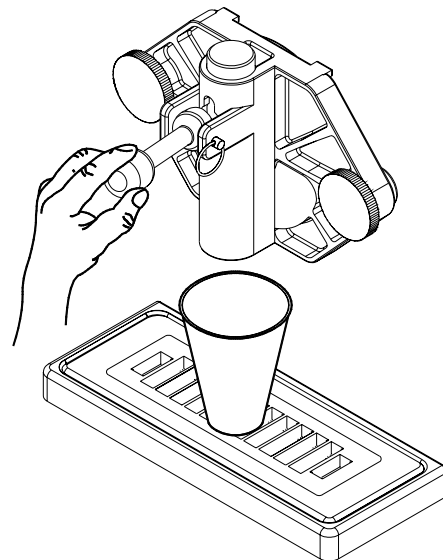


Fig. 25
Dispensing Product

5. On mechanical consistency control machines, set the control switch to the **“CLEANOUT”** position for approximately 1-1/2 seconds (a click can be heard) and then move the switch rapidly to the **“AUTO”** position.

On electronic consistency control machines, it is not necessary to select the **“CLEANOUT”** position prior to the **“AUTO”** position. Simply move the control switch directly from the **“OFF”** position to the **“AUTO”** position and the unit will start.

On three phase mechanical consistency control units, set the control switch to **“AUTO”**, then raise the spigot plunger to start the refrigeration cycle.

IMPORTANT

On combination machines, the shake side is on the left and the soft serve side is on the right (facing the machine).

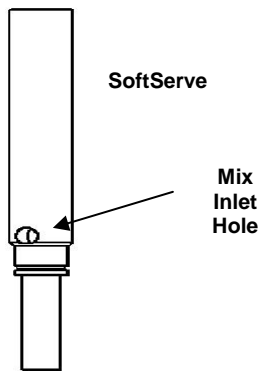


Fig. 26 Carburetor Tube

CAUTION

WHEN DISPENSING PRODUCT, MAKE CERTAIN THE HOLE IN THE CARBURETOR TUBE (Fig. 27) IS OPEN AT ALL TIMES. IF NOT OPEN, THE FLOW OF MIX WILL BE RESTRICTED. IF THIS HAPPENS, THE PRODUCT MIX COULD FREEZE TOO HARD CAUSING DAMAGE TO THE MACHINE.

ALSO, LUBRICANT BLOCKING THE HOLE IN THE CARBURETOR TUBE WILL CAUSE DAMAGE.

6. Allow the compressor to cycle 3-4 times dispensing a sample of the product after each cycle to check for consistency. If the machine is not dispensing the product at the desired consistency after four full cycles, refer to the Consistency Control Section of this manual. Initial pull-down time is 12-15 minutes, but may vary due to product mix and ambient conditions.

7. Replace the mix pan lid and always operate the machine with the lid on the mix pan reservoir.

IMPORTANT

NOTE: WHEN REFILLING THE MIX PAN DURING DAILY OPERATION, DO NOT POUR SHAKE OR SOFT SERVE MIX DIRECTLY ONTO THE MIX PAN AGITATOR.

If the agitator stops turning during machine operation,

- a. turn off the machine
- b. reposition the agitator with a sanitized utensil - see sanitizing instructions for sanitizing procedure
- c. follow the instructions for starting the machine.

Helpful Hints

Front Plate: This component is the plastic device from which the product is dispensed. It is designed and manufactured for strength and durability. However, through improper use, the front plate can be damaged. Use the following information for proper care:

- a. Do not over tighten the knobs.
- b. Always tighten knobs evenly. Do not attempt to turn one knob all the way down and then one of the other three knobs. Doing so will bind the front plate and could result in breakage.
- c. Improper installation of the stator rods can cause breakage. The stator rods must be properly seated in the dasher before installing the front plate. If the stator rods are improperly installed, subsequent tightening of the knobs will break the front plate.
- d. **DO NOT** attempt to wash the front plate or any other components in a dishwasher.

Mix Out Light: When the mix out light comes on, the mix pan is low on mix. The mix pan must be filled with fresh product mix immediately to prevent air from entering the freezing cylinder starving the machine and causing freeze-up and vibration. If this condition occurs, set the selector switch to the “OFF” position. Remove the carburetor tube and add mix to the low mix pan until the freezing cylinder stops bubbling. Replace the carburetor tube with a gentle twist, then return the control switch to the “AUTO” position.

Filling: Always fill the machine with fresh product at the start of each day.

Drip Tray: This should be removed daily and cleaned to remove residue.

Mix Pan Lid: Be certain to leave the lid in place on top of the machine to prevent any foreign materials from contaminating the mix.

Mixing: Make certain that the product mix is prepared according to label instructions.

Sanitizing: Do not soak plastic parts in sanitizer overnight. Doing so can cause the plastic parts to become brittle and lead to premature failure.

Mix Pan Agitator: If the mix pan agitator stops turning during operation of the machine, turn off the machine, reposition the agitator with a sanitized utensil, and follow the instructions for starting the machine.

DO NOT POUR SOFT SERVE MIX DIRECTLY ONTO THE AGITATOR WHEN YOU FILL THE MACHINE.

Treat the mix pan agitators as any other small parts such as the scraper blades. Follow the same cleaning and sanitizing instructions.

Winter Storage: To protect the unit during seasonal shut-down, it is important that the dispenser be stored in the proper manner. Use the following procedures:

1. Turn off **ALL** power to the machine.
2. Wash all parts that come in contact with the mix with a warm mild detergent solution. Rinse in clear water and dry parts thoroughly.
3. Store the loose parts such as the mix pan components, front plate parts, and the dasher assembly parts outside of the machine.
4. Do not lay heavy objects on the plastic or rubber parts.
5. Cover the machine and all loose parts to protect them from dust or other contaminants while in storage. Place the machine in a dry location.
6. **On water-cooled units, disconnect the water lines. Use compressed air to blow out all remaining water in the condenser. Insert a screwdriver (Fig. 27) to open the water valve. Note: Failure to purge the machine of water can result in severe damage to the cooling system. This task should be performed by a qualified service technician.**

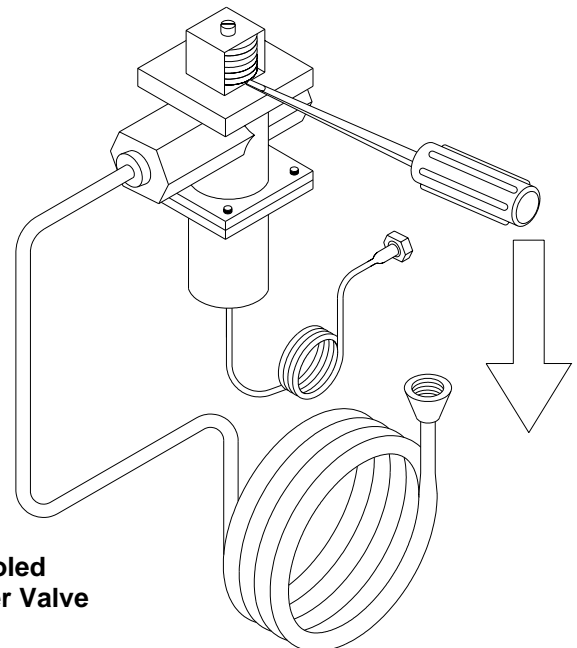
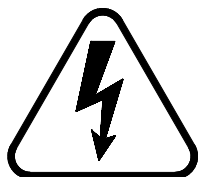


Fig. 27
Water-Cooled
Condenser Valve

Consistency Adjustment

Your SaniServ unit is equipped with either an Electronic or Mechanical Consistency Control System. Use the following information that pertains to your particular machine to adjust the consistency of the product.



SEVERE
ELECTRICAL
SHOCK HAZARD



WARNING

USE EXTREME CAUTION. ELECTRICAL SHOCK HAZARD EXISTS EVEN WHEN THE UNIT IS IN THE "OFF" POSITION. DISCONNECT THE MACHINE FROM ALL OF ITS POWER SOURCES BEFORE PERFORMING ADJUSTMENTS ON THE MACHINE. PERSONAL INJURY OR DAMAGE TO THE MACHINE COULD RESULT IF THIS PRECAUTION IS NOT OBSERVED. ALL PANELS SHOULD BE REPLACED AND ALL POWER SOURCES SHOULD BE RESTORED BETWEEN EACH CONSISTENCY ADJUSTMENT.



HAND PINCH OR
ENTRAPMENT
HAZARD

Mechanical Consistency Control System

Adjustments to the mechanical consistency control system can be made by the owner. Should any problems exist when making adjustments, however, it is strongly recommended that a serviceman trained on SaniServ equipment be contacted. **DO NOT** attempt to make repairs on the machine.

The mechanical control system is a very simple method of controlling the consistency of the finished product. The machine operates without a temperature control. Refrigeration is controlled by measuring the torque on the dasher motor and the consistency of the product. The tension of a spring against the torque idler determines how long the unit will run by activating a limit switch which turns the compressor on and off. The longer the compressor runs, the harder the product. The less it runs, the softer the product. This directly relates to product temperature.

Initial adjustments have been performed at the factory. However, to satisfy individual preferences, the following adjustments may be required:

1. Remove the right side panel as viewed from the front of the machine.
2. Using a regular straight screwdriver, turn the mechanical consistency or torque adjustment screw (Fig. 28) clockwise to make the product harder and counterclockwise to make the product softer. Do not adjust more than two turns each time. **Do not** attempt to adjust the belt idler screw on the left side of the machine marked "**Do Not Adjust**".



WARNING

EXTREME CARE SHOULD BE EXERCISED TO KEEP HANDS AND TOOLS AWAY FROM MOVING PARTS. PERSONAL INJURY COULD RESULT.

3. Replace panels, restore power, wait until the compressor cycles off, then check the consistency of the product.
4. Repeat steps 2 and 3 until the desired product consistency is obtained.

5. Install the right side panel, and the machine is ready for continuous operation.

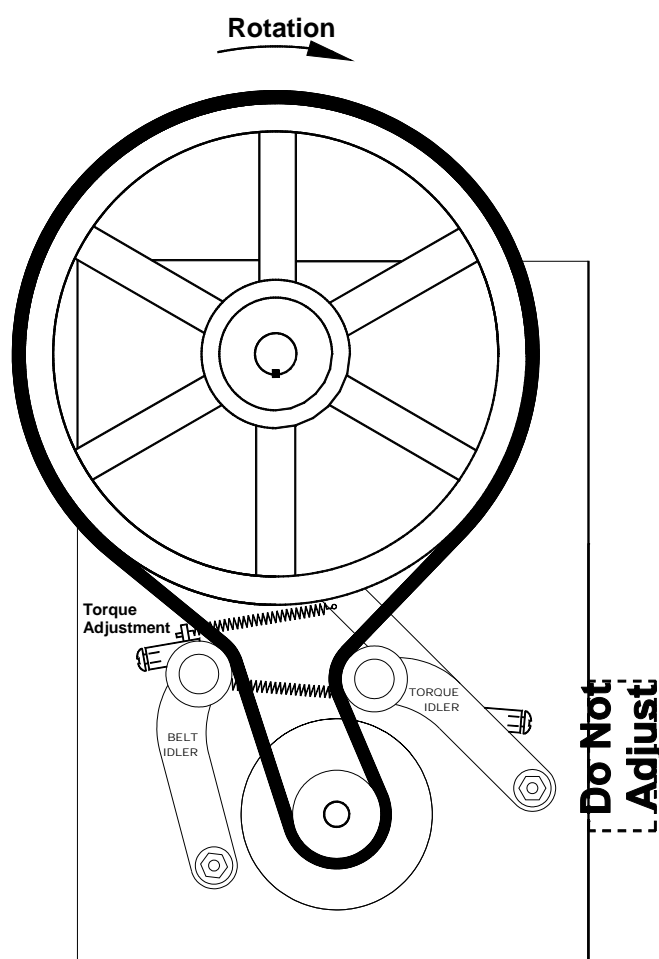


Fig. 28
Mechanical
Consistency Control

NOTE: If product does not freeze to a hard enough consistency, the problem may not be in the machine. To verify, use a standard thermometer to obtain the temperature of the product. The problem is **NOT** in the machine if the temperature is between 17° and 22° F. Check to see that the product mix was prepared to the manufacturer's recommendation.

Electronic Consistency Control System

Adjustments to the Electronic Consistency Control System can be made by the owner. Should any problems arise when making adjustments, SaniServ recommends that a serviceman trained on SaniServ equipment be contacted. DO NOT attempt to make repairs on the machine.



Initial adjustments have been performed at the factory. However, to satisfy individual preferences the following adjustments may be required:

WARNING

USE EXTREME CAUTION. ELECTRICAL SHOCK HAZARD EXISTS EVEN WHEN THE UNIT IS IN THE "OFF" POSITION. WHEN THE WIRING BOX COVER IS REMOVED, DO NOT TOUCH ANYTHING IN THE WIRING BOX EXCEPT THE POTENTIOMETER.

1. Remove the wiring box cover (Exploded View).
2. Set the control switch to the "AUTO" position.
Note: The unit will not operate if the mix pan is empty.
3. Locate the three LED's - green, yellow, and red - Fig. 29. These are used as a reference point to adjust for proper consistency. Initially, all of the LED's are off. This indicates that the mix is too thin. The compressor will now come on. As the product thickens, the green, then the yellow, then the red LED illuminate. Two seconds after the red LED is illuminated, the compressor and dasher will shut off.

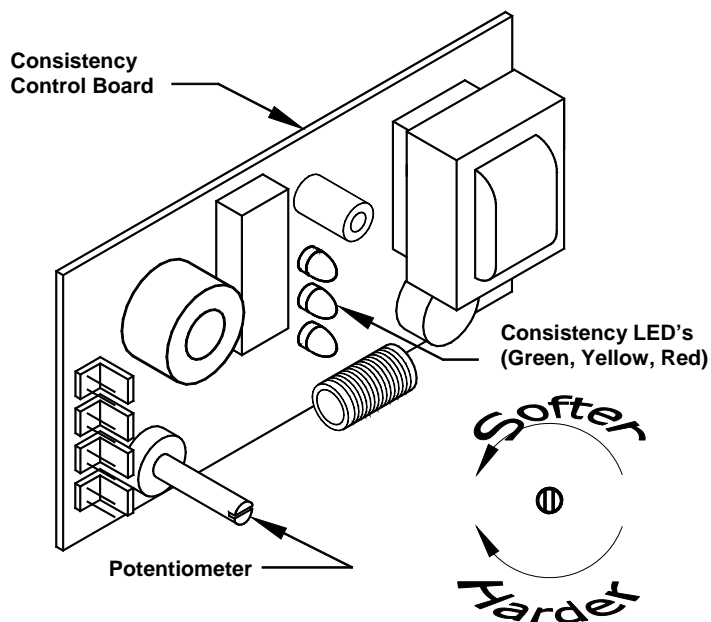


Fig. 29
Electronic Consistency Control

4. Using a small slotted and **insulated** screwdriver, turn the potentiometer (Fig. 29) clockwise to make the product harder or counterclockwise to make the product softer. **Note: The potentiometer is very sensitive. Adjust in small increments**

5. Let the compressor and dasher cycle off. Dispense some product. If too thin, turn **the potentiometer clockwise.**

6. If the product is too thick, **turn the potentiometer counterclockwise.** Dispense 16 oz. (8 oz. on model 407) from the barrel. Let the compressor and dasher cycle off

7. Repeat procedure until proper consistency is achieved.

IMPORTANT

Electronic Consistency Control Operation

1. "CLEANOUT" Position: The dasher motor operates continuously, the compressor will not come on. The mix out probe activates the mix out light but will not activate the buzzer.
2. "AUTO" Position: When product is dispensed, the dasher motor will automatically come on and the compressor will run as required by the consistency of the product. The machine will remain running until the product has reached proper consistency, at which time the dasher motor and compressor will stop running. If product has not been dispensed for approximately 10 minutes, the dasher motor will come on and the control board will sense the product consistency. The compressor will come on if required to maintain product consistency. If the product is correct, the dasher motor will stop.

When product mix is low in the mix pan, the "mix out" light will flash and the buzzer will beep for three minutes or until the mix pan is filled. If the pan has not been filled by the end of the three minute period, the mix out light will glow continuously, the beeping will become a continuous tone, and the machine will not dispense product until mix is added.

NOTE: If product does not freeze to a hard enough consistency, the problem may not be that of the machine. To verify, use a standard thermometer to obtain the temperature of the product.

The problem is not in your machine if the product temperature is between 17° and 22° F. Check to see that the product was prepared to the manufacturer's recommendations.

Routine Maintenance (Owner-Operator)



WARNING

DISCONNECT THE MACHINE FROM ITS POWER SOURCE(S) BEFORE PERFORMING ANY ROUTINE MAINTENANCE. PERSONAL INJURY OR DAMAGE TO THE MACHINE COULD RESULT IF THIS PRACTICE IS NOT OBSERVED.

Daily: Inspect the machine for signs of product leaks past seals and gaskets. If proper assembly does not stop leaks around gaskets or seals, check for improper lubrication and worn or damaged parts. Replace parts as needed.

Periodically: Inspect the scraper blades (Fig. 30) to see that they are straight and sharp. If worn, damaged or warped, the blades will not scrape the cylinder walls correctly and the freezing capacity will be reduced. Clean the drip chute assembly (Fig. 31) with warm water and detergent solution.

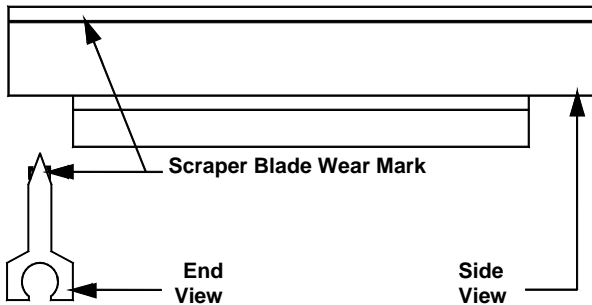


Fig. 30
Scraper Blade Wear Mark

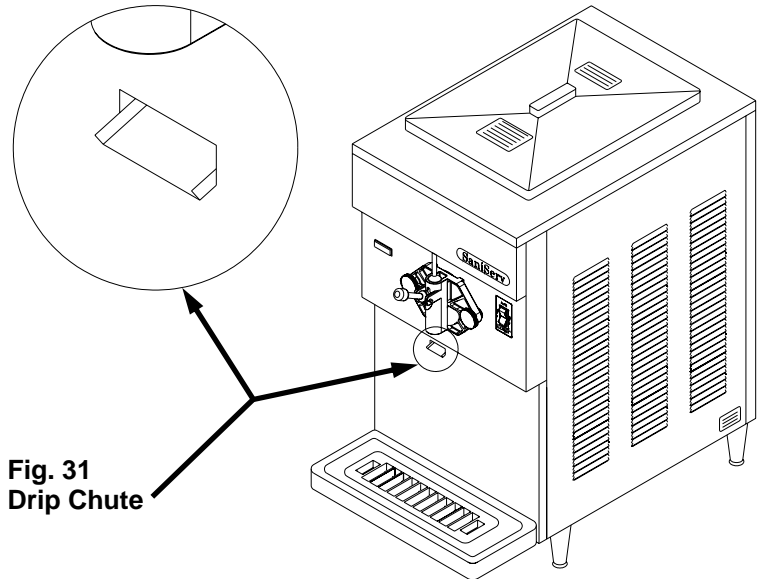
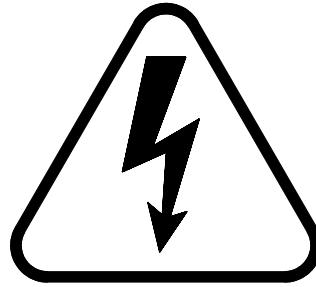


Fig. 31
Drip Chute



Routine Maintenance (Trained Service Technician)



WARNING

**CONDENSER FINS ARE VERY SHARP
USE EXTREME CAUTION WHEN CLEANING**

Quarterly: Thoroughly clean the condenser fins on all air-cooled machines. Remove all lint and dust with a vacuum cleaner or compressed air (Fig. 32) to clean fins. A dirty condenser greatly reduces refrigeration capacity and efficiency. When using compressed air, place a damp cloth on the opposite side of the condenser to catch the flying dirt or lint.

Annually: Check the belts for signs of wear or cracking. Remove panels and clean all parts inside of the machine including the base, side panels, fan blades, condensers, etc.



Fig. 32
Clean Sharp Condenser Fins



Routine Maintenance (Trained Service Technician)



WARNING

HAZARDOUS MOVING PARTS

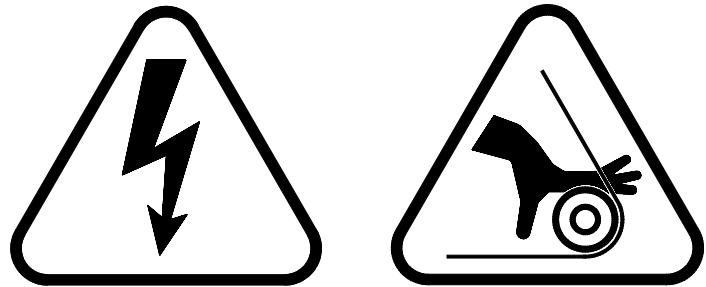
Semiannually: It is advisable to clean and lubricate the idler arms (Fig. 33) to ensure their smooth operation. Use the following procedures:

1. Make certain that **ALL** power to the dispenser is off.
2. Remove both side panels first, then remove the rear panel of the machine.
3. Use a pencil to mark the position of the nut (Fig 33) on the side of the belt idler arm spring adjustment mechanism. Relieve the tension on the spring by turning the adjustment screw near the label which warns: **DO NOT ADJUST**. Disconnect the spring from the belt idler arm by placing needle nose pliers on one end of the spring and pulling the end out of the retainer.
4. Remove the nut, bolt, sleeve and idler arm from the pivot point of the belt idler arm assembly.
5. Remove the belt idler arm and inspect the pivot point sleeve. These areas should be free of rust, debris, or dried lubricant. If any of these substances are found, they must be removed.
6. Clean and polish the sleeve surface with a fine grade of emery cloth and apply anti-seize compound.
7. Reinstall the belt idler arm.
DO NOT OVERTIGHTEN THE LOCKING NUT. ON

CAUTION

SOME UNITS IT IS POSSIBLE TO OVERTIGHTEN THE LOCKING NUT AND CAUSE THE IDLER ARMS TO BIND. THE ARMS SHOULD MOVE FREELY.

8. Repeat the process for the torque idler arm.
9. Install the belt making certain that there is no grease on the belt or pulleys. Step to the side of the unit and view the belt to determine whether or not it is properly aligned (straight from top to bottom).
10. Reinstall the torque idler arm spring and the belt idler arm spring and turn the adjustment screws returning the adjustment nuts to the pencil marks you placed on the side of each adjustment mechanism in step 3 above.



11. Repeat steps 3 - 9 for the other side if your machine has two freezing cylinders and then place the unit back into operation. Check the product for proper consistency and adjust as required. When the consistency is right, replace the rear and both side panels.

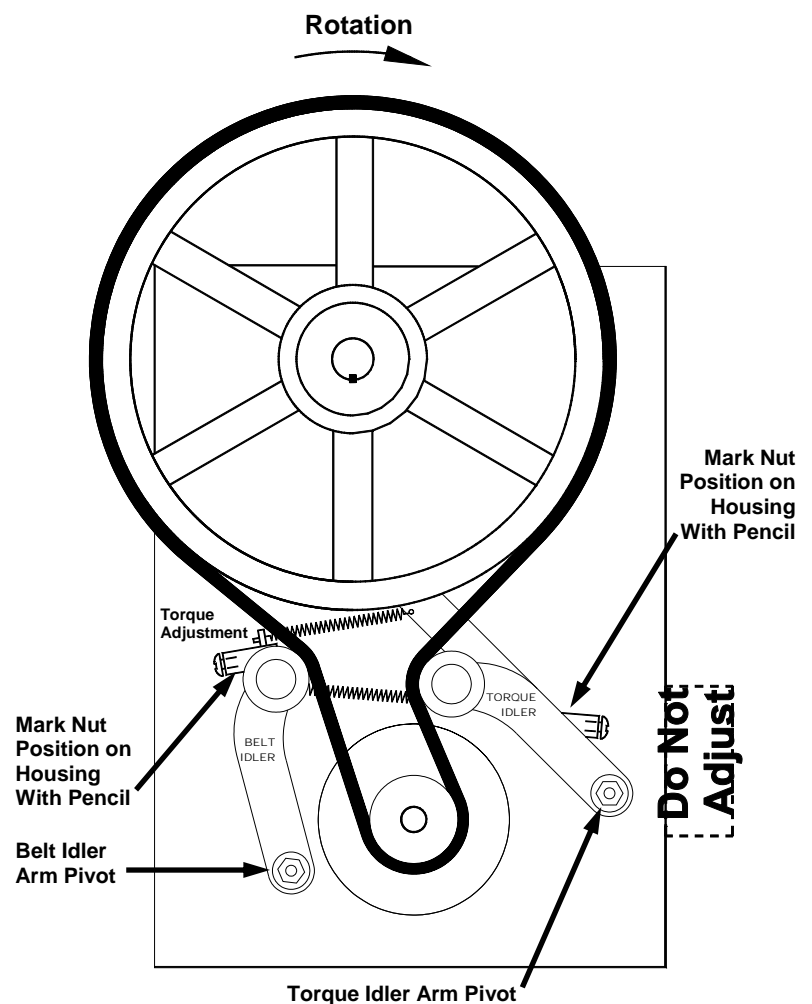


Fig. 33
Torque Spring Adjustment Mechanism

Please make these simple checks prior to contacting your service provider. Because adjustments to the machine are not covered under the terms of warranty, these tips can save you time and money. If you feel you are not comfortable performing trouble-shooting suggestions, please contact your local certified service provider.

| | |
|--|---|
| Machine will not start | <ul style="list-style-type: none"> ✓ Make sure electrical cord is correctly seated in the electrical receptacle. ✓ Check circuit breaker in electrical panel. |
| Product is Soft | <ul style="list-style-type: none"> ✓ Do not make a consistency adjustment at this point. Always check product temperature first. Should be between 18-21 degrees soft serve, 17-20 degree's yogurt, 25-28 degrees shake. If using a soft serve product and temperature is lower than listed, product is broken down. See Product Breakdown in glossary section. Replace with fresh product. ✓ Check for properly mixed product. Replace as necessary ✓ If using Re-run product, remove product and add fresh mix. ✓ Confirm that the carbtube has been installed. Product will not thicken without carbtube. ✓ Check for dull scraper blades. Blades should be sharp. Replace every 6 months. ✓ Check Condenser for dirt or obstructions. See Quarterly Maintenance ✓ Confirm that the condenser fan is running. ✓ Confirm 6" of airflow on all both sides and back of machine. ✓ High ambient temperature. Recommended machine ambient temperature not to exceed 82 degrees. |
| Product is too Thick | <ul style="list-style-type: none"> ✓ Check for properly mixed product. ✓ Confirm freezing cylinder is not starved of product. See glossary (Starved Cylinder) ✓ Check product temperature. Should be between 18-21 degrees soft serve, 17-20 degree's yogurt, 25-28 degrees shake. ✓ Check for missing scraper blade or stator rod. Check dasher assemblies. ✓ Check for sticking spigot lever and or switch. If stuck in the up position, will cause unit to run continually. |
| Front Plate Leaking | <ul style="list-style-type: none"> ✓ Confirm front plate o-ring is not ripped or torn. Replace if necessary. Replace seals and o-rings every six months. ✓ Do not lubricate front plate o-ring. ✓ Confirm spigot plunger o-rings are not ripped or torn. Replace if necessary. Replace every six months. ✓ Confirm spigot plunger o-rings are lubricated daily. ✓ Tighten front plate knobs evenly. ✓ Confirm stator rod is not worn or grooved. |
| Product leaking from the drip chute and or drip tube. | <ul style="list-style-type: none"> ✓ Rear Seal is worn. Replace. Note: Replace seals, o-rings and gaskets every six months. ✓ Do Not Lubricate the rubber portion of the rear seal ✓ The shaft of the dasher where the rear seal is installed must be lubricated daily. ✓ Confirm stator rod is not worn or grooved. ✓ Front plate knobs loose. |
| Squeaking , chirping noises and or vibration heard. | <ul style="list-style-type: none"> ✓ Use properly mixed product. Replace as necessary. ✓ Confirm freezing cylinder is not starved of product. See glossary (Starved Cylinder) ✓ Check lubrication ✓ Confirm all panel screws are installed and tightened ✓ Adjust width of drip tray bracket. ✓ Check for dull scraper blades. Blades should be sharp. Replace every 6 months. |
| Product in mix-pan too warm. (soft serve /shake machines) | <ul style="list-style-type: none"> ✓ Refrigerate product prior to use. ✓ Confirm storage source of product at 40 degrees or below. ✓ Maintain product level of ½ to ¾ full in mix-pan reservoir. ✓ Confirm magnetic agitator is installed and turning. ✓ Mix-pan lid must be installed at all times to prevent foreign materials contaminating product and to insulate product in the mix-pan . |
| Who to contact for service and parts | <ul style="list-style-type: none"> ✓ If you do not have a local service and parts provider, contact your SaniServ Dealer/Distributor. Visit www.saniserv.com to locate a Distributor (Sales Section) or a Service Agent (Technical Support Section). |

Note: Refer to glossary for those items selected in bold.

Trouble Shooting Glossary

Ambient Temperature. The temperature of the air in the immediate vicinity of the operating machine. High ambient temperature can reduce the capacity with an air-cooled condenser.

Capacity. The total capacity of frozen product that a freezer can produce in a given period usually stated in gallons per hour (G.P.H.).

Carbtube. Flow control device that allows product and air to be blended together. The air added to the product is labeled as over-run. The over-run helps provide a thick and rich product. If the carbtube is not used the product will be heavy, wet, grainy, will not thicken and product temperatures will be lower than the specified 18-21 degrees soft serve and 25-28 degrees shake.

Condenser. The part of the refrigeration mechanism that receives hot, high-pressure refrigeration gas from the compressor and cools gaseous refrigerant until it returns to a liquid state.

Consistency. The viscosity or thickness of the product in the freezing cylinder.

Consistency Control. A control that senses the thickness or viscosity of the product in the freezing cylinder.

Dasher. The part of the freezer that scrapes frozen product off the inside of the freezing cylinder and blends the product. In a gravity freezer, this assembly also moves the product forward to be dispensed.

Front Plate. Seals the front of the freezing cylinder and provides a means for dispensing the product. On gravity fed freezers, the front plate indirectly holds the dasher in place via the stator rod. It also provides compression for the rear seal.

Freezing Cylinder. The part of the refrigeration mechanism in which the refrigerant vaporizes and absorbs heat. This is the part of the freezer where the liquid product is frozen.

Magnetic Agitator. Installed in the mix-pan reservoir and used to maintain product temperatures and prevent product separation. The bottom of the agitator must be lubricated.

Mix-pan. Is the top container that product is poured into. It is used as storage until product is needed for the freezing cylinder. Soft Serve and Shake machines have refrigerated mix-pans to prevent bacteria from forming.

Mixing Product / Product Temperatures. If your using a product that has to be mixed with water or other ingredients, it is imperative the product is mixed consistently everyday. If not, the machine will not run consistent and could possibly damage components. This is very important with frozen (slush) beverages. Always mix to the product manufactures recommendations. The machine is designed to operate with a frozen product that falls within these temperatures (soft serve 18-21 degrees, yogurt 17-20 degrees, shake 25-28 degrees).

Overrun. The volumetric increase of product from the liquid to the solid state due to the incorporation of air into the frozen product. Overrun is states as a percentage.

Product Breakdown. The decline in frozen product quality resulting from excess agitation or temperature variations of product that has been in the freezing cylinder too long. Product, which has broken down, may be grainy, wet and or heavy. Product breakdown is easily detected by taking the temperature of the dispensed product. Temperatures will always be lower than recommended product temperatures.

Trouble Shooting Glossary

Rear Seal. This part is stationary during operation and must not move. When installed and lubed properly, seals mix in cylinder. When installed and lubed improperly, it causes main shafted bearing failure.

Rerun. The reuse of previously frozen product after it has melted to a liquid. Rerun is obtained when emptying a freezer for periodic cleaning. Use caution when using rerun as it may contain high bacteria or Coli count, which could contaminate the fresh mix with which it is combined. Freezers should never be started with rerun. If used at all, it should be blended with fresh mix at a ratio of seven parts new mix with three parts old mix, after initial freeze-down with fresh mix.

Scraper Blades. The component that scrapes the frozen product from the freezing cylinder surface. Blades must be sharp, as dull blades will leave product on the freezing cylinder, insulating the mix from the refrigerant.

Spinner Assembly. An externally installed or internally installed component used to blend a base product with flavoring or other particulate.

Spigot Plunger. The mechanism on the front plate through which the product is dispensed.

Starved Cylinder. A starved cylinder is often mistaken for a freeze up or product too thick. A starved cylinder (starving) is created when a larger percentage of frozen product is dispensed from the freezing cylinder than the percentage of liquid product entering the freezing cylinder from the mix-pan. There are several causes of starving.

1. **Overdrawing:** Dispensing more product from the machine than it's designed to do. This would occur if a machine were undersized for its application.
2. Inserting the carbtube prior to pouring the initial product into the mix-pan at the start of each day. This forms a vacuum and traps a large percentage of air in the cylinder; therefore the cylinder will not fill with product.
3. When carbtube hole setting is not set on the correct hole size for the amount of product being drawn. Example, if several customer dispense product from the machine with the carbtube set on the small hole, it will not allow the freezing cylinder to be replenished with product in a timely manner. Change carbtube setting to a larger hole.
4. Carbtube not being cleaned, thus allowing product build-up in the carbtube holes. This restricts product from entering the freezing cylinder.
5. Mix out light not working therefore not alerting operator the need to add product.
6. Pouring frozen or semi frozen product into the mix-pan reservoir. This will form a blockage in the carbtube hole and not allow liquid product to flow into the cylinder.
7. Mix-pan too cold, allowing product to freeze in mix-pan and restricting product flow.

Stator Rod. Acts as a bearing surface. Helps enfold air for overrun. Transmits compression to the rear seal. Helps mechanical torque system sense torque. Be sure to lubricate.

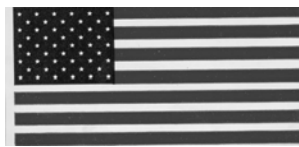
This page intentionally blank.

SaniServ®

 An AFFINIS GROUP Company

451 E. County Line Road
P.O. Box 1089
Mooresville, Indiana 46158-5089

We are on the web...
www.saniserv.com



Proudly made in the U.S.A.

Technical Publication
Publ. No. 80975
Updated 08/07