

OPERATOR'S & MAINTENANCE MANUAL

Haulotte 
GROUP

4527A / HTA 16 P

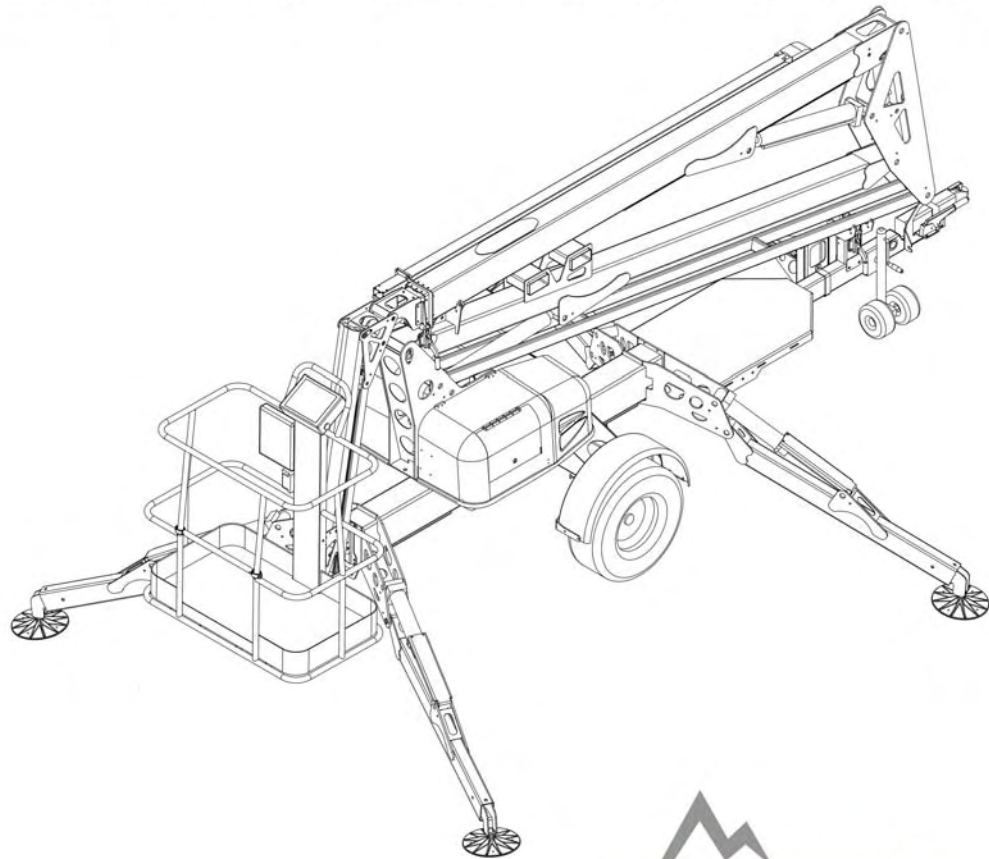

 **SUMMIT**SERIES
TRAILER-MOUNTED BOOMS™

B33-01-0095

AERIAL WORK PLATFORM

This equipment is designed and manufactured in compliance with the duties, responsibilities and standards set forth for manufacturers in the ANSI, CSA, AS and / or CE standards in effect at the time of manufacture.

This equipment meets or exceeds applicable ANSI, CSA, AS and / or CE codes and standards when operated in accordance with manufacturer's recommendations.

It is the responsibility of the user to follow all Federal, State, and Local codes and regulations that govern the safe operation of this equipment.

Obtain, read and obey all safety precautions before performing maintenance or repairs or attempting to operate this equipment. This includes all manufacturer recommendations as well as all Federal, State, and Local codes and regulations.

To ensure proper and safe use of this equipment, it is strongly recommended that only trained and authorized personnel attempt to operate and maintain the aerial work platform.

This manual shall be considered a permanent and necessary component of the aerial work platform and shall be kept with the machine at all times.

Owners and Lessors should complete a full inspection of all components and perform a test of all functions, including brake functions, before commissioning or reselling the aerial work platform. Repair or replace all damaged or malfunctioning components.

Haulotte Group is dedicated to the continuous improvement of this and all Haulotte Group products. Therefore, equipment information is subject to change without notice. Direct any questions or concerns regarding errors and / or discrepancies in this manual to the Haulotte Group Customer Service Department: at 1-800-537-0540 or visit Haulotte Group online at www.haulotte-usa.com.

CALIFORNIA

Proposition 65 Warning

Diesel engine exhaust and some of its constituents are known to the State of California to cause cancer, birth defects, and other reproductive harm.

TABLE OF CONTENTS

1	SAFETY	7
	LEGEND: SAFETY ADVISORIES.....	7
	BEFORE OPERATION.....	8
	DURING OPERATION	9
	FALL PROTECTION	11
	MANUAL FORCE	11
	WIND LOADING.....	12
	EXPLOSION HAZARD	12
	MAINTENANCE	13
2	SPECIFICATIONS	15
	RANGE OF MOTION	15
	SPECIFICATIONS.....	16
	WARRANTY - NEW PRODUCT; HAULOTTE NORTH AMERICA.....	18
	WARRANTY CLAIMS PROCEDURE.....	19
	DAMAGED EQUIPMENT POLICY.....	20
3	OPERATION	21
	GROUND (LOWER) CONTROL PANEL.....	22
	PLATFORM (UPPER) CONTROL PANEL.....	24
	NORMAL OPERATING PROCEDURE	26
	MANUAL BOOM OPERATION	29
	TOWING THE AERIAL WORK PLATFORM.....	31
	LIFTING THE AERIAL WORK PLATFORM.....	33
	TRANSPORTING THE AERIAL WORK PLATFORM ON A TRUCK BED.....	34
4	EQUIPMENT MAINTENANCE	35
	BATTERY RECHARGE.....	36
	BATTERY FAULT CODES.....	37
	DAILY SERVICE CHECKS	38
	WEEKLY SERVICE CHECKS.....	41
	MONTHLY SERVICE CHECKS	42
	ANNUAL SERVICE CHECKS	43
	STRUCTURAL INSPECTION	45
	MOTOR DRYING INSTRUCTIONS	45
	LEVELING SYSTEM CALIBRATION PROCEDURE	46
	OVERLOAD PROTECTION CALIBRATION PROCEDURE	48
	ADDITIONAL SERVICE INFORMATION	50
	TROUBLESHOOTING	51
	ERROR CODE DEFINITIONS – CONTROLS	52
	ERROR CODE DEFINITIONS – MOTOR CONTROLLER	63
5	CYLINDER REPLACEMENT	65
	MASTER / SLAVE CYLINDER REPLACEMENT	65
	LIFT CYLINDER REPLACEMENT	67
	OUTRIGGER CYLINDER REPLACEMENT.....	69
6	DECAL REPLACEMENT	71
	DECAL KIT - ANSI	72
	IDENTIFICATION PLATES & OPTIONAL EQUIPMENT - ANSI.....	74
	DECALS - ANSI.....	76
	DECAL KIT - CE.....	80
	IDENTIFICATION PLATES & OPTIONAL EQUIPMENT - CE.....	82
	DECAL KIT - AU.....	84

7	OPTIONAL EQUIPMENT	89
	DRIVE AND SET	90
	MATERIAL LIFT HOOK	93
	MANUAL PLATFORM ROTATOR	96
8	MATERIAL SAFETY	97
9	AXLE AND RELATED COMPONENTS	107
9A	DEXTER AXLE AND RELATED COMPONENTS	107
	SET UP AND ADJUSTMENT	107
	HOW TO USE YOUR ELECTRIC BRAKES PROPERLY	111
	MAINTENANCE	112
	STORAGE	124
	TROUBLE SHOOTING	126
9B	BRADLEY BRAKE ADJUSTMENT	130
	AERIAL WORK PLATFORMS WITH STANDARD BRAKES	130
	THIRTEEN PERCENT (13 %) GRADE TEST	131
	AERIAL WORK PLATFORMS WITH DRIVE AND SET BRAKES	132
	TROUBLESHOOTING THE BRADLEY RUNNING GEAR	133
10	ANSI REPRINT	135
	INSPECTION FORM FOR HAULOTTE AERIAL WORK PLATFORMS	143

LIST OF TABLES

TABLE 1-1.	MINIMUM SAFE APPROACH DISTANCES	9
TABLE 1-2.	BEAUFORT SCALE	12
TABLE 4-1.	BATTERY CHARGER FAULT CODES	37
TABLE 4-2.	TROUBLE SHOOTING	51
TABLE 4-3.	ERROR CODE DEFINITIONS	52
TABLE 4-4.	ERROR CODE DEFINITIONS - MOTOR CONTROLLER	63
TABLE 9-1.	WHEEL TORQUE REQUIREMENTS	110
TABLE 9-2.	TRAILER WIRE SIZE CHART	111
TABLE 9-3.	MAINTENANCE SCHEDULE	112
TABLE 9-4.	RECOMMENDED WHEEL BEARING LUBRICATION SPECIFICATIONS ...	118
TABLE 9-5.	TIRE WEAR DIAGNOSTIC CHART	122
TABLE 9-6.	MAGNET AMPERES CHART	123
TABLE 9-7.	TROUBLESHOOTING – HYDRAULIC BRAKING SYSTEM	127
TABLE 9-8.	TROUBLESHOOTING - ELECTRIC BRAKING SYSTEM	129
TABLE 10-1.	MINIMUM SAFE APPROACH DISTANCES	141

LIST OF ILLUSTRATIONS

Figure 2-1. Range of Motion	15
Figure 3-1. Ground (Lower) Control Panel	22
Figure 3-2. Platform (Upper) Control Panel	24
Figure 3-3. Boom Travel Latches	26
Figure 3-4. Outrigger Control Panel.....	27
Figure 3-5. Hand Pump Controls for Manual Operation	29
Figure 3-6. Location of Lift Cylinders	30
Figure 3-7. Location of Manual Lowering Valves.....	30
Figure 3-8. Trailer Hitching	32
Figure 3-9. Lifting the Aerial Work Platform	33
Figure 3-10. Transporting the Aerial Work Platform	34
Figure 4-1. Battery Charger Faceplate	36
Figure 4-2. Outrigger Position Switch	39
Figure 4-3. Hydraulic Reservoir	40
Figure 4-4. Wheel Nut Tightening Sequence.....	42
Figure 4-5. Display Run Time Hours	43
Figure 4-6. Machine Position for Slew Ring Measurement.....	44
Figure 4-7. Slew Ring Position Measurement	44
Figure 4-8. Platform Position after Rotation.....	44
Figure 4-9. Position Machine for Leveling	46
Figure 4-10. Level Sensor	46
Figure 4-11. Level Sensor	46
Figure 4-12. Ground (Lower) Control Panel for Leveling System.....	47
Figure 4-13. Platform Position	48
Figure 4-14. Ground (Lower) Control Panel for Overload Protection.....	48
Figure 4-15. Motor Controller.....	63
Figure 5-1. Location of Master Cylinder.....	65
Figure 5-2. Location of Slave Cylinder.....	66
Figure 5-3. Location of Manual Lowering Valves.....	67
Figure 5-4. Push “Button” Lowering Valve	67
Figure 5-5. Lift Cylinder Replacement	67
Figure 5-6. Outrigger Cylinder Replacement	69
Figure 5-7. Cylinder Valve Removal	69
Figure 7-1. Drive and Set Controls	90
Figure 7-2. Disconnect Plug from Load Sense Module	93
Figure 7-3. Remove Platform (Upper) Control Box.....	93
Figure 7-4. Loopback plug.....	93
Figure 7-5. Platform Removal.....	94
Figure 7-6. Material Lifting Hook Installation	94
Figure 7-7. Material Lift “Stowed” Position.....	95
Figure 7-8. Material Lift “In Use” Position	95
Figure 7-9. Manual Platform Rotator	96
Figure 9-1. Standard Brake Adjustment Procedure	130
Figure 9-2. Drive & Set Brake Adjustment Procedure	132
Figure 10-1. Minimum Safe Approach Distance	140

PRIMARY MACHINE COMPONENTS

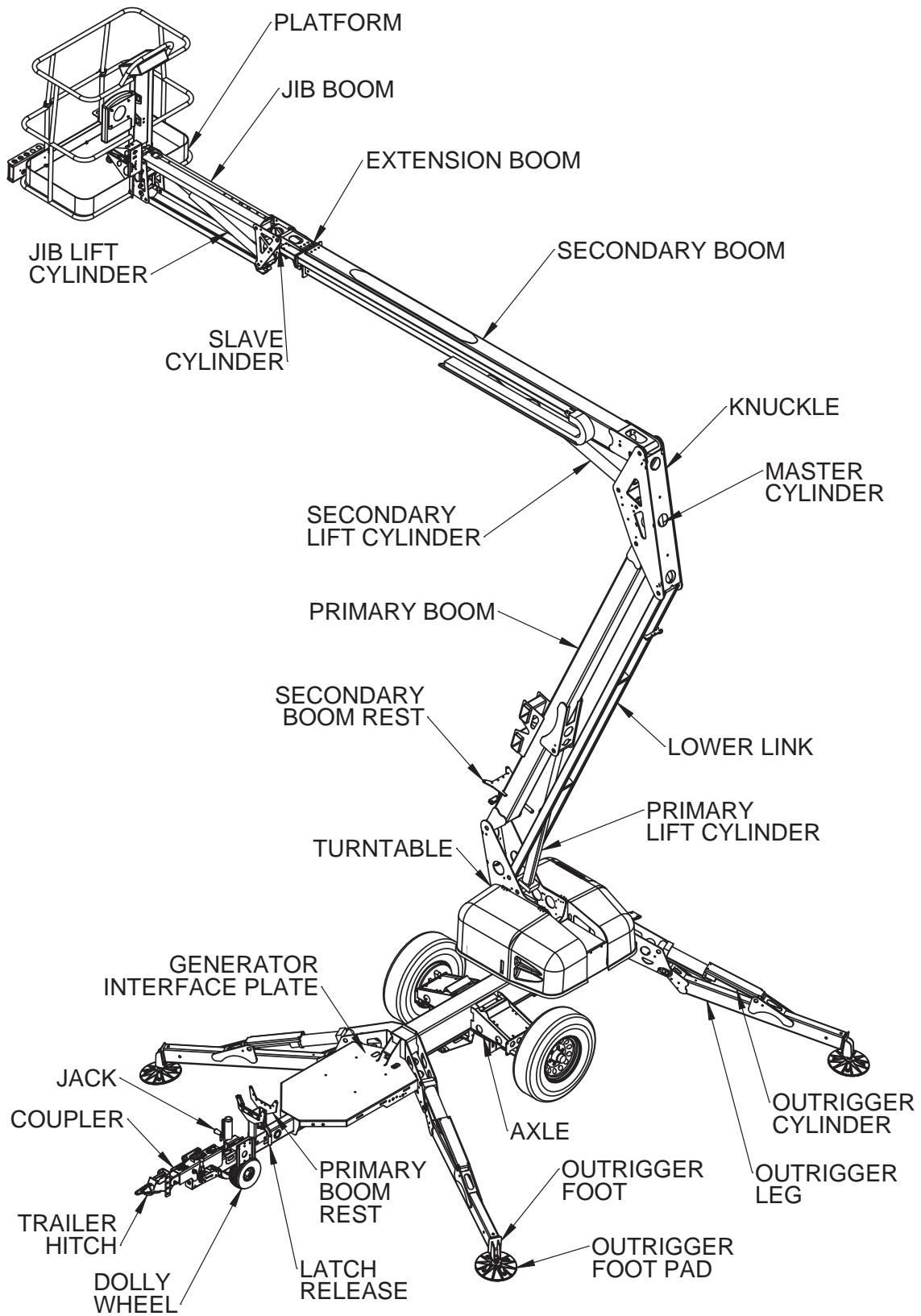

1 SAFETY

Proper training is required for the safe operation of any mechanical device. Failure to follow all instructions and safety precautions in this manual and attached to the aerial work platform will result in death or personal injury.

Prior to Operation:

- Read, understand and obey all instructions and safety precautions in this manual and attached to the aerial work platform.
- Read, understand and obey all Federal, State and Local codes and regulations.
- Become familiar with the proper use of all controls.
- Inexperienced users should receive instruction by a qualified instructor before attempting to operate or maintain the aerial work platform.

The use of intelligence and common sense is the best practice when following any safety policy.

LEGEND: SAFETY ADVISORIES

The following safety advisories are used throughout this manual to indicate specific hazards when operating or maintaining the aerial work platform. Read, understand and obey all safety advisories to prevent improper service, damage to equipment, personal injury or death.



DANGER

Indicates a hazardous situation which if not avoided, will result in death or serious injury.



WARNING

Indicates a hazardous situation which if not avoided, could result in death or serious injury.



CAUTION

Indicates a hazardous situation which, if not avoided, may result in minor or moderate injury.

NOTICE

Contains information important in the prevention of errors that could damage the machine or its components.

NOTE: Contains additional information important for performing a procedure.

BEFORE OPERATION

Ensure the following general safety precautions are followed before operating the aerial work platform:

ALWAYS inspect the usage area for potential hazards, such as unstable or unlevel surfaces, overhead obstructions and electrically charged wires or conductors. **ALWAYS** watch for moving vehicles in the operating area.

ALWAYS conduct a thorough visual inspection of the aerial work platform before operation. Check for damaged or worn parts, hydraulic leaks, damaged wiring, loose wiring conductors, damaged outriggers, low tire pressure, uneven tire wear or tire damage. Check for any improperly operating components. **NEVER** operate the aerial work platform if any damage is observed or suspected. Repair damaged or malfunctioning equipment before operation.

ALWAYS wear proper clothing. Wear protective equipment as required by all Federal, State, and Local codes and regulations. Keep loose clothing, jewelry, gloves and hair away from moving parts.

ALWAYS wear a Safety Harness and energy-absorbing Lanyard, such as the Safety Harness and Lanyard available through the Haulotte Group.

ALWAYS inspect platform floor and outrigger footpads for mud, grease, debris or other foreign material. **ALWAYS** remove any such material from the aerial work platform before operation.

ALWAYS RED tag any part of this machine known or suspected to be damaged or malfunctioning. **ALWAYS** remove a malfunctioning, damaged or defective aerial work platform from service. **NEVER** operate an aerial work platform that has any known or suspected defect.

ALWAYS comply with the instructions found in Safety and / or Service Bulletins distributed by the manufacturer / factory. Bulletins may contain critical procedures that supersede the information contained in this manual.

NEVER operate this aerial work platform while under the influence of drugs or alcohol, while taking prescription medications that may leave the operator drowsy or prone to dizziness, or while feeling ill.

NEVER modify, alter or change the aerial work platform in any way that would affect its original design or operation.

NEVER deface, modify or obscure any decals or markings on the aerial work platform.

NEVER operate this aerial work platform in any way for which it is not intended.

NEVER operate this aerial work platform in explosive or flammable environments.

Before attempting aerial work platform operations, operator(s) should:

- Attend a training program as required by all Federal, State, and Local codes and regulations.
- Obtain, read and obey all safety precautions as indicated by manufacturer's recommendations and all Federal, State and Local codes and regulations.
- Become familiar with the location and use of all controls.
- Verify that there are no overhead obstructions or live power sources in the work area that could interfere with the safe operation of the aerial work platform.
- Cordon off the area surrounding the aerial work platform to keep personnel, vehicles and moving equipment away from the aerial work platform while in use.
- Position the aerial work platform on a firm and level surface.
- Conduct a pre-operation inspection by performing all recommended daily service checks. Refer to the "Equipment Maintenance" section of this manual.

DURING OPERATION

Ensure the following general safety precautions are followed while operating the aerial work platform:

ALWAYS position away from power lines, this ensures that no part of the aerial work platform accidentally reaches into an unsafe area. This includes full extension of the telescoping boom through 700° Non-Continuous rotation.

 **DANGER**

This aerial work platform is **NOT** insulated for use near electrical power lines and **DOES NOT** provide protection from contact with or close proximity to any electrically charged conductor. Operator must maintain safe clearances at all times (10 ft (3.05m) minimum) and must always allow for Platform movement due to gusty winds. Always contact power company before working near power lines. Assume every power line is live. Power lines can be blown by the wind.

Refer to Table 1-1 for minimum safe approach distances between the machine and electrical power lines.

TABLE 1-1. MINIMUM SAFE APPROACH DISTANCES		
Voltage Range (Phase to Phase)	Minimum Safe Approach Distance	
	(Feet)	(Meters)
0 to 300V	Avoid Contact	
Over 300V to 50KV	10	3.05
Over 50KV to 200KV	15	4.60
Over 200KV to 350KV	20	6.10
Over 350KV to 500KV	25	7.62
Over 500KV to 750KV	35	10.67
Over 750KV to 1000KV	45	13.72

ALWAYS check with local electrical authorities regarding any local requirements which may differ from those shown in Table 1-1

ALWAYS keep away from an aerial work platform that is exposed to electrically charged power lines. If the aerial work platform comes in contact with electrically charged power lines, **NEVER** touch or operate the aerial work platform until power lines are shut off.

ALWAYS operate only on a firm and level surface. **NEVER** operate on surfaces that do not support the aerial work platform with its rated load capacity, or on surfaces that do not support force exerted by the outriggers during aerial work platform operation. Operate only on surfaces that can support a pressure of 25 psi (1.8 kg/cm²) to ensure safe operation.

ALWAYS keep personnel away from potential pinch and shear points and from potential crush hazards as indicated by decals attached to the aerial work platform.

ALWAYS keep the safety bar lowered (closed) unless personnel are entering or exiting the work platform.

DURING OPERATION (CONTINUED)

ALWAYS use a three (3) point contact (both hands and one foot) when entering or exiting the work platform.

ALWAYS wear proper footwear. **ALWAYS** keep the platform free of debris.

ALWAYS keep personnel and obstructions clear of the aerial work platform when repositioning the boom or platform.

ALWAYS cordon the area surrounding the outriggers to keep personnel, vehicles and moving equipment away from the aerial work platform while in use.

ALWAYS stay clear of overhead obstructions, including wires and cables.

ALWAYS unhitch trailer from tow vehicle before operating outriggers.

NOTICE

Failure to unhitch trailer from tow vehicle prior to outrigger deployment could cause damage to trailer tongue and / or tow vehicle.

ALWAYS disengage aerial work platform travel latches before raising aerial work platform sections and reengage aerial work platform travel latches before towing trailer.

ALWAYS exercise caution when rotating the boom from the ground (lower) control panel. **ALWAYS** watch for personnel inside the radius of the turntable and boom arm when rotating from the ground (lower) or platform (upper) control panels.

ALWAYS remove personnel from the aerial work platform before attempting to free an elevated platform that has become caught or snagged on an adjacent structure or obstacle.

NEVER operate the aerial work platform from a position on a truck-bed, trailer, floating vessel or scaffolding without written approval from the manufacturer / factory.

NEVER operate the Drive function (if equipped) on grades exceeding 4.5°, or with more than one person in the platform.

ALWAYS maintain drive enable button during drive operation.

NEVER allow electrode contact with any part of the aerial work platform while welding from the platform. **NEVER** use the aerial work platform as a ground for welding.

NEVER operate without the outriggers fully extended or when the aerial work platform is not level.

NEVER position an elevated platform against another object to steady the platform.

NEVER override or bypass the manufacturer's safety devices.

NEVER attach a safety harness to an adjacent structure, pole, or to nearby equipment while working from the platform.

NEVER raise the outriggers or move the trailer with materials or personnel on board, or while boom is raised or extended.

NEVER sit, stand or climb on platform railing. **ALWAYS** keep both feet firmly on the platform floor.

NEVER attempt to increase the working height with boxes, ladders, stools or any other materials.

NEVER operate this aerial work platform when exposed to high winds, thunderstorms, ice or any weather conditions that would compromise operator safety.

DURING OPERATION (CONTINUED)

NEVER operate aerial work platform in conditions where wind speeds exceed 28 mph (12.5 m/sec or 45 km/h). Steady or gusty winds that exceed the recommended wind speed may affect stability and aerial work platform operation.

NEVER allow ropes, electric cords, hoses or other equipment to become entangled in the aerial work platform.

NEVER exceed the load limits set by the manufacturer / factory. Use only the material lifting hook, supplied as an option and manufactured by Haulotte Group when lifting materials. Safely stow all tools and equipment.

NEVER exceed load ratings by transferring loads to the aerial work platform at elevated heights.

NEVER use the platform to lift a load that exceeds the platform dimensions. **NEVER** lift a load in such a way that the center of gravity is higher than the top guardrail of the platform.

NEVER modify the platform or carry materials that would increase the surface area of the platform. Increasing the area exposed to the wind may affect the aerial work platform stability. **NEVER** attach overhanging loads when raising or lowering the platform.

NEVER use the boom or platform to push or pull or to lift any part of the trailer.

NEVER use the boom or platform to place a load against any structure, materials or equipment.

NEVER climb on the boom.

NEVER leave an elevated platform unattended.

NEVER leave the keys in the aerial work platform while unattended or not in use.

FALL PROTECTION

- Occupants must wear a safety belt or harness in accordance with all Federal, State, and Local codes and regulations. Attach lanyard to the anchor provided on the work platform.
- **Never** sit, stand, or climb on the platform guard rails. Maintain a firm footing on the platform floor at all times.
- **Never** climb down from the platform when raised. If a power failure should occur, ground personnel should use the manual controls to lower the platform. Refer to the "Operation" section of this manual for manual operation.
- Keep platform floor clear of debris.
- Lower the platform entry mid-rail or close the entry gate before operating.

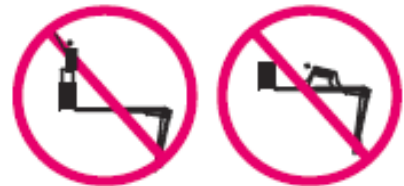

MANUAL FORCE

- **Never** push off or pull toward any object outside the platform.
- Maximum allowable manual force is 90 lb. (400 N).

WIND LOADING

- **Never** operate the aerial work platform in strong or winds that exceed 28 mph (12.5 m/s) or 45 km/h). **Never** increase the surface area of the platform or the load. Increasing the area exposed to the wind will decrease the aerial work platform stability.
- The Beaufort scale of wind force is accepted internationally and is used when communicating weather conditions. It consists of a number 0-10>, each representing a certain strength or velocity of wind at 10m (33ft) above ground level in the open. Refer to Table 1-2

TABLE 1-2. BEAUFORT SCALE

Description of wind		Specifications for use on land	m/h	Km/Hr	m/s
0	Calm	Calm; smoke rises vertically.	1	0-1	0-0.3
1	Light Air	Direction of wind shown by smoke.	1-3	1-5	0.3-1.5
2	Light Breeze	Wind felt on face; leaves rustle; ordinary vanes moved by wind.	4-7	6-11	1.6-3.3
3	Gentle Breeze	Leaves and small twigs in constant motion; wind exceeds light flag.	8-12	12-19	3.4-5.4
4	Moderate Breeze	Raises dust and loose paper; small branches are moved.	13-17	20-28	5.5-7.9
5	Fresh Breeze	Small trees in leaf begin to sway; crested wavelets form on inland waterways.	18-24	29-38	8.0-10.7
6	Strong Breeze	Large branches in motion; whistling heard in telephone wires; umbrellas used with difficulty.	25-30	39-49	10.8-13.8
7	Near Gale	Whole trees in motion; inconvenience felt when walking against wind.	31-38	50-61	13.9-17.1
8	Gale	Breaks twigs off trees; generally impedes progress.	39-46	62-74	17.2-20.7
9	Strong Gale	Slight structural damage occurs (chimney pots and slates removed).	47-54	75-88	20.8-24.4
10>	Storm, Violent Storm, Hurricane	Trees uprooted, widespread damage to structures, widespread devastation	55>	89>	24.5>

EXPLOSION HAZARD

- **NEVER** operate aerial work platform if you smell or detect Liquid Petroleum Gas (LPG), gasoline, diesel fuel or other explosive substances.
- **ALWAYS** charge Batteries in an open, well-ventilated area away from sparks, flames and lighted tobacco.

If this aerial work platform is equipped with a generator:

- **NEVER** refuel with the engine running.
- **NEVER** operate engine unless in a well-ventilated area to avoid carbon monoxide poisoning.

MAINTENANCE

Ensure the following general safety precautions are followed while performing maintenance on the aerial work platform:

General Maintenance

ALWAYS perform maintenance procedures according to manufacturer's guidelines. **NEVER** disregard or bypass proper maintenance procedures.

ALWAYS inspect hydraulic system to ensure that all lines, connectors and fittings are properly fastened and are in good condition.

ALWAYS turn the key switch to the "OFF" position and remove key before performing maintenance.

Whenever possible, **ALWAYS** perform maintenance with the boom and platform in its fully lowered, "stowed" position.

ALWAYS secure the boom before performing maintenance on hydraulic cylinders.

ALWAYS disconnect power to the hydraulic pump drive motor before making electrical checks to the hydraulic valves.

ALWAYS keep all mechanical parts properly adjusted and lubricated according to maintenance schedule and manufacturer / factory specifications. Refer to the "Equipment Maintenance" section of this manual.

ALWAYS perform a function check of operating controls before each use and after any repairs have been made.

ALWAYS locate and protect against possible pinch points before performing any maintenance or repairs.

ALWAYS use only manufacturer-approved parts to repair or maintain aerial work platform. If any portion of this aerial work platform is rebuilt or repaired, retesting is required in accordance with manufacturer / factory instructions.

ALWAYS maintain a safe distance while testing the hydraulic components. **ALWAYS** relieve hydraulic pressure before loosening or removing hydraulic components. **NEVER** test or operate the hydraulic components while personnel are near the aerial work platform.

NEVER allow water or foreign particles into the DC electric motor housing. Inclusion of water or foreign particles may cause serious damage to the motor. If the motor becomes wet, refer to the "Motor Drying Instructions" located in the Equipment Maintenance section of this manual, or contact the Haulotte Customer Service Department: at 1-800-537-0540 for proper drying instructions.

NEVER add unauthorized fluids to the hydraulic system or battery. **NEVER** mix hydraulic oils. Consult manufacturer specifications. Refer to the "Equipment Maintenance" section of this manual for hydraulic system maintenance procedures. Refer to the next page for Battery maintenance.

NEVER exceed the manufacturer's recommended relief valve settings.

NEVER touch or allow metal tools to contact any components that are sensitive to static discharge. **ALWAYS** use static discharge prevention mats and grounding devices when handling electronic components.

NEVER adjust, repair, replace or bypass any hydraulic or electrical control or safety device. These include, but are not limited to; hydraulic load control and flow control valves, solenoid valves and limit switches. **ALWAYS** consult an authorized Haulotte Group technician by contacting the Customer Service Department: at 1-800-537-0540 if repairs are necessary.

NEVER modify, alter or change the aerial work platform without first consulting an authorized Haulotte Group technician, and **NEVER** in any way that would affect its original design or operation.

MAINTENANCE (CONTINUED)

Battery Maintenance

Ensure the following general safety precautions are followed when performing battery maintenance on the aerial work platform:

ALWAYS check the battery fluid level daily.

ALWAYS wear safety glasses when working with or near batteries.

ALWAYS avoid contact with battery acid. Battery acid causes serious burns and should be kept away from skin or eyes. If contact occurs, flush with water and consult a physician immediately.

ALWAYS disconnect ground cable first when removing battery.

ALWAYS connect ground cable last when installing battery.

ALWAYS charge batteries in open, well-ventilated areas.

ALWAYS replace batteries using only parts recommended by manufacturer / factory. **ALWAYS** use only batteries with sealed caps over cells.

NEVER smoke while servicing batteries.

NEVER charge batteries near flammable materials.

NEVER allow batteries to overcharge and boil.

NEVER short across battery posts to check for current. **NEVER** break a live circuit at the battery.

NEVER disconnect battery from charger while charger is connected to a live power source.

NEVER jump-start other vehicles using the aerial work platform batteries.

2 SPECIFICATIONS

The following information is based on ideal working conditions. Machine performance may vary based on work environment and on machine options.

Only one telescoping boom motion is permitted at a time and only as long as the telescoping boom is within the safe operating zone. When a selected telescoping boom motion exceeds a safe operating limit, the telescoping boom motion ceases and another telescoping boom motion must be selected within the safe operating zone. Refer to Figure 2-1.

RANGE OF MOTION

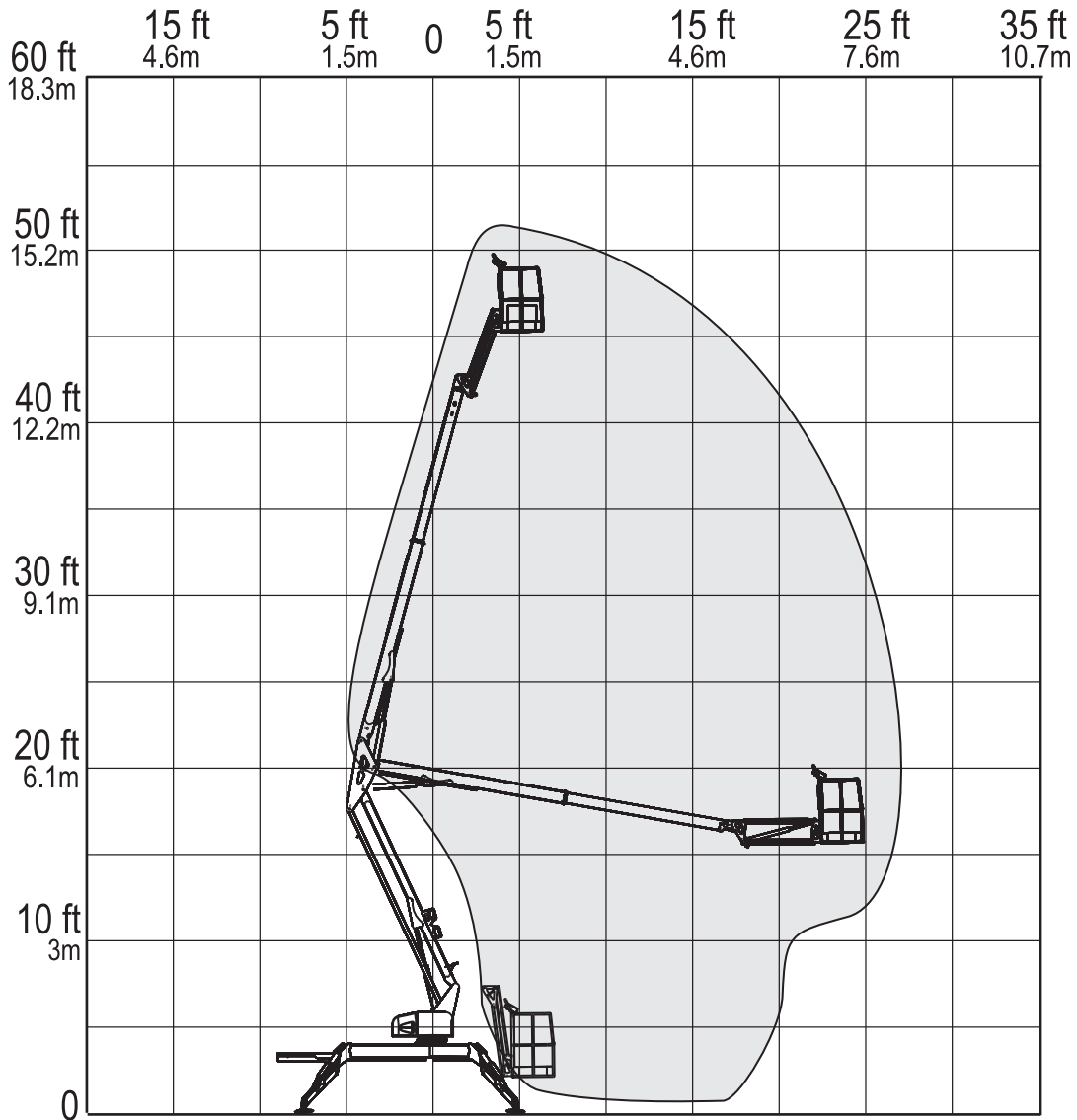

Figure 2-1. Range of Motion

SPECIFICATIONS	
Maximum Working Height	51 ft (15.7 m)
Maximum Platform Height	45 ft (13.7 m)
Up and Over Height	20 ft 9 in (6.3 m)
Maximum Horizontal Outreach	
From Centerline	27 ft (8.2 m)
From Outrigger Footpad Edge	21 ft (6.4 m)
Rated Platform Capacity	
Without Platform Rotation	500 lb (227 kg)
With Platform Rotation	440 lb (200 kg)
Maximum Occupants	2
Total Weight	
Without Options	4,200 lb (1,905 kg)
Drive and set option adds 250 lbs (113 kg), Engine option adds 190 lbs (86 kg)	
All other options add 150 lbs (68 kg) to weight.	
Turntable Rotation	700° Non-Continuous
Leveling Capability	12.5°
Platform Dimensions	
Height	3 ft 7 in (1.1 m)
Length	2 ft 6 in (0.8 m)
Width	4 ft 0 in (1.2 m)
Platform Rotation / Type (Optional)	120° / Manual
Machines Stowed Dimensions	
Height	6 ft 5 in (2.0 m)
Length	19 ft 6 in (5.9 m)
Width	5 ft 5 in (1.7 m)
Jib Dimensions	
Length	4 ft 3 in (1.3 m)
Vertical Motion	150° (+70° / -80°)
Outrigger Footprint (To Center of Pad)	
Length	12 ft 4 in (3.8 m)
Width	11 ft 4 in (3.5 m)
Footpad Diameter	12.5 in (0.3 m)
Parking Brake	Mechanical
Towing Brake	Hydraulic Surge Mechanical Electrical
Rated Towing Speed	65 mph (105 km/h)
Tire Size	ST 225/75 R15D
Control System	24V DC
Battery Chargers	4 x 6V 245 amp-hr 110 Volt 60 Hz 220 Volt 50 Hz
Hydraulic Pressure	3,000 psi (207 bar) (20,684 kPa)

SPECIFICATIONS (CONTINUED)	
Reservoir Capacity	4.3 Gallons (16.3 L)
Hydraulic System Capacity	6.3 Gallons (23.9 L)
Hydraulic Oil (Standard)	HVI AW32
Maximum Decibel Level	
DC Mode – Ground (Lower)	60 dBA
DC Mode – Platform (Upper)	55 dBA
Engine Mode – Ground (Lower)	70 dBA
Engine Mode – Platform (Upper)	65 dBA
Function Speeds	
Boom - Primary	
Primary, Up - Fast	24-28 sec
Primary, Up - Slow	56-60 sec
Primary, Down – Fast	22-26 sec
Primary, Down - Slow	92-96 sec
Boom - Secondary	
Secondary Up - Fast	20-24 sec
Secondary Up - Slow	40-44 sec
Secondary Down - Fast	34-38 sec
Secondary Down - Slow	95-100 sec
Boom - Jib	
Jib, Up – Fast	8-12 sec
Jib, Up - Slow	14-18 sec
Jib, Down - Fast	24-28 sec
Jib, Down - Slow	42-46 sec
Extension Boom	
Boom Extend - Fast	24-28 sec
Boom Extend - Slow	52-56 sec
Boom Retract - Fast	28-32 sec
Boom Retract - Slow	60-64 sec
Turntable - 700° Non-Continuous Rotation	
Turntable Rotation - Fast	205-209 sec
Turntable Rotation - Slow	335-339 sec
Platform	
Platform Compensation - Up - Fast	8-12 sec
Platform Compensation - Up - Slow	8-12 sec
Platform Compensation - Down - Fast	6-10 sec
Platform Compensation - Down - Slow	6-10 sec
Outrigger (Auto Level)	
Outrigger Extend	16-20 sec
Outrigger Retract	30-34 sec
Localized Pressure per Outrigger	25 psi (1.8 kg/cm ²) (176.5 kPa)
Operating Temperature Range	-20° to 110° Fahrenheit (-29° to 43° Celsius)

WARRANTY - NEW PRODUCT; HAULOTTE NORTH AMERICA

Haulotte US Inc (Haulotte) warrants its new products made by it to be free from defects in material or workmanship for twelve (12) months under normal operational conditions from the warranty start date (delivery date).

In addition, Haulotte further warrants the structural elements of each new product made by it, as defined in its then current warranty policies and procedures, to be free from defects in material or workmanship for five (5) years from the warranty start date (delivery date).

Haulotte agrees to repair or replace at its own expense; at its facility in Frederick MD, or at an authorized repair facility designated by Haulotte, any part or parts of the product found to be defective in material or workmanship, provided Haulotte is notified of such defect or defects within the applicable warranty period and given a reasonable time to correct the defect. In no case shall any warranty extend to defects in materials, components, or services furnished by third parties. Defects caused by chemical action or the presence of abrasive materials and defects arising following the operation beyond rated capacity or the improper use or application of any products shall not be considered defects within the scope of this warranty. If any repairs or alterations are made or any parts are replaced during the applicable warranty periods by anyone other than Haulotte or an entity authorized by Haulotte for use in its products, customer shall pay for such repairs or parts without recourse against Haulotte, and Haulotte should be relieved of responsibility for fulfillment of this warranty with respect to such repairs, alterations, or replacement so made. Haulotte obligations under this warranty shall at all times be subject to its current warranty policies and procedures. The above mentioned warranty shall not apply to replacement or service parts made and sold by Haulotte. Periodic maintenance, periodic maintenance items (including paint and decals), and minor adjustments are excluded from this warranty. Certain components, including, but not limited to, engines, tires and batteries, which may be part of the product are not manufactured or warranted by Haulotte. Any applicable warranty for such component is provided through the original manufacturer of the component or its distributor organization. Haulotte warranty does not apply to defects caused by negligence, misuse, accidental damage, inadequate or improper use or maintenance, acts of nature and normal wear and tear of the products.

Under no circumstances shall Haulotte be liable for any consequential or special damages which any person or entity may incur or claim to incur as a result of any defect in the product or in any correction or alteration thereof made or furnished by Haulotte or others. Consequential or special damage includes, but not limited to cost of transportation, lost sales, lost orders, lost profits, lost income, increased over head, labor and material costs, and cost of manufacturing variances and operational inefficiencies. Haulotte maximum liability under this warranty shall be the purchase price paid to Haulotte with respect to the product to which such warranty is claimed. This warranty constitutes Haulotte entire and exclusive warranty as to the product and is the sole and exclusive remedy for the product defects in material and workmanship. Haulotte does not assume (and has not authorized any other person to assume on its behalf) any other warranty or liability in connection with any product covered by this warranty.

Haulotte expressly disclaims any and all other warranties of any kind whatsoever as to the product furnished hereunder, including but not limited to any express warranties, except for the exclusive warranty provided herein, or implied warranties as to merchantability, or fitness for any particular purpose.

This warranty shall be void, if, upon the occurrence of any incident involving any product made by Haulotte and resulting in any personal injury or property damage, customer shall fail to notify Haulotte within 48 hours of such occurrence or permit Haulotte and its representatives to have immediate access to such product and all records of or within the control of the customer relating to the product and occurrence. For the procedure to apply for warranty please refer to the warranty procedure (document # QC-00001).

North America Warranty 2010/4.

QC-00002

WARRANTY CLAIMS PROCEDURE

In order to qualify for warranty coverage, the following conditions must be met:

- 1) Return of completed "Warranty Registration" form to Haulotte Group|BilJax within 15 days of receipt of product;
- 2) Notification to Haulotte Group|BilJax Service within 48 hours of any claimed defect, or damage resulting from the claimed defect;
- 3) Warranty is limited to parts that are determined to be defective by an authorized service dealership in conjunction with Haulotte Group|BilJax Service. This does not include parts worn out due to normal wear and tear.

Haulotte Group|BilJax authorized dealers or distributors are responsible for filing claims under warranty. Listed below is the warranty claims procedure.

- 1) Contact Haulotte Group|BilJax Customer Service Department: at 1-800-537-0540 or visit Haulotte Group online at www.haulotte-usa.com to report the claim and verify warranty coverage. Machine serial number and machine hours must be provided when call is placed. A call ID number will be created when the call is placed. The service representative will issue the call ID number to you at the end of the call.
- 2) Identify the components to be claimed under warranty along with description of failure. An RMA number will be issued from Haulotte Group|BilJax to return warranty parts at the time the parts order is placed.
- 3) Replacement parts will then be sent by Haulotte Group|BilJax to the dealer or distributor. All parts are invoiced at dealer|distributor list price. Credits will be issued when defective parts are returned to Haulotte Group|BilJax under the proper RMA number and found to be defective under warranty.
- 4) After completing repairs, submit warranty application form and return the defective parts to Haulotte Group|BilJax. Warranty application form and parts must be received within 30 days of claim in order to be eligible for credit. Returned parts are to be sent prepaid and will be credited when part is received and verified. Warranty labor rate will be paid at current rate set by Haulotte Group|BilJax. The amount of labor hours reimbursed will be determined by Haulotte Group|BilJax and will be limited to 4 hours unless approved by Haulotte Group|BilJax Service.
- 5) The warranty application must include; the issued RMA number, the invoice number for the associated parts, the machine serial number, the machine hours on the date of failure, the issued call ID number, failure and repair description, and requested customer information.

Failure to follow the warranty claims procedure may result in delay in processing claim or denial of the claim. Haulotte Group|BilJax reserves the right to limit or adjust warranty claims with regard to parts, labor, and travel time. Replacement components purchased from suppliers other than Haulotte Group|BilJax are not covered under the terms of this warranty.

QC-00001

DAMAGED EQUIPMENT POLICY

Safety Statement

At Haulotte Group we are dedicated to the safety of all users of our products. All Haulotte Group aerial work platforms are designed, manufactured and tested to comply with current applicable ANSI, CSA, AS and / or CE Standards and regulations.

Damage Policy

There may be occasions when a Haulotte Group aerial work platform is involved in an incident that results in structural damage to the aerial work platform. Such damage can seriously compromise the ability of the aerial work platform to perform in a safe manner. Therefore, whenever a Haulotte Group aerial work platform has sustained visual structural damage, or when there is suspected internal structural damage, Haulotte Group may require that the aerial work platform be returned to our facility for a complete inspection and recertification. For any questions concerning whether your aerial work platform may have sustained structural damage or the Damaged Equipment Policy, please direct any questions to the Haulotte Group Customer Service Department: at 1-800-537-0540 or visit Haulotte Group online at www.haulotte-usa.com.

Damage Repair Notice

There may be occasions when a Haulotte Group aerial work platform is involved in an accident resulting in damage to non-structural components. When such damage occurs and repairs are made by the owner or area distributor, please notify Haulotte Group of these non-maintenance repairs and request a repair form to be filled out and returned to Haulotte Group.

3 OPERATION

The 4527A / HTA 16 P Articulating Boom Lift is a Summit Series™ trailer-mounted aerial work platform, designed and manufactured to position personnel with their tools and equipment at overhead work locations. The platform load capacity is rated at 500 pounds (227 kilograms). During all aerial work platform operations, four extended outriggers support the unit.

The aerial work platform is battery powered and operated with electronic pushbutton controls, a hydraulic power unit, a hydraulic gear motor and hydraulic cylinders. The hydraulic power unit includes a reservoir, pump and control valves. Hydraulic cylinders elevate and extend the telescoping boom and maintain the platform at level during operation. The hydraulic motor and mating worm gear allows the boom to rotate 700° Non-Continuous around a vertical axis.

The hydraulic power unit uses a 24-Volt, one horsepower DC motor to drive the hydraulic pump. The DC motor is powered by four 6-Volt DC, 245 amp-hour deep charge batteries connected in series. An automatic onboard battery charger is provided for recharging the batteries at the end of each work period.

The ground (lower) control panel controls the power, outriggers, boom lift elevation, and rotation functions.

The platform (upper) control panel only controls boom lift elevation, and rotation.

Note: The elevation and rotation controls are operational only when the outriggers are correctly extended and the extension boom is within a programmed safe operating zone.

The ground (lower) control panel includes a lighted text window that displays the current operating status or an existing error condition.

Safety devices prevent the boom from retracting suddenly in the event of a hydraulic hose or system failure. It is strongly recommended that no one adjust or tamper with these safety devices. If service is required, contact the Customer Service Department: at 1-800-537-0540 or visit Haulotte Group online at www.haulotte-usa.com.

In the event of power loss, control system failure or other malfunction, boom lowering functions may be accomplished manually.

To manually operate boom retraction, and turntable rotation functions, use the hand pump, and selected valves on the hydraulic pump unit that can be accessed inside the pump compartment.

Manual lowering of the boom and platform may also be performed by actuating the valve plunger found on the base of each boom lift cylinder. Pushing in and holding the valve "button" on the appropriate cylinder retracts that cylinder, thereby retracting that part of the boom. The boom may need to be rotated to a clear area before lowering.

GROUND (LOWER) CONTROL PANEL

The ground (lower) control panel is used to operate outriggers and control all boom functions. To access the ground (lower) control panel, open the control panel access cover found on the turntable. The ground (lower) control panel includes the following controls and indicators. Refer to Figure 3-1.

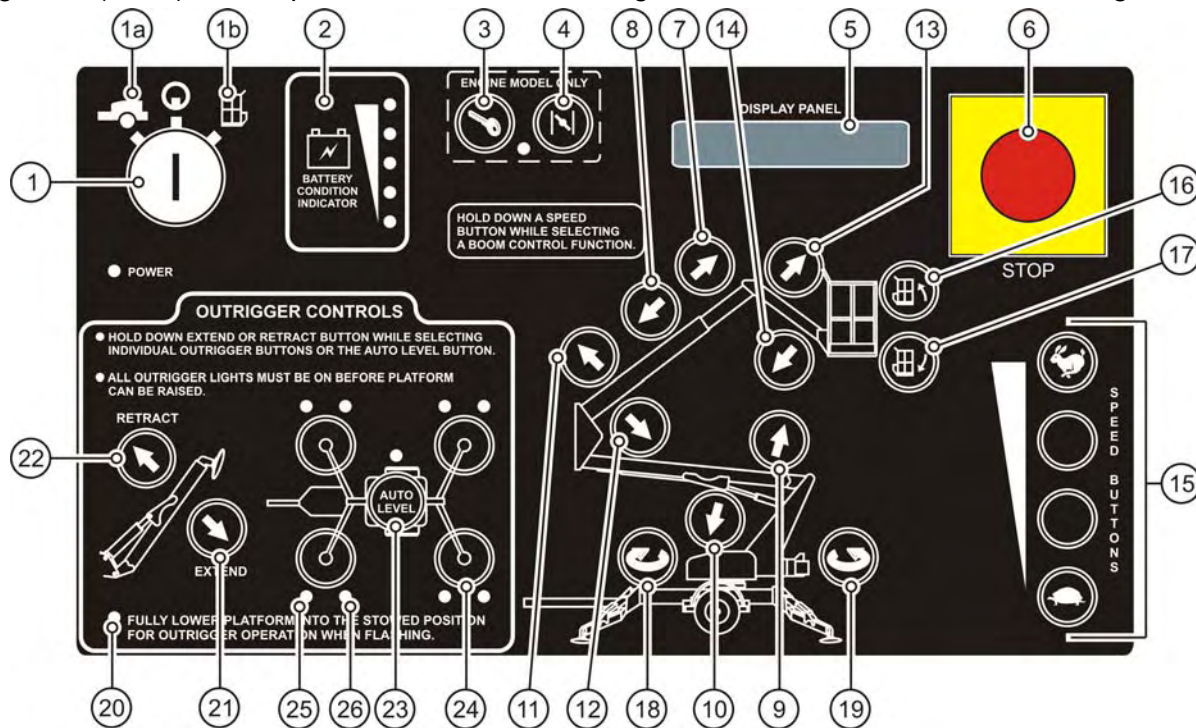

Figure 3-1. Ground (Lower) Control Panel

1. Key Switch

Turning the **KEY SWITCH (1)** counter clockwise to the **GROUND (1a)** icon selects operation from the ground (lower) control panel. Turning the **KEY SWITCH (1)**, clockwise to the **PLATFORM (1b)** icon selects operation from the platform (upper) control panel. Turning the **KEY SWITCH (1)** to the vertical position (power “OFF”) interrupts all electric and hydraulic power operations except emergency lowering. Removal of the **KEY** protects against any unauthorized person attempting to operate the aerial work platform. The **KEY** may be removed with the **KEY SWITCH (1)** in any selected position.

2. Battery Condition Indicator

Indicator LEDs light up to indicate the level of charge in the batteries.

- A lighted green LED indicates an adequate charge level.
- A lighted yellow LED indicates the need for charging soon.
- A lighted red LED warns that the battery charge level is low; all functional operations become non-functional until the batteries are recharged.

3-4. Engine Choke and Start / Glow Plug (Models with Engines Only)

Start a cold engine by pressing (pushing) in and holding the **CHOKE (4)** button then press (push) the **ENGINE START (3)** button. To start / restart a warm engine, press (push) the **ENGINE START (3)** button only. **GLOW PLUG OPERATION** – Press (push) and hold for 30-60 seconds then press (push) the **ENGINE START (3)** button.

5. Display Panel

The **DISPLAY PANEL** is a lighted text window that displays the current operating status or an existing error condition when the **KEY SWITCH (1)** is positioned at either **(1a)** or **(1b)**.

6. Emergency Stop Button

When pushed in, the **EMERGENCY STOP (6)** button disconnects electrical power to the ground (lower) and platform (upper) control panels. The **EMERGENCY STOP** button should only be pressed (pushed) in to immediately stop all aerial work platform motion. To resume control, “pull out” the **EMERGENCY STOP (6)** button.

GROUND (LOWER) CONTROL PANEL (CONTINUED)

7-8. Boom Extend / Retract Buttons

Pressing (pushing) in and holding a desired **SPEED (15)** button, and the **BOOM EXTEND (7)** button at the same time extends the secondary boom. Pressing (pushing) in and holding a desired **SPEED (15)** button, and the **BOOM RETRACT (8)** button at the same time retracts the secondary boom. Telescopic boom motion continues until the buttons are released, or until the boom reaches a hard stop, or a safe travel limit.

9-14. Boom Raise / Down (Lower) Buttons and Jib Raise / Down (Lower) Buttons

- Pressing (pushing) and holding a desired **SPEED (15)** button, and the **PRIMARY BOOM RAISE (9)** button at the same time will raise the primary boom. Pressing (pushing) and holding a desired **SPEED (15)** button, and the **PRIMARY BOOM DOWN (10)** button at the same time will retract the primary boom.
- Pressing (pushing) and holding a desired **SPEED (15)** button, and the **SECONDARY BOOM RAISE (11)** button at the same time will raise the secondary boom. Pressing (pushing) and holding a desired **SPEED (15)** button, and the **SECONDARY BOOM DOWN (12)** button at the same time will retract the secondary boom.
- Pressing (pushing) and holding a desired **SPEED (15)** button, and the **JIB BOOM RAISE (13)** button at the same time will raise the **JIB BOOM**, pressing (pushing) and holding a desired **SPEED (15)** button, and the **JIB BOOM DOWN (14)** button at the same time will retract the **JIB BOOM**.

The selected Boom motion continues until the buttons are released or until the selected boom reaches a hard stop or a safe travel limit.

15. Speed Buttons

The **SPEED (15)** buttons are located along the lower right side of the control panel, one of the speed buttons must be pressed (pushed) in and held while selecting the various boom functions. There are four speeds that range from fast (**RABBIT**), to slow (**TURTLE**), available to help control the positioning of the Boom and the Jib.

16-17. Platform Tilt Buttons

Press (push) and hold any **SPEED (15)** button, and the desired **PLATFORM TILT UP (16)** or **PLATFORM TILT DOWN (17)** button at the same time to level the work platform (this levels the platform only, NOT the aerial work platform).

18-19. Boom Rotation Buttons

Pressing (pushing) and holding a desired **SPEED (15)** button, and the **BOOM ROTATION (18)** button at the same time enables the boom to rotate in the **CLOCKWISE** direction. Pressing (pushing) and holding a desired **SPEED (15)** button, and the **BOOM ROTATION (19)** button at the same time enables the boom to rotate in the **COUNTER CLOCKWISE** direction. The boom will rotate through 700° of Non-Continuous rotation until the buttons are released or the stop is reached.

20. Outrigger Indicator LED

When this LED is "FLASHING" it indicates that the booms are not in the "stowed" position, and the outriggers are not functional. When this LED is "ON SOLID" it indicates that the booms are in the "stowed" position, and the outriggers are functional.

21-24. Outrigger Controls

For simultaneous automatic outrigger extension / retraction of all four (4) outriggers: Select the **EXTEND (21)** button or **RETRACT (22)** button and the **AUTO LEVEL (23)** button at the same time. To individually extend or retract the outriggers: Select the **EXTEND (21)** button or **RETRACT (22)** button, and one of the four **OUTRIGGER (24)** buttons at the same time. The outrigger indicator LED (**20**) lights up when the outriggers are properly deployed and the aerial work platform weight is on the outrigger foot pads. Each of the outer outrigger LEDs (**25**) indicates load is on the outrigger footpad. Each of the inner outrigger LEDs (**26**), when flashing, indicate that side is low, and needs to be further raised for leveling.

PLATFORM (UPPER) CONTROL PANEL

The platform (upper) control panel is used to control all boom functions. The platform (upper) control panel is activated by turning the **KEY SWITCH (1)** on the ground (lower) control panel, clockwise to the **PLATFORM (1b)** icon. Enter the work platform using a three (3) point contact (both hands and one foot).

The platform (upper) control panel includes the following controls and indicators. Refer to Figure 3-2.

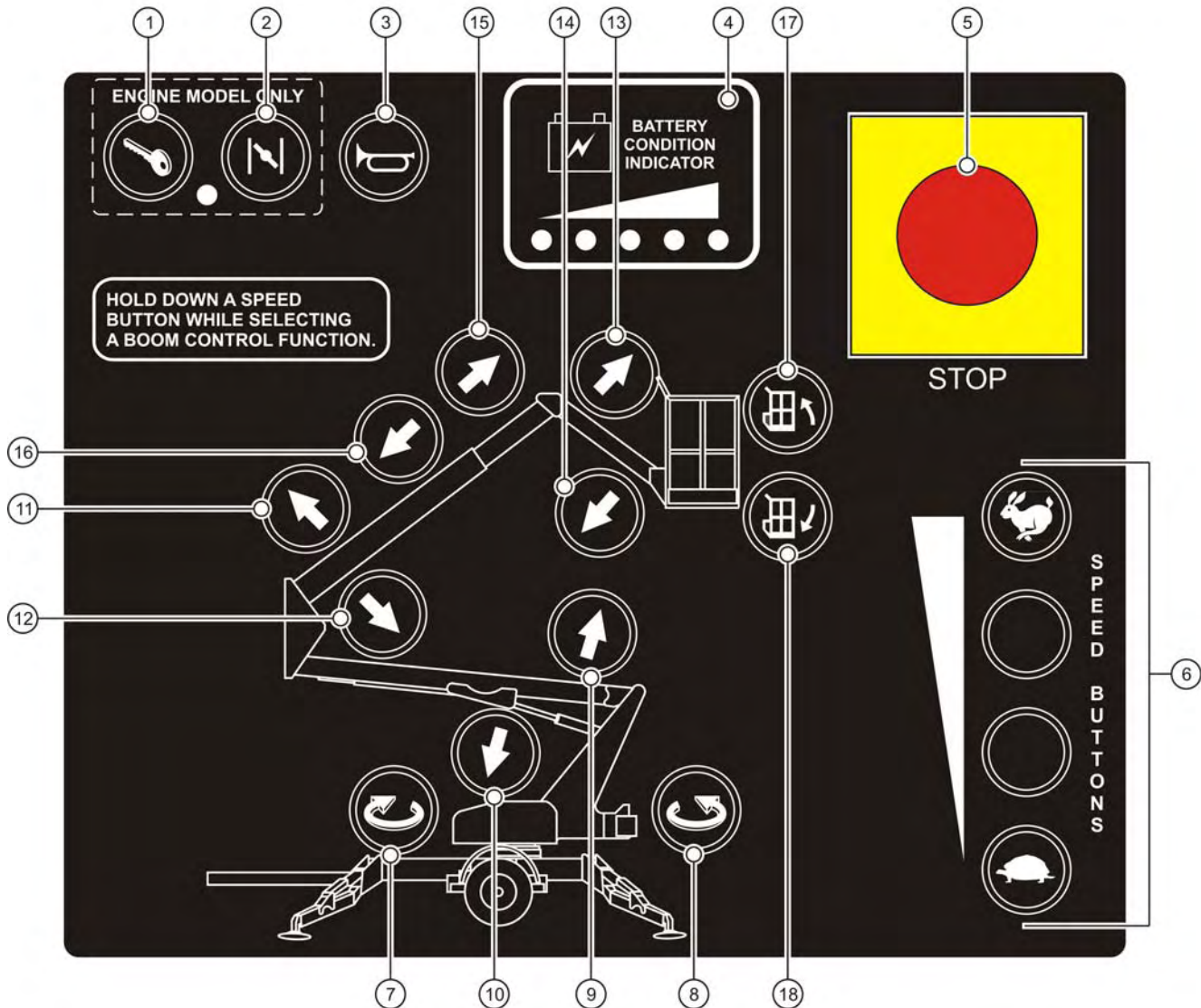

Figure 3-2. Platform (Upper) Control Panel

1-2. Engine Choke and Start / Glow Plug (Models with Engines Only)

Start a cold engine by pressing (pushing) and holding the **CHOKE (2)** button, and pressing (pushing) the **ENGINE START (1)** button to start the Engine. To start / restart a warm Engine, press (push) the **START (1)** button only.

GLOW PLUG OPERATION – Press (push) and hold the **GLOW PLUG (2)** button for 30-60 seconds then press (push) the **ENGINE START (1)** button.

3. Horn Button

Pressing (pushing) the **HORN (3)** button will sound the **HORN**. Use the **HORN (3)** button to warn personnel in the area of a falling object hazard, impending boom motions, or the need for assistance.

PLATFORM (UPPER) CONTROL PANEL (CONTINUED)

4. Battery Condition Indicator

Indicator LEDs light up to indicate the level of charge in the batteries.

- A lighted green LED indicates an adequate charge level.
- A lighted yellow LED indicates the need for charging soon.
- A lighted red LED warns that the battery charge level is low; all functional operations become non-functional until the batteries are recharged.

5. Emergency Stop Button

When pushed in, the **EMERGENCY STOP (5)** button disconnects electrical power to the ground (lower), and platform (upper) control panels. The **EMERGENCY STOP (5)** button should only be pressed (pushed) in to immediately stop all boom functions. To resume control, pull the **EMERGENCY STOP (5)** button out.

6. Speed Buttons

The **SPEED (6)** buttons are located along the lower right side of the control panel, one of the speed buttons must be pressed (pushed) in and held while selecting the various boom functions. There are four speeds that range from fast (**RABBIT**), to slow (**TURTLE**), available to help control the positioning of the Boom and the Jib.

7-8. Boom Rotation Buttons

Pressing (pushing) in and holding a desired **SPEED (6)** button and the **BOOM ROTATION (7)** button at the same time enables the boom to rotate in the **CLOCKWISE** direction. Pressing (pushing) and holding a desired **SPEED (6)** button and the **BOOM ROTATION (8)** button at the same time enables the boom to rotate in the **counter CLOCKWISE** direction. The boom will rotate through 700° of Non-Continuous rotation until the buttons are released or the stop is reached.

9-14. Boom Raise / Down Buttons and Jib Raise / Down Buttons

- Pressing (pushing) and holding a desired **SPEED (6)** button, and the **PRIMARY BOOM RAISE (9)** button at the same time will raise the primary boom, pressing and holding a desired **SPEED (6)** button, and the **PRIMARY BOOM DOWN (10)** button at the same time will lower the primary boom.
- Pressing (pushing) and holding a desired **SPEED (6)** button, and the **SECONDARY BOOM RAISE (11)** button at the same time will raise the secondary boom. Pressing (pushing) and holding a desired **SPEED (6)** button, and the **SECONDARY BOOM DOWN (12)** button at the same time will lower the secondary boom.
- Pressing (pushing) and holding a desired **SPEED (6)** button, and the **JIB BOOM RAISE (13)** button at the same time will raise the jib boom, pressing (pushing) and holding a desired **SPEED (6)** button, and the **JIB BOOM DOWN (14)** button at the same time will lower the **JIB BOOM**.

The selected Boom motion continues until the buttons are released or until the selected boom reaches a hard stop or a safe travel limit.

15-16. Boom Extend / Retract Buttons

Pressing (pushing) and holding a desired **SPEED (6)** button, and the **BOOM EXTEND (15)** button at the same time extends the secondary boom. Pressing (pushing) and holding a desired **SPEED (6)** button, and the **BOOM RETRACT (16)** button at the same time retracts the secondary boom. Telescopic boom motion continues until the buttons are released, or until the boom reaches a hard stop, or a safe travel limit.

17-18. Platform Tilt Buttons

Press (push) and hold any **SPEED (6)** button, and the desired **PLATFORM TILT UP (17)** or **PLATFORM TILT DOWN (18)** button at the same time to level the work platform (this levels the platform only, NOT the aerial work platform).

Outlet

An outlet has been provided as a power source for running electrical power tools, while in the work platform. The power plug is located on the trailer frame, in front of the accessory equipment stowage plate. A connecting power cord **must** be plugged into a suitable power source. The outlet is rated for a 15-ampere load. **DO NOT** overload the accessory power circuit.

NORMAL OPERATING PROCEDURE

Become familiar with the location and function of all controls. Learn to smoothly **START** and **STOP** all boom functions.

Perform the following procedures to operate the Haulotte Articulating Boom Lift.

- Read and obey all safety precautions and operating instructions, as well as all Federal, State, and Local codes and regulations.
- Conduct a Pre-Operation Inspection by performing all recommended Daily Service Checks. Refer to the “Equipment Maintenance” section of this manual.
- Position the aerial work platform at the work area. Make sure the aerial work platform is on a firm and level surface and there are no potential hazards such as overhead obstructions or electrically charged conductors. **DO NOT** operate the aerial work platform if such hazards exist.
- Apply the aerial work platform parking brake or chock the wheels.
- Lower the **TONGUE JACK / DOLLY WHEEL** and unhitch the aerial work platform from the tow vehicle.

WARNING

Failing to unhitch the aerial work platform before operation may lead to damage to equipment or tow vehicle and makes the aerial work platform unstable; this could result in death or serious injury.

- Release both boom travel latches, (1) on the Boom Rest, and (2) on the Primary Boom, by raising the latch handle and swinging the clasp down. Refer to Figure 3-3.



Figure 3-3. Boom Travel Latches

NORMAL OPERATING PROCEDURE (CONTINUED)

Become familiar with the location and function of all controls. Learn to smoothly **START** and **STOP** all boom functions.

- At the ground (lower) control panel, turn the **KEY SWITCH (1)** counter clockwise to the **GROUND CONTROLS (1a)** icon. If power does not come on, make sure that both of the **EMERGENCY STOP** buttons; **GROUND (6)**, and **PLATFORM (5)**, are pulled out and the main power disconnect plug is plugged in.
- The control microprocessor will perform self-diagnostics to test the operating system. After several seconds, the **DISPLAY PANEL** window will read:

HAULOTTE GROUP ACCESS SOLUTIONS

- Monitor the battery condition indicator during operation and charge the batteries as necessary.
- Extend the four outriggers individually, or for simultaneous extension use the **AUTO LEVEL (23)** button on the ground (lower) control panel. When the aerial work platform is leveled properly, a buzzer will sound, the two LEDs at each **OUTRIGGER (25 and 26)** button, and the LED at the **AUTO LEVEL (23)** button will be lit. Refer to Figure 3-4.

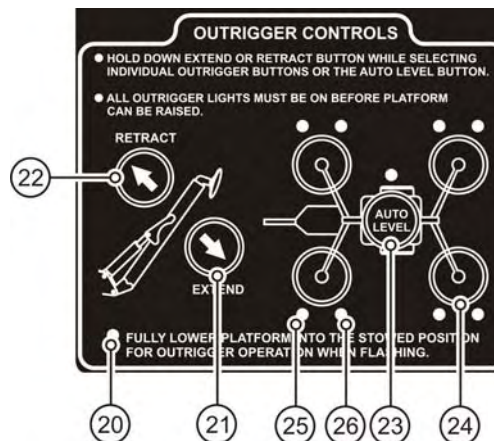

Figure 3-4. Outrigger Control Panel

- **Auto Level:** Press (push) and hold the **EXTEND (21)** and **AUTO LEVEL (23)** buttons at the same time.
- **Manual Level:** Extend the two outriggers closest to the trailer coupler first. Lower the front pair of outriggers by pressing (pushing) the **EXTEND (21)** button and the two front **OUTRIGGER** buttons at the same time. Lower the back pair of outriggers by pressing (pushing) the **EXTEND (21)** button and the two back **OUTRIGGER** buttons at the same time.
- Verify that the **AUTO LEVEL (23)** indicator LED is lit. If the **AUTO LEVEL (23)** indicator is not lit, the aerial work platform may not be level, and the weight of the machine may not be on the outrigger foot pad.

NOTE: If the boom is not level or if one or more outriggers are not supporting the machines load the safety interlock system prevents all boom operations.

NOTE: The Range of Motion Diagram at the ground (lower) and platform (upper) control stations displays the range of platform motion (safe operating zone) facing away from the trailer tongue. Verify that the operating zone is clear of obstructions through 700° of Non-Continuous rotation.

NORMAL OPERATING PROCEDURE (CONTINUED)

- Use the ground (lower) control panel to operate the boom lift functions. Raise, lower, extend and rotate the booms by pressing (pushing) and holding the desired **SPEED** and function buttons at the same time.
- Fully lower the boom onto the boom rest to enter the platform using a three (3) point contact (both hands and one foot).
- Raise the safety bar and enter the work platform by using a three (3) point contact (both hands and one foot). Put on a safety harness and attach the lanyard to the **ANCHORAGE** (attachment point) on the side of the platform support beam.
- Should the platform become tilted out of the normal vertical axis, press (push) and hold the desired **SPEED (6)** button and one of the **PLATFORM TILT (16)** or **(17)** buttons at the same time to level the platform back into the normal vertical axis.
- Use the platform (upper) control panel to operate the boom lift functions. Raise, lower, extend and rotate the boom by pressing (pushing) and holding the desired **SPEED (6)** and desired function button at the same time. Become familiar with the location and function of all controls. Learn to smoothly **START** and **STOP** all boom functions.
- When all aerial work platform operations are complete, fully retract all boom extensions. Center the boom over the boom rest and fully lower the boom until seated in the “stowed” position for transport.

NOTE: Always fully retract, rotate and lower the boom to the “stowed” position before exiting the platform.

- Turn the key switch to the **GROUND CONTROLS (1a)** position.
- Unfasten the safety harness and exit the platform by using a three (3) point contact (both hands and one foot).
- Engage both travel latches.

NOTE: Refer back to earlier in this section to Figure 3-3 for a visual of these latches.

- Inspect the area beneath the aerial work platform and trailer for obstructions before retracting outriggers. Press (push) and hold the outrigger **RETRACT (22)** button and the **AUTO LEVEL (23)** button until all outriggers are fully retracted to their “stowed” (upright) positions.

NOTE: Safety switches prevent outrigger retraction until the boom is completely lowered and in the “stowed” position.

- At the ground (lower) control panel turn the **KEY SWITCH (1)** to the vertical (power “OFF”) position, and remove the key.

MANUAL BOOM OPERATION

Manual retraction, rotation and lowering functions allow the booms to be moved and lowered during hydraulic power interruption or failure.

The following procedures for manual retraction, rotation and lowering require a person on the ground to operate the manual controls and hand pump.

The hydraulic hand pump is located in the pump compartment. In case of a power failure, the hand pump and selected hydraulic valve can be used to manually retract the booms or rotate the boom turntable.

Manual Retraction

Begin manual retraction or rotation, by turning the proportional valve counterclockwise until it stops; insert the pump handle into the pump handle fitting. Pushing and holding the **RETRACT** button while simultaneously actuating the **HAND PUMP** will retract the secondary boom.

Refer to Figure 3-5.

Manual Rotation

To rotate the TURNTABLE clockwise:

Push and hold the **ROTATION** button **IN** and simultaneously actuate the **HAND PUMP**.

To rotate the TURNTABLE counterclockwise:

Pull the **ROTATION** button **OUT** and simultaneously actuate the **HAND PUMP**.

NOTE: Turn the **PROPORTIONAL VALVE** clockwise to return it to its original position before lowering the booms or resuming normal operation.

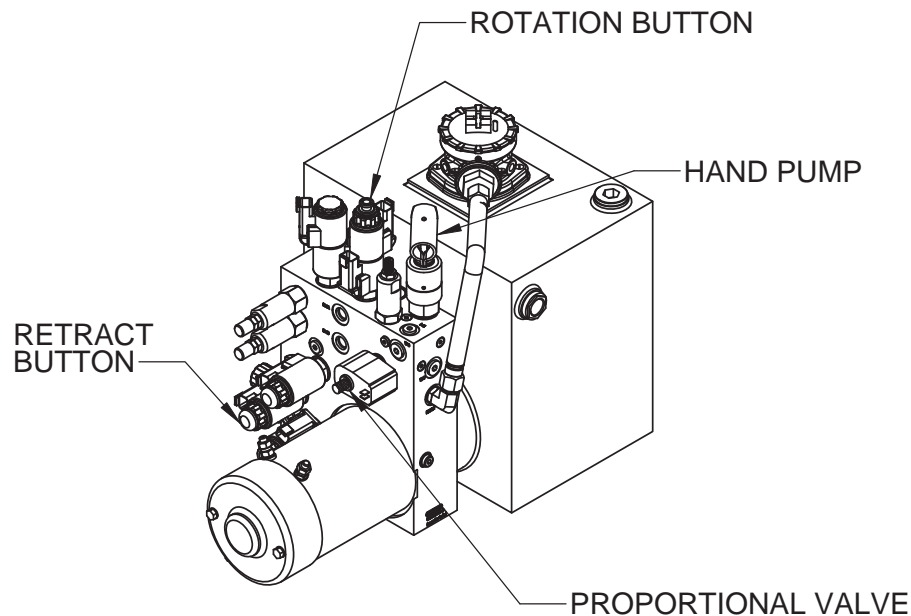

Figure 3-5. Hand Pump Controls for Manual Operation

MANUAL BOOM OPERATION (CONTINUED)

Manual Boom Lowering Procedure

Each lift cylinder is equipped with a manual **LOWERING VALVE**, found at the base of each lift cylinder. Use the **VALVE** to lower the platform in case of a complete electrical power failure, a load shift, or other emergency. The booms may be lowered in any order, but the logical order would be:

- The **PRIMARY** boom first.
- The **SECONDARY** boom next.
- The **JIB** boom last.

To lower the boom, push in on the **LOWERING VALVE** "button" of the cylinder that controls the boom that is to be lowered. Follow this procedure until the boom is completely lowered.

Refer to Figures 3-6 and 3-7.

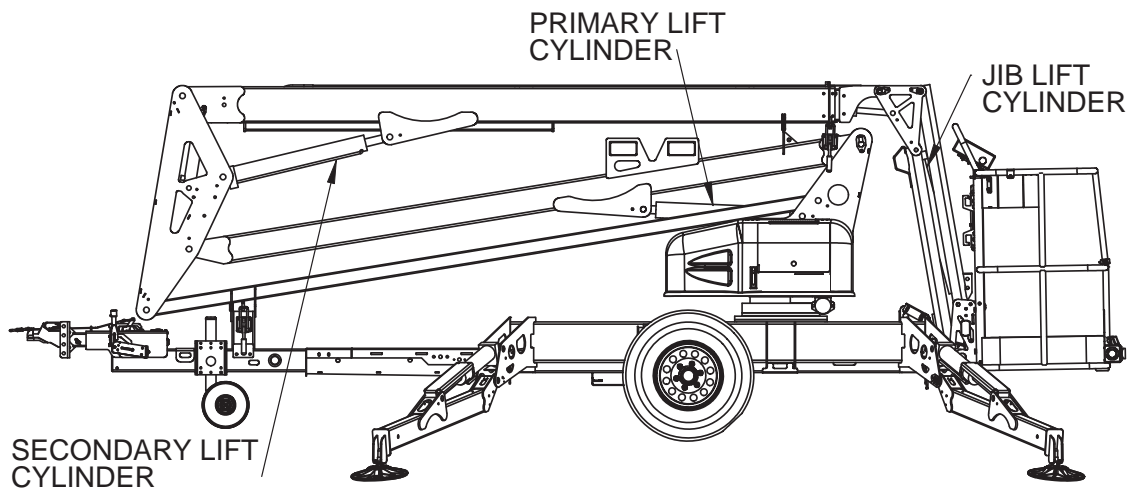

Figure 3-6. Location of Lift Cylinders

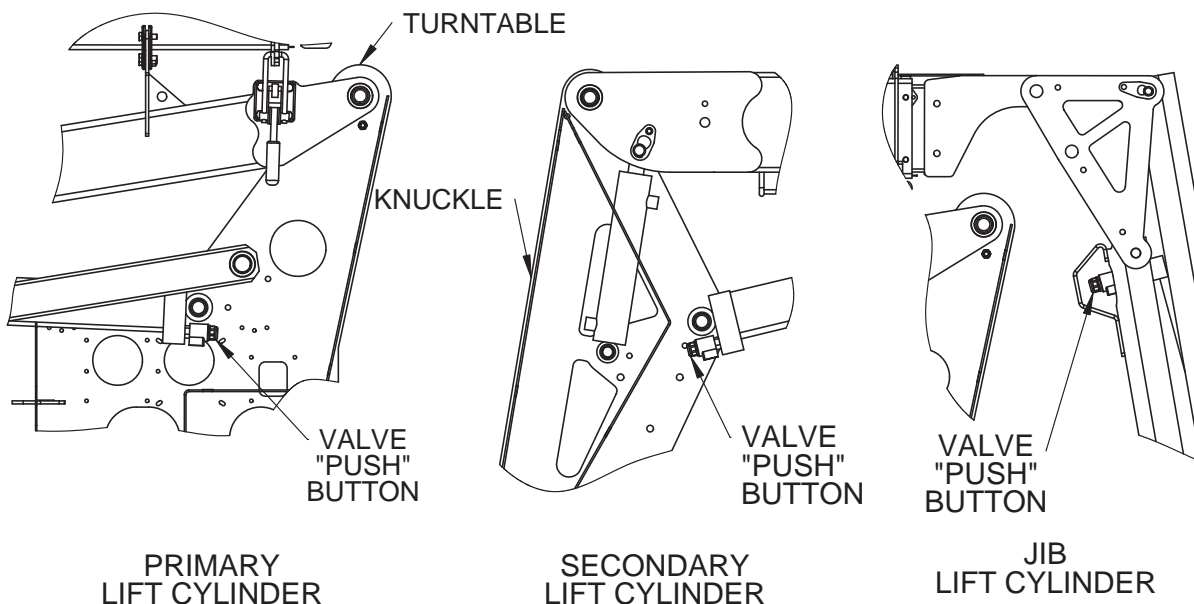

Figure 3-7. Location of Manual Lowering Valves

TOWING THE AERIAL WORK PLATFORM

The aerial work platform trailer includes a single axle, two-inch ball hitch, hydraulic surge brakes, mechanical parking brake, safety chains, brake lights and side marker lights. Proper aerial work platform transport requires the proper inspection and attachment of these components before towing.

Verify the following before towing the aerial work platform. Make adjustments as necessary.

- The **TONGUE JACK / DOLLY WHEEL** and outriggers are in their travel positions. The **TONGUE JACK / DOLLY WHEEL** is rotated up so that the **TONGUE JACK / DOLLY WHEEL** assembly is parallel with the tongue tube; the outrigger cylinders are fully retracted.
- Boom travel latches are engaged, securing the telescoping booms in their fully “stowed” positions.
- All on-board equipment is secured.
- The key switch is in the “OFF” position. Remove the key.
- The parking brake is disengaged. When the parking brake is engaged it is parallel with the tongue tube, when disengaged it is perpendicular to the tongue.
- The trailer tires are adequately and evenly inflated. See the side wall of the tire for proper inflation.

Periodically check the Wheel Nut torque according to manufacturer’s recommendations. Refer to the Monthly Service check section, in the Equipment Maintenance section of this manual.

NEVER tow an aerial work platform with worn or damaged wheel components.

NOTICE

Prior to towing, while the trailer wheels are elevated for aerial work platform operation, inspect for loose wheels and for lug nuts wear. If a loose wheel mounting is suspected, remove and inspect lug nuts for damage.



CAUTION

Obtain, read and obey all recommendations set forth by the tow vehicle manufacturer before attempting to transport aerial work platform. Verify that aerial work platform weight does not exceed the vehicle’s towing capacity. Exceeding the tow vehicle’s rated capacity may result in damage to tow vehicle or aerial work platform.

TOWING THE AERIAL WORK PLATFORM (CONTINUED)

Procedure to hitch and tow the aerial work platform.

Back the tow vehicle to the trailer. Verify that the ball and trailer hitch are aligned and that the trailer hitch has proper clearance above the ball.

Refer to Figure 3-8.

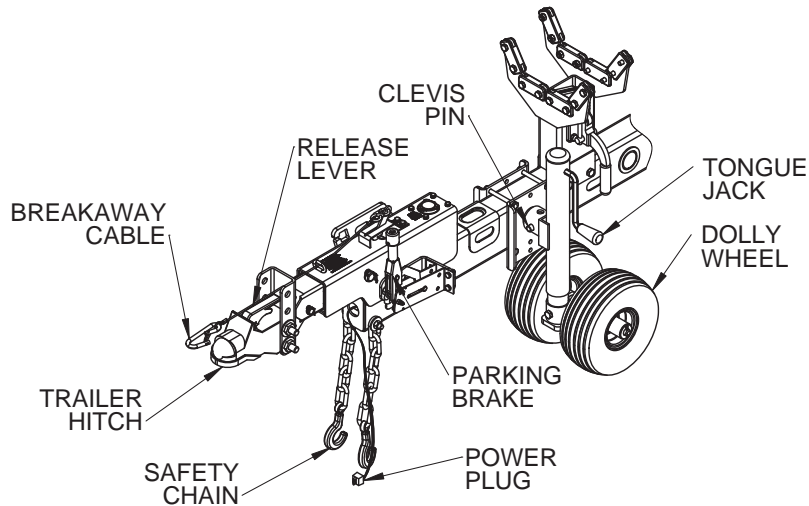

Figure 3-8. Trailer Hitching

- Lift the **RELEASE LEVER** on the **TRAILER HITCH**, and lower the hitch onto the ball using the **TONGUE JACK / DOLLY WHEEL**. Push down on the **RELEASE LEVER** to secure the ball.
- Use the **TONGUE JACK / DOLLY WHEEL** to verify that the coupling is secure.

NOTE: If using the jack raises the bumper of the tow vehicle 2-3 inches, the ball hitch coupling is secure.

- Release the **PARKING BRAKE** by rotating the handle down until it is parallel with the tongue tube.
- On the **TONGUE JACK / DOLLY WHEEL**, pull the **CLEVIS PIN**, and swivel the **TONGUE JACK / DOLLY WHEEL** 90° to the travel position. Re-engage the **CLEVIS PIN**.
- Attach the safety chains to the tow vehicle. Verify that the chains cross under the trailer tongue.



CAUTION

Failure to attach safety chains properly before towing will allow trailer tongue to drop in case of ball hitch failure, resulting in damage to tow vehicle and aerial work platform.

- For models with the breakaway cable; connect it to the tow vehicle. Leave adequate slack to prevent brakes from dragging.
- Connect the trailer lights to the tow vehicle power plug.

LIFTING THE AERIAL WORK PLATFORM

Refer to Figure 3-9.

Completely retract and lower all booms.

- Secure both boom travel latches **(A)**.
- Remove all loose materials from the machine.
- Retract all outrigger cylinders to the fully “stowed” (upright) position.
- When using a crane, use only the designated crane (fork lift) pockets **(B)**. Follow all crane operating instructions as indicated by the crane manufacturer.
- When using a forklift, use only the designated forklift pockets **(B)**. Follow all forklift operating instructions as indicated by the forklift manufacturer.
- Adjust rigging to keep the machine level and to minimize the risk of damage to machine.

NOTE: Only trained and authorized personnel should attempt to lift the aerial work platform using either a crane or forklift.

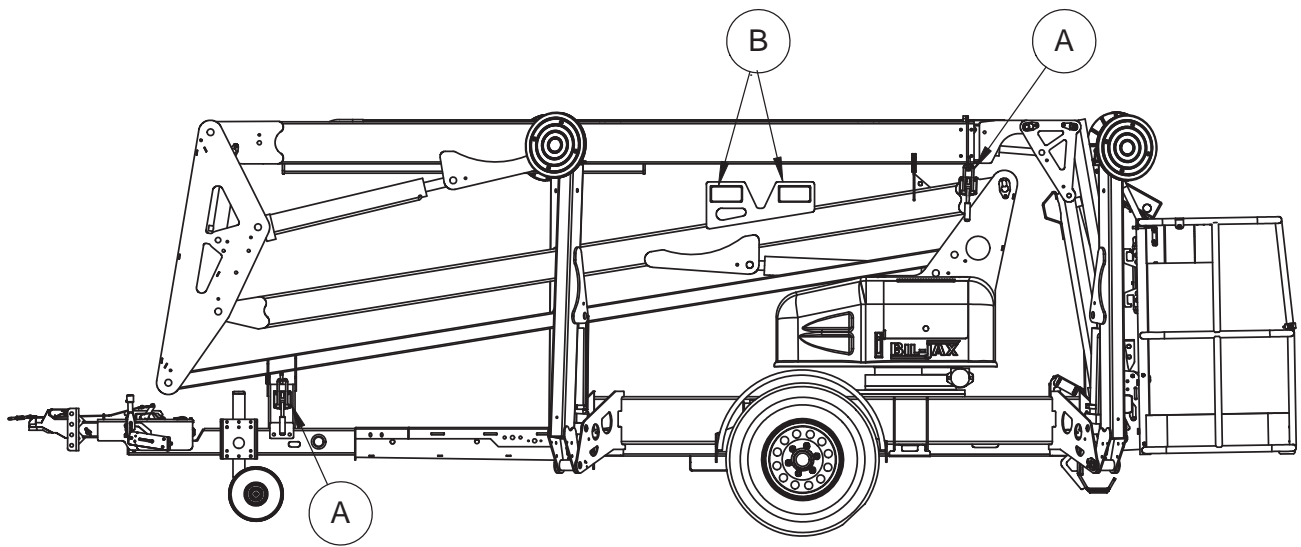

Figure 3-9. Lifting the Aerial Work Platform

TRANSPORTING THE AERIAL WORK PLATFORM ON A TRUCK BED

Refer to Figure 3-10.

- Verify that the truck or trailer is parked on a firm and level surface.
- Completely retract and lower all booms.
- Secure both **BOOM TRAVEL LATCHES**.
- Retract all **OUTRIGGER CYLINDERS** to the fully “stowed” (upright) position.
- Load boom onto the truck or trailer.
- Chock **(A)** the wheels and apply the **PARKING BRAKE**.
- Place a wooden block **(B)** under the **TONGUE**, near the **TRAILER HITCH**.
- Lower the **TONGUE JACK / DOLLY WHEEL (C)** until the **TRAILER TONGUE** rests on the wooden block. Swing up and lock the **TONGUE JACK / DOLLY WHEEL (C)** so that the weight of the **TONGUE** now rests on the wooden block.
- Secure the aerial work platform to the trailer bed using straps or chains. Use only the four attachment points **(D)** beneath the machine, adjacent to the outriggers.
- Adjust as necessary to prevent damage to rigging equipment or machine.

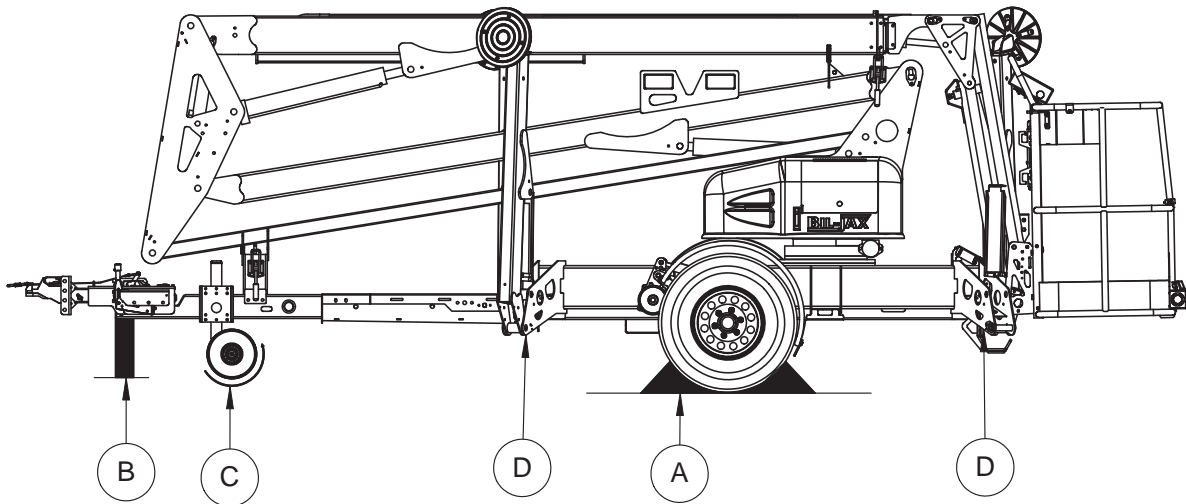

Figure 3-10. Transporting the Aerial Work Platform

4 EQUIPMENT MAINTENANCE

Performing the appropriate maintenance procedures will extend the life of the aerial work platform and will help ensure the safety of personnel operating the equipment.

Repair, replacement or adjustment of any hydraulic or electrical control device should be performed only by fully trained and authorized personnel. These include, but are not limited to, hydraulic load valves, hydraulic flow control valves, solenoid valves, and limit switches. These are safety related controls. Improper adjustment or tampering with these devices may impair aerial work platform function and result in safety or damage hazards.

Persons performing maintenance or repairs on the aerial work platform should be trained in accordance with the manufacturer's recommendations. Contact Haulotte Group Customer Service Department: at 1-800-537-0540 or visit Haulotte Group online at www.haulotte-usa.com if additional information is needed.

Critical or suspect areas identified during any scheduled inspection of the aerial work platform shall be examined by qualified personnel in accordance with all Federal, State, and Local codes and regulations that govern the safe operation of this equipment.

NEVER operate the aerial work platform if a defect or malfunction is identified or suspected. All defects and malfunctions must be repaired, and all maintenance performed, before returning an aerial work platform to service.

This manual contains a list of recommended maintenance procedures to be performed daily, weekly, monthly, and annually. Refer to it when inspecting this machine.

It is the practice of Haulotte Group to issue Service and / or Safety Bulletins, which may include updates to the information contained in this manual. In such instances, procedures contained in Haulotte Group Service or Safety Bulletins supersede the information contained in this manual.

ALWAYS follow the maintenance schedule, regardless of use.

BATTERY RECHARGE

Recharge aerial work platform batteries after each 8-hour work shift or as needed. When the aerial work platform is not in use, batteries should be recharged at least once per week. Under normal circumstances, battery recharge should take approximately 10-12 hours. However, a full recharge may take up to 24 hours, if the battery charge is extremely low.



WARNING

Recharge batteries in a well-ventilated area only. **DO NOT** charge batteries near fire, spark or other potential ignition sources. Batteries may emit highly explosive Hydrogen gas while charging. Failure to properly ventilate the charge gasses could result in death or serious injury. Always charge aerial work platform batteries away from flammable materials.

To recharge the aerial work platform batteries:

- Move the aerial work platform to a well-ventilated area with direct access to an AC electrical outlet. Keep the aerial work platform and batteries away from open flames or other potential ignition sources.
- Attach a 12 AWG multi-strand, grounded **EXTENSION CORD** with a maximum length of 50 feet (15 meters) to the receptacle located on the **GENERATOR INTERFACE PLATE** in front of the turntable.

NOTE: Using an underrated or long power cord will reduce the output of the battery charger and may extend charge time.

- Plug the **EXTENSION CORD** into outlet. Verify that the **GREEN CHARGING** indicator **LED** is lit on the **BATTERY CHARGER FACEPLATE**. Refer to Figure 4-1.
- The charging indicator **LED** remains lit continuously during the first stage of the charge cycle. The charge current will be displayed on the **BATTERY CHARGER FACEPLATE**.
- To display the Battery Voltage, press (push) in, and hold the **BATTERY VOLTAGE** button. Refer to Figure 4-1.

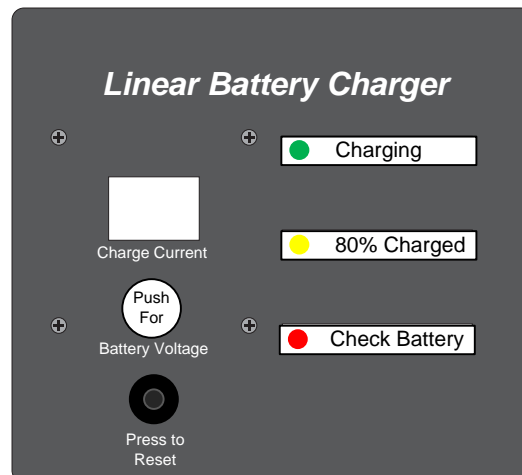



Figure 4-1. Battery Charger Faceplate

BATTERY RECHARGE (CONTINUED)

- If a battery fault is detected, a fault code will appear on the **CHARGE CURRENT** display. The red **CHECK BATTERY** indicator **LED** will become lit. Refer to Table 4-1 for battery charger fault codes.



WARNING

DO NOT disconnect any output leads or connectors between the batteries and the charger when the charger is on. To stop a charge in progress, always unplug the extension cord from the AC Power source.

- When the battery charge reaches 80% of capacity, the yellow “**80% CHARGED**” indicator **LED** will become lit and the “**GREEN CHARGING**” indicator **LED** will begin to flash.
- When the batteries have reached a full charge, the green and yellow indicator **LEDs** will turn themselves off. **CC** (Charge Complete) will appear on the **CHARGE CURRENT** display. After two hours, this display will fade and the **CHARGE CURRENT** will read 00.
- Unplug the **EXTENSION CORD** from the outlet and the charger receptacle on the aerial work platform. Store the **EXTENSION CORD** for next use.

BATTERY FAULT CODES

TABLE 4-1. BATTERY CHARGER FAULT CODES

Code	Description	Limits	Cause
F0	No Battery	<10 volts	Loose connection or battery missing
F1	Over Voltage	>112% charge voltage	Connected to wrong battery voltage
F2	Over Current	>60 amperes	Operating machine while charging
F3	Bulk Mode Timeout	<80% charge at 16 hrs.	Battery fault
F4	ARD Mode Timeout	>80% and <full charge after 6 hrs Max.	Battery fault
F9	Current Measurement Error Standby		Board fault or charger exposed to extreme cold
FA	Triac Error		Board shorted
FF	Full Power to Transformer, No Current Output		Battery shorted or low AC line voltage or charge fault
CO	Charger Off		Charger resting between pulses (AGM batteries only)
CC	Charge Mode Complete		Batteries charged

NOTICE

Always unplug the battery charger power cord before moving the aerial work platform. Failure to disconnect power cord could cause damage to the equipment.

DAILY SERVICE CHECKS

The following Maintenance Procedures should be performed daily or before each operation:

Verify that all decals are legible, correctly applied, and in plain view.

Refer to the “Decal Replacement” section of this manual for decal locations.

Verify that all controls and indicators at the ground (lower), and platform (upper) control stations operate properly.

- Lower outriggers to level the aerial work platform.
- Operate all boom functions, including all jib functions.
- Press (push) in the **EMERGENCY STOP** button. Verify that all functions are deactivated.
- Verify that the cylinders are functional and there is no internal leakage, an indication of this is that the booms would not remain elevated, and / or they may drift.
- Pull out the **EMERGENCY STOP** button, all functions will now be activated. Lower the booms.
- If either control panel is unresponsive, refer to the Trouble Shooting procedures.
TABLE 4-2 TROUBLE SHOOTING is located later in this section.
- If the **GROUND (LOWER) CONTROL DISPLAY PANEL** displays an error code, refer to the Control Panel Error Code definitions.
TABLE 4-3 ERROR CODE DEFINITIONS is located later in this section.
- If the **MOTOR CONTROLLER’S** green light is flashing there is an error, refer to the Motor Controller Error Code Definitions.
TABLE 4-4 ERROR CODE DEFINITIONS – MOTOR CONTROLLER, is located later in this section.
- If the aerial work platform has the Drive and Set option, operate the drive function from the platform (upper) control panel.

Verify correct operation of turn signals, brakes and running lights.

Verify proper tire inflation. See the side wall of the tire for proper inflation.

Inspect tires for damage or loose or missing lug nuts.

- Repair or replace as necessary.

Inspect structural components and platform for obvious damage or debris.

- Repair or replace as necessary.

Inspect the aerial work platform for missing, loose or damaged fasteners, including pins and bolts.

Verify that the boom / jib limit switches operate correctly.

- Limit switches are actuated when the primary, secondary and jib booms are in the fully lowered “stowed” position. Limit switches must be activated to raise or lower outriggers.
- If outrigger controls are unresponsive when the booms are fully lowered and “stowed”, inspect the limit switches for loose mountings or visible damage.
- Repair or replace as necessary.

DAILY SERVICE CHECKS (CONTINUED)

Verify that outrigger safety interlocks operate correctly.

- Begin with the outriggers fully extended and the aerial work platform leveled. Raise one outrigger until the footpad is **not** in contact with the ground.
- Verify that boom functions are unresponsive when one outrigger is raised.
- Repeat this procedure for each outrigger.
- Raise all outriggers until the footpads are **not** in contact with the ground. Verify that all outrigger status **LEDs** on the ground (lower) control panel are **unlit**.
- Lower one outrigger until the footpad makes contact with the ground and the outrigger begins lifting the trailer.
- If the **LED** is lit before the footpad makes contact with the ground or if the **LED** remains unlit after the weight is transferred to the outrigger, the position switch or wiring is faulty. Refer to Figure 4-2
- Repeat this procedure for each outrigger.
- Repair or replace as necessary.

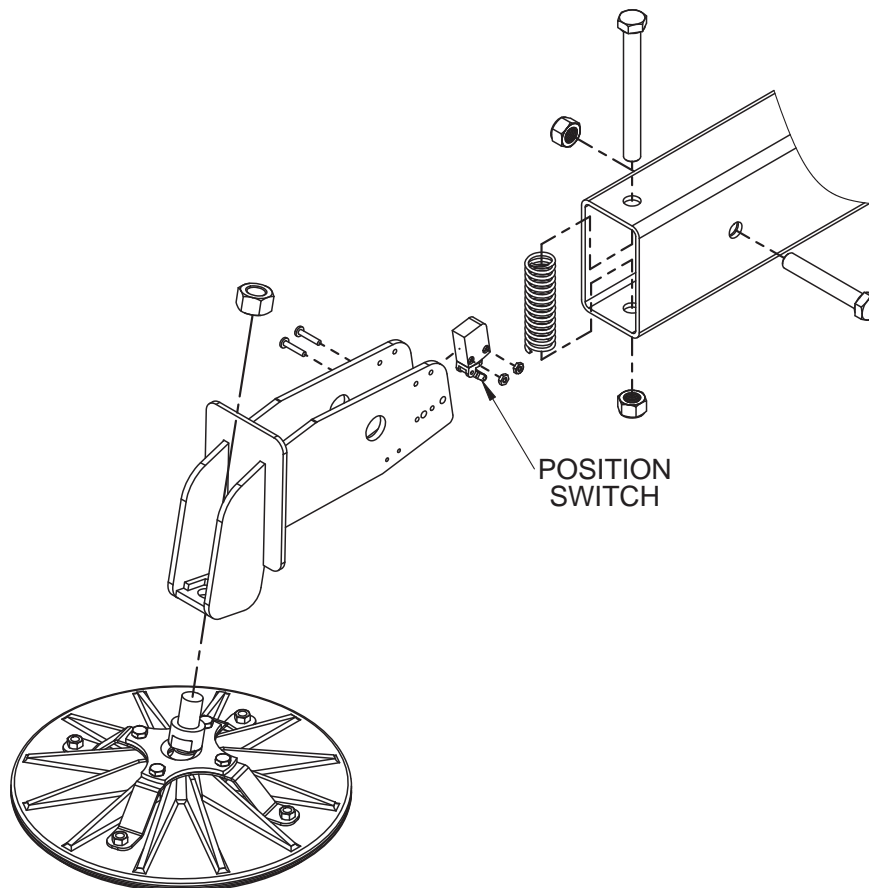

Figure 4-2. Outrigger Position Switch

DAILY SERVICE CHECKS (CONTINUED)

Inspect Hydraulic System and Fluid Levels.

- Check all hydraulic hoses and fittings for leaks and / or damage. Tighten or replace as necessary to prevent hydraulic oil or pressure loss.
- The hydraulic oil level should be checked with the booms down, all outriggers raised and in the “stowed” (upright) position, and the trailer wheels on a level surface.
- Hydraulic oil level should be visible in, but not above, the sight gauge.
- If the hydraulic oil level is not visible to at least half way up the sight gauge, add clean Hydraulic Fluid while all booms are in the “stowed” (down) position, and the outriggers are fully retracted and in the “stowed” (upright) position. Pour slowly to avoid creating air pockets in the reservoir. **DO NOT** fill above the sight gauge. Refer to Figure 4-3.
- Overfilling the hydraulic reservoir may cause damage to hydraulic lines and may result in aerial work platform malfunction.
- The hydraulic reservoir is originally filled with HVI AW32 Hydraulic Oil. A minimum Viscosity Index of 175 is recommended for this aerial lift platform.

NOTICE

DO NOT mix hydraulic oils. **DO NOT** add any fluid to the hydraulic system that is not expressly recommended by the manufacturer. Adding unauthorized fluids to the hydraulic system could cause damage to the aerial work platform.

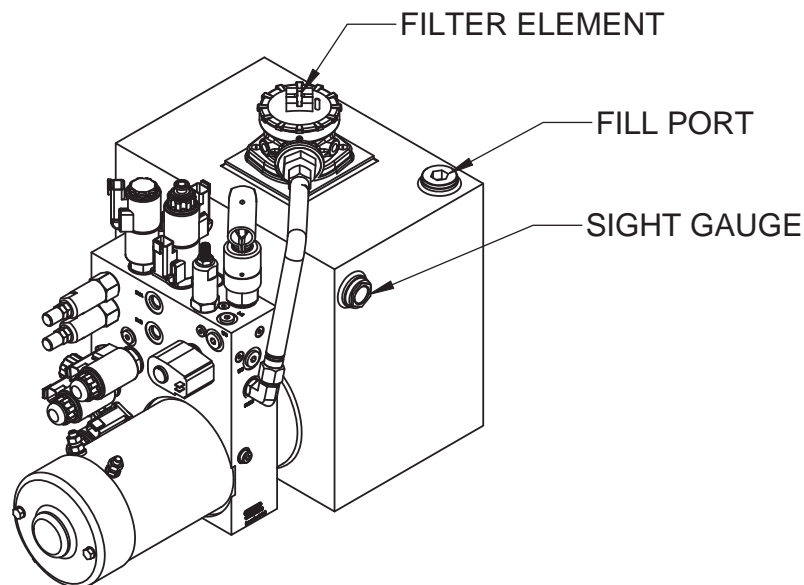

Figure 4-3. Hydraulic Reservoir

WEEKLY SERVICE CHECKS

Perform the following service checks at least once each week in addition to all recommended Daily Service Checks:

Check Battery Electrolyte level.

- If battery charge is low, add enough water to bring the electrolyte level to the top of the plates.
- If batteries are fully charged, raise electrolyte level to full mark in each cell.

Inspect all electrical wiring.

- Check for cuts, loose terminals, broken wires, chaffing and corrosion.
- Repair all damage, remove corrosion and seal with proper materials.

Inspect transport hitch components for damage. Applicable to trailer mounted aerial lift platforms only.

Inspect the aerial work platform for missing, loose or damaged hardware.

- Repair or replace as necessary.

Inspect all hydraulic system components including the pump, motor and cylinders for damage, leaks, loss of pressure or speed, and unusual noise or vibration.

- Repair or replace as necessary.

MONTHLY SERVICE CHECKS

Perform the following service checks at least once each month:

Check battery for loose connections or damaged wires.

Clean all battery terminals.

Verify proper operation of manual lowering valves and hand pump.

- For manual boom operating procedures, refer to the “Operation” section of this manual.

Lubricate slew ring and mating gear.

- Use NLGI Grade 2 multi-purpose grease.

Check wheel nut torque.

- Check for correct wheel nut tightening sequence. Refer to Figure 4-4.
- Evenly tighten wheel nuts to 25 lb-ft (34 N-m) in the tightening sequence shown.
- Repeat tightening sequence, tighten wheel nuts to 60 lb-ft (81 N-m) and then to 100 lb-ft (136 N-m).

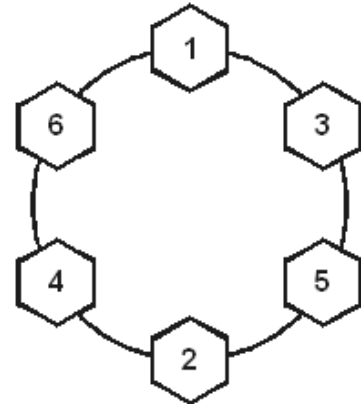

Figure 4-4. Wheel Nut Tightening Sequence

NOTICE

When wheels are newly installed or replaced, verify wheel nut torque monthly. Follow this procedure each time the wheel is removed and reinstalled. Improperly torqued wheel nuts could result in wheel separation, pre-mature tire wear, or damage to the equipment.

Check parking brakes.

Refer to the “Set up and Adjustment” section located in the “Axle and Related Components” section of this manual for more detailed information.

Verify that the Level Sensor is operating correctly.

- Fully deploy outriggers until all outrigger **LEDs** and **AUTO LEVEL LED**'s are lit, and the buzzer at the ground (lower) control panel sounds.
- Verify that the aerial work platform is level, and that the level sensor located on the control side of the turntable, is giving an accurate reading.
- Repair or replace as necessary.

For aerial work platforms with material hook option:

- Verify the weight reading displayed on the ground (lower) control panel is within 10% of actual weight tested. Recalibrate load cell if needed. Refer to the “Overload Protection Calibration” procedure located later in this section.

ANNUAL SERVICE CHECKS

Perform the following service checks at least once each year:

Replace Hydraulic Oil and Oil Filter.

- Wipe away dirt and excess oil from the area around the power unit, hoses and filter(s) using cleaning cloths and alcohol solvent.
- Drain reservoir by removing the hex plug located on the bottom side of the reservoir.
- After oil is drained, remove oil filter(s) from top of tank.
- Replace the filter being careful not to introduce any debris into the system. Do not over-tighten.
- Replace oil with HVI AW32 or equivalent Hydraulic oil with a minimum viscosity rating of 175.
- With the fill port cap on but not tightened, completely raise and lower the telescoping boom to bleed trapped air from the lift cylinders. Repeat as necessary.
- Repeat every 100 **RUN** hours, or annually, which ever comes first. Run hours are displayed by simultaneous pressing (pushing) the **RABBIT (2)** and the **TURTLE SPEED (3)** buttons on the ground (lower) control panel and reading the **DISPLAY PANEL (1)**. Refer to Figure 4-5.

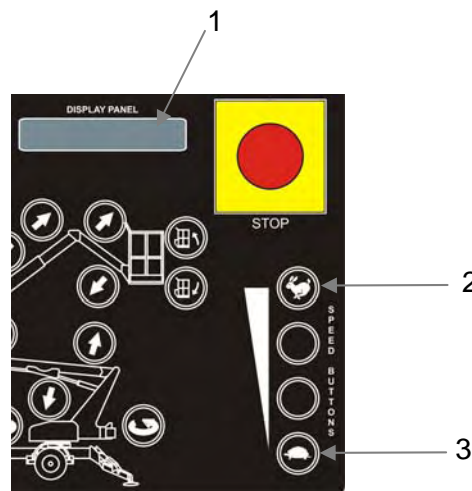

Figure 4-5. Display Run Time Hours

Inspect pivot pins and cylinders, including rod ends, for wear or damage. Replace as necessary.

Visually inspect welds and structural components for wear, damage and corrosion.

- Follow all manufacturers' recommendations when making repairs to critical components.
- Personnel making repairs to welds should be certified in accordance with the Structural Welding Code AWS D1 and Haulotte design standards.

Inspect outriggers for wear or damage. Repair or replace as necessary.

Inspect axle and adjust parking brakes as necessary.

- Refer to the "Axle and Related Components" section in the back of this manual for a partial reprint of the Dexter Operation Manual.

Load test telescoping boom lift operations with 500 lb (227 kg) load.

ANNUAL SERVICE CHECKS (CONTINUED)

Check slew bearing for wear or damage.

- Deploy the outriggers using the **AUTO LEVEL** and **EXTEND** buttons on the ground (lower) control panel. The tires will be slightly off the ground in this position.
- Place a 175 lb (65 kg) load in the platform and raise the **PRIMARY** boom to the full out position. Refer to Figure 4-6.

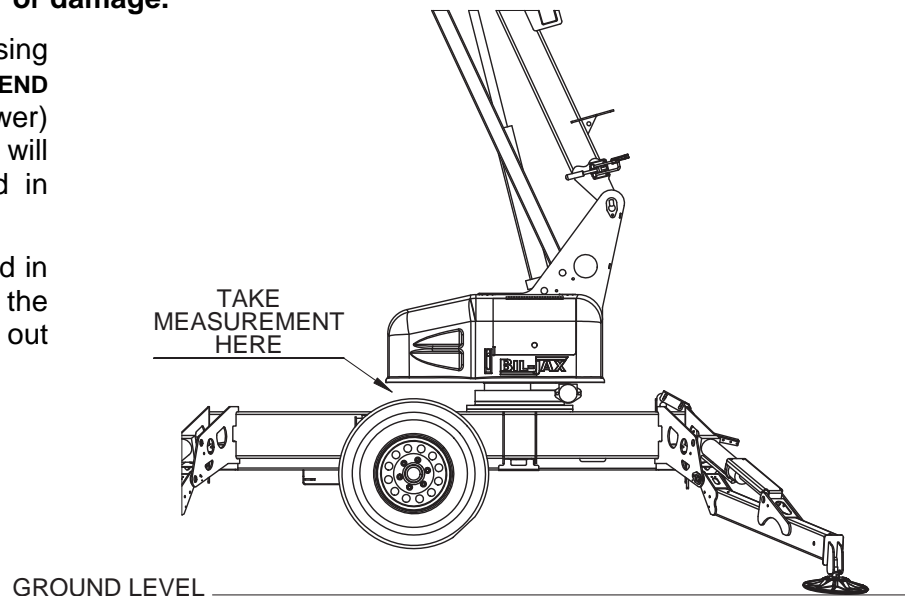

Figure 4-6. Machine Position for Slew Ring Measurement

- Measure the distance between the slew ring gear and the horizontal plate above, using a 2 in. (50 mm) caliper or bore micrometer. Refer to Figure 4-7.

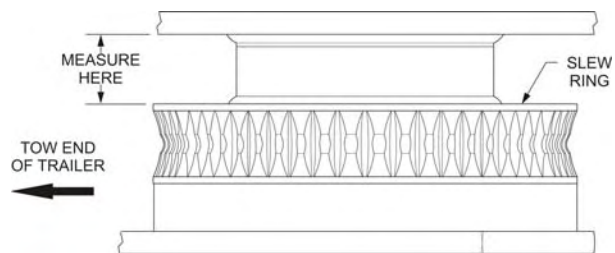

Figure 4-7. Slew Ring Position Measurement

- Record the measurement.
- Rotate the platform 180° and re-record the measurement. Refer to Figure 4-8.
- If the difference in measurements is greater than 0.25 in (6.35 mm) the slew ring bearing should be replaced. Contact Haulotte Group Customer Service Department: at 1-800-537-0540 or visit Haulotte Group online at www.haulotte-usa.com if additional information is needed.

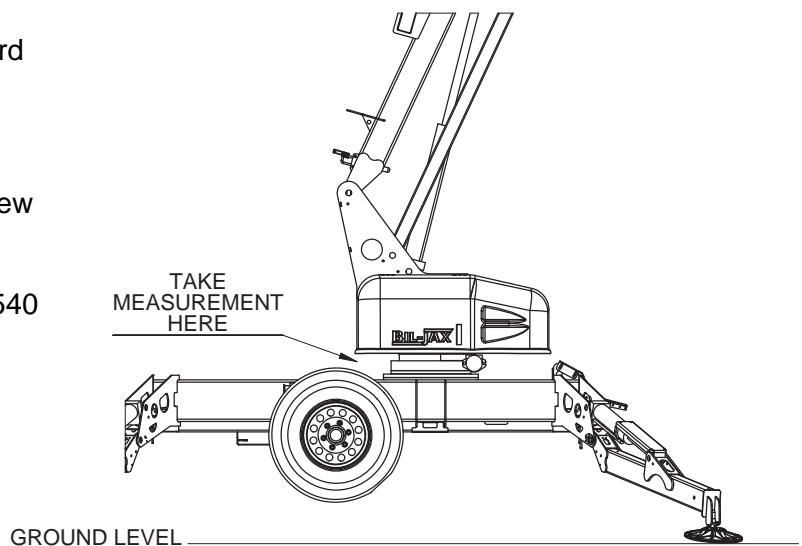

Figure 4-8. Platform Position after Rotation

STRUCTURAL INSPECTION

A comprehensive structural inspection of the unit shall be performed under any of the following conditions:

- Ten years from the date of manufacture and every five years thereafter.
- After any actual, suspected or potential damage is sustained that could affect the structural integrity or stability of the aerial work platform.
- After a change in ownership. Owners should provide a complete service history when reselling the unit. The structural inspection shall include the following considerations:
 - The service history of the unit, including hours of service, work performed and environmental conditions.
 - The inspection and maintenance record of the aerial work platform.
 - The effectiveness of all controls and components.
 - A visual inspection of the aerial work platform for wear or damage.
 - Manufacturer recommendations.
 - A visual weld inspection, to be performed by qualified personnel in accordance with the Structural Welding Code AWS D1 and Haulotte design standards.

MOTOR DRYING INSTRUCTIONS

Inclusion of water or foreign particles into the DC electric motor housing may cause serious damage to the motor. If the motor becomes wet, follow these instructions or contact an authorized Haulotte Group service technician

- Remove brush cover band.
- Blow warm air into motor using a heat gun.
- Spray electrical contact cleaner solution into motor armature area.
- Replace brush cover band.

LEVELING SYSTEM CALIBRATION PROCEDURE

Machine Leveling Instructions

Deploy all of the outriggers, and slightly raise the base of the machine to position it for leveling. Refer to Figure 4-9.

Place a small, standard “level” on the base of the turntable (Level Placement Option A). If a small “level” is not available, place any size, standard “level” on the base of the machine (Level Placement Option B). Using the outriggers individually, level the base of the machine.

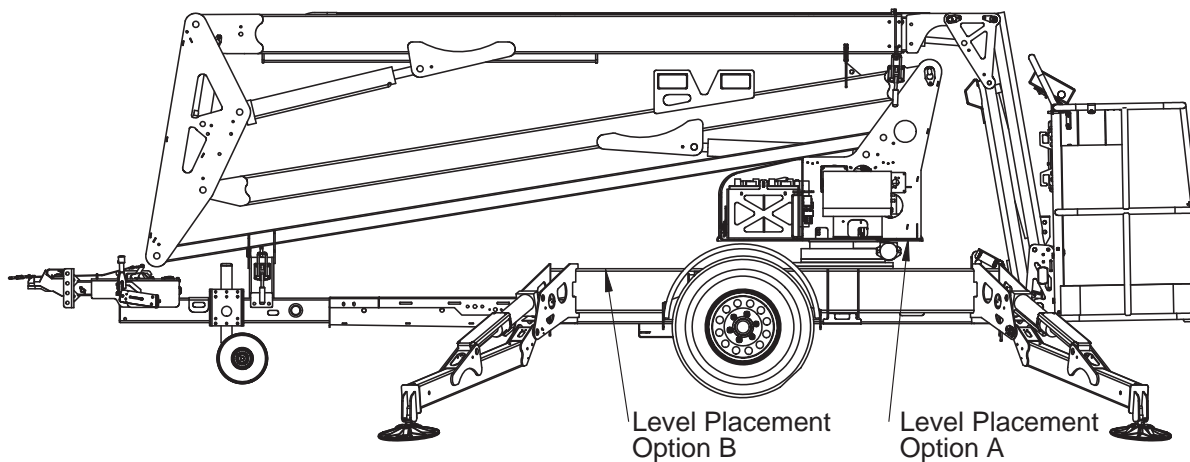

Figure 4-9. Position Machine for Leveling

Level Sensor Calibration Instructions



Figure 4-10. Level Sensor

If your level sensor resembles the image in **Figure 4-10**, follow these instructions. Be aware that the LED's on the top of the sensor will need to be observed, the “Max Tilt Level Exceeded” LED is red, and the “TILT OK” LED is green.

- Press (push) and hold the **SET ZERO** button, located on the rear of the sensor, for 5 seconds. Both LED's will begin to flash.
- While they are flashing, release the **SET ZERO** button, and press (push) again 3 times within the next 5 seconds.
- When both LED's are “ON SOLID”, this indicates that the sensor “recognizes” this level position.
- Proceed to the “Ground (Lower) Control Box Calibration Instructions”.



Figure 4-11. Level Sensor

If your level sensor resembles the image in **Figure 4-11**, follow these instructions. Be aware that the “Bubble Level” on the top of the sensor will need to be observed.

- Using the nuts on the top of sensor adjust the sensor until the bubble is centered in the smallest circle.
- Proceed to the “Ground (Lower) Control Box Calibration Instructions”.

LEVELING SYSTEM CALIBRATION PROCEDURE (CONTINUED)

Ground (Lower) Control Box Calibration Instructions

Use the ground (lower) control panel to access the control box maintenance menu. Refer to Figure 4-12

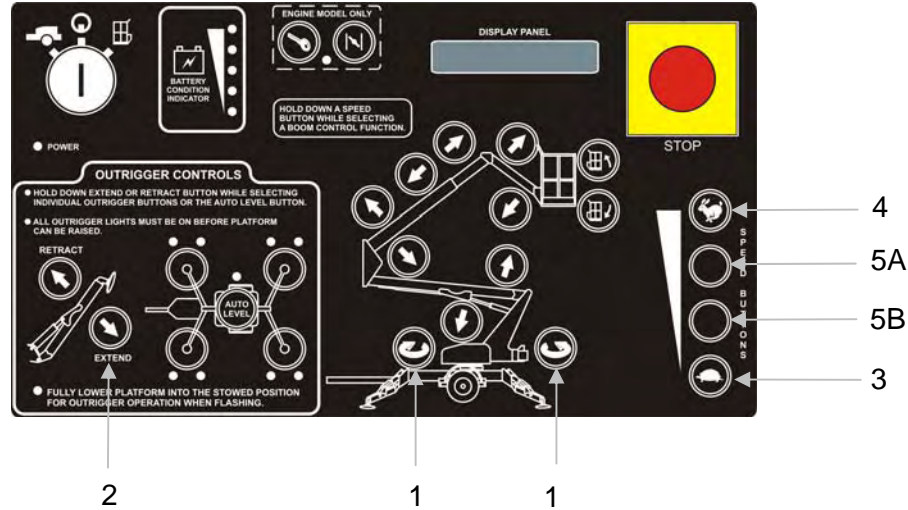

Figure 4-12. Ground (Lower) Control Panel for Leveling System

- 1) Enter the maintenance mode by pressing (pushing) both **ROTATE (1)** buttons and the **OUTRIGGER EXTEND (2)** button on the ground (lower) control panel simultaneously and holding for 5 seconds.
- 2) Scroll through the maintenance menu using the **TURTLE (3)** button to scroll down, use the **RABBIT (4)** button to scroll back up, until "Calibration Level Sensor" is found.
- 3) Press (push) both **MID SPEED** buttons **MID-HIGH (5A) / MID-LOW (5B)** on the ground (lower) control panel simultaneously. Three consecutive beeps will sound indicating the calibration is confirmed.
- 4) Exit the maintenance mode by scrolling through the menu using either the **TURTLE (3)** button, or the **RABBIT (4)** button.

OVERLOAD PROTECTION CALIBRATION PROCEDURE

- 1) Remove the **CLEVIS PIN** securing the **PLATFORM** to the **PLATFORM MOUNTING BRACKET**, allowing the **PLATFORM** to pivot about the **PLATFORM PIN** and rest on the ground. This removes the load from the **LOAD CELL**.
Refer to Figure 4-13.

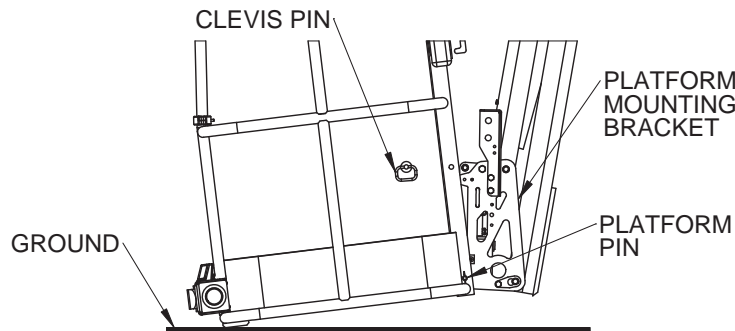

Figure 4-13. Platform Position

Use the ground (lower) control panel to access the control box maintenance menu.
Refer to Figure 4-14.

- 2) Enter the maintenance mode by pressing (pushing) both **ROTATE (1)** buttons and the **OUTRIGGER EXTEND (2)** button on the ground (lower) control panel simultaneously and holding for 5 seconds.

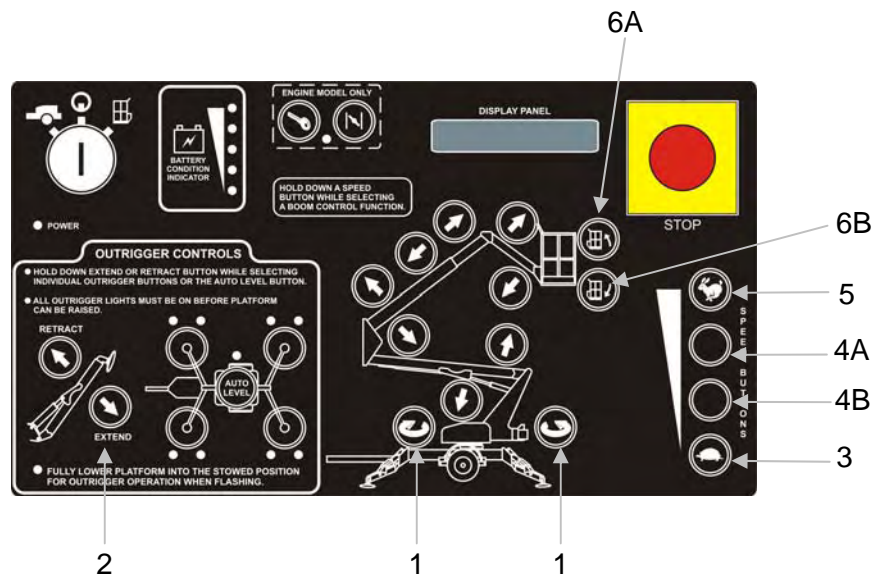

Figure 4-14. Ground (Lower) Control Panel for Overload Protection

- 3) Scroll through the maintenance menu using the **TURTLE (3)** button to scroll down, use the **RABBIT (5)** button to scroll back up, until "Load Sense Zero Calibration Utility" is found.
- 4) Press (push) both **MID SPEED** buttons **MID-HIGH (4A)** / **MID-LOW (4B)** on the ground (lower) control panel simultaneously. Three consecutive beeps will sound and the display will read "Load Sense Has Been Zero Calibrated" confirming the operation. The maintenance mode will then go to "Load Sense Scaling Utility".

OVERLOAD PROTECTION CALIBRATION PROCEDURE (CONTINUED)

- 5) In “Load Sense Scaling Utility”, the display should read a ratio of “3.68:1=0”. If the ratio is not “3.68:1”, proceed to Step 6. If the ratio is correct, but load is not “=0”, skip Step 6 and proceed to Step 7. If both the ratio and the load are correct, proceed to Step 8.
- 6) If the ratio is not “3.68:1”, press (push) the **MID-HIGH (4A) / MID-LOW (4B) SPEED** button until the ratio is correct. Proceed to Step 7.
- 7) Press (push) the **RABBIT (5)** button to return to “Load Sense Zero Calibration Utility” and repeat Steps 4 and 5. The Display should now read “3.68:1=0”. If so, proceed to Step 8.
- 8) Exit the maintenance mode by scrolling through the menu using the **TURTLE (3)** button.
- 9) Press (push) the **PLATFORM TILT UP (6A)** button and **PLATFORM TILT DOWN (6B)** button simultaneously until the display reads “Boom Load=0000 lbs/kg”.
- 10) Return the platform to the upright position and re-install the clevis pin. Press (push) the **PLATFORM TILT UP (6A)** button, and the **PLATFORM TILT DOWN (6B)** button simultaneously to visualize the display, it should now read 65lbs/30kg ($\pm 10\%$).

NOTE: For lifts with the Platform Rotate option, the display should read 125lbs/57kg.

- 11) Add between 350-400lbs / 159-182kg to platform.

NOTE: Keep accurate track of how much weight (within ± 5 lbs/2.3kg) is added to the platform.

- 12) The “Boom Load” on the display should read the added weight plus the initially displayed weight against the load cell, this weight needs to be within $\pm 10\%$. To determine the percentage use the formulas below, where **W1** is the platform only weight and **W2** is the weight that was added to the platform.

<p>Minimum Load = $0.9 (W1 + W2)$</p> <p>Maximum Load = $1.1 (W1 + W2)$</p>

- 13) If the displayed load is within tolerances, proceed to Step 14. If not, return to the maintenance mode, scroll **PAST** “Load Sense Zero Calibration Utility” and proceed directly to “Load Sense Scaling Utility”.
- 14) Adjust displayed weight by pressing (pushing) the **MID-HIGH (4A)** or **MID-LOW (4B) SPEED** buttons until the weight is within tolerances. Exit the maintenance mode. The Ratio should be within **3.50:1** to **4.00:1**. If so, continue on to Step 15. If the ratio is **not** within the above values, contact Haulotte Group Customer Service Department: at 1-800-537-0540 or visit Haulotte Group online at www.haulotte-usa.com.
- 15) Remove the weight from the platform. The Boom Load should now return to the initially displayed weight from Step 9.
- 16) Operate all functions in all speeds from both the ground (lower) and platform (upper) control panels to verify proper operation.
- 17) Recalibration is complete.

ADDITIONAL SERVICE INFORMATION

Seals on hydraulic cylinders should be replaced every five years or as indicated by aerial work platform performance.

All service checks should be performed on an aerial work platform that has been stored without use for a period exceeding thirty (30) days.

Check for air in the hydraulic system if the aerial work platform has been stored without use for a period exceeding thirty (30) days, or if the aerial work platform was stored without use during a seasonal climate change. Air trapped in the hydraulic system will affect aerial work platform performance. Follow procedures for bleeding air from the hydraulic system, found in the "Cylinder Replacement" section of this manual.

Owners and lessors should complete a full inspection of all components and perform a test of all functions, including brake functions, before commissioning or reselling the aerial work platform. Always repair or replace all damaged or malfunctioning components before commissioning or reselling an aerial work platform.

When a change in ownership occurs, it is the responsibility of the seller to provide the new owner with all manuals for the aerial work platform. It is the responsibility of the buyer to notify the manufacturer of the unit model and serial number and the name and address of the new owner within sixty (60) days of the purchase.

Use the service checklists found at the back of this manual to record all service checks as well as any maintenance, repairs or alterations performed on the aerial work platform.

Records of frequent safety checks need not be made. However, where a safety hazard is found, it shall be reported in writing to the owner of the aerial work platform, and a record of any corrective action shall be maintained for five years or as required by the authority having jurisdiction.

TROUBLESHOOTING

Refer to the following Table for basic Troubleshooting Operations. Contact Haulotte Group Customer Service Department: at 1-800-537-0540 or visit Haulotte Group online at www.haulotte-usa.com with any questions, or before attempting any advanced troubleshooting operations.

TABLE 4-2. TROUBLE SHOOTING

PROBLEM	CAUSE	SOLUTION
No lights on panel when key switch is turned to the on position.	<ul style="list-style-type: none"> a. EMERGENCY STOP engaged. b. Battery charge is low. c. Battery ground or in-series cable is loose. d. Battery main disconnect unplugged. e. Blown Fuse 	<ul style="list-style-type: none"> a. Disengage EMERGENCY STOP buttons. b. Recharge as needed. c. Inspect and repair battery connections. d. Plug in main disconnect. e. Replace Fuse as necessary.
Error code displayed on Ground Control Panel.	<ul style="list-style-type: none"> a. Error detected by Control Box. 	<ul style="list-style-type: none"> a. Refer to Error Code Definitions, Table 4-3.
Green light flashing on Motor Controller.	<ul style="list-style-type: none"> a. Error detected by Motor Controller. 	<ul style="list-style-type: none"> a. Refer to Motor Controller Error Code Definitions, Table 4-4.
Hydraulic function does not work and display window shows an error message.	<ul style="list-style-type: none"> a. Error detected by safety interlock microprocessor. b. Aerial work platform electric or electronic failure. 	<ul style="list-style-type: none"> a. Refer to error code definitions, Table 4-3. b. Refer to error code definitions, Table 4-3.
Outrigger indicator LED lights do not function.	<ul style="list-style-type: none"> a. Key switch turned to the OFF or platform controls position. b. EMERGENCY STOP engaged. c. Outriggers not deployed. 	<ul style="list-style-type: none"> a. Turn key switch to ground controls position. b. Disengage EMERGENCY STOP buttons. c. Deploy all outriggers.
<p>One or more Boom Controls, are not functioning.</p> <p>OR</p> <p>One or more Boom Controls, functions improperly.</p> <p>OR</p> <p>One or more Boom Controls, functions intermittently.</p>	<ul style="list-style-type: none"> a. Key switch is turned to the OFF or incorrect control position. b. Battery charge is low. c. EMERGENCY STOP engaged. d. Battery ground or in-series cable loose. e. All outriggers not properly deployed. f. Hydraulic pump inoperative. g. Loose wiring connector. h. Valve solenoid not operating properly. i. Error detected by system interlock. j. Broken or loose wire. 	<ul style="list-style-type: none"> a. Turn key switch to ground or platform controls position. b. Recharge battery. c. Disengage EMERGENCY STOP buttons. d. Inspect and repair battery connections. e. Deploy all outriggers and level aerial work platform. f. Inspect pump; replace or repair as needed. g. Check wiring terminals in control box and at valve manifold; replace or repair as needed. h. Clean valve solenoid and recheck function(s); replace or repair as needed. i. Check display for system status. Refer to Table 4-3 for error code definitions and correction. j. Inspect wiring in control box and at valve manifold and valve coil; repair or replace as needed.

ERROR CODE DEFINITIONS – CONTROLS

The **DISPLAY PANEL** located on the ground (lower) control panel, indicates the present operating status of the aerial work platform. If an error condition is detected, the appropriate error code will be displayed on this panel.

Refer to Table 4-3 to resolve the error, or contact Haulotte Group Customer Service Department: at 1-800-537-0540 or visit Haulotte Group online at www.haulotte-usa.com with any additional questions.

TABLE 4-3. ERROR CODE DEFINITIONS

ERROR MESSAGE	ERROR DEFINITION	TO SIMULATE ERROR	TO CLEAR ERROR	COMMENTS
001 MACHINE IS IN DOWN ONLY MODE	Machine went out of level with use, moment sense or load sense circuits have detected an overload	Level machine, raise boom and tilt level sensor	This is a self clearing error. When error condition is corrected, error is cleared	Error will be displayed only if boom is raised
002 LOSS OF PLATFORM COMMUNICATION	Lower Control has lost RS485 communication with Platform Control	Open Platform Control and remove green wire from J1	This is a latched error. Power must be cycled to clear error	The Platform Control "Engine On" LED will also blink a 2 blink error code.
003 LOSS OF DRIVE COMMUNICATION	Lower Control has lost RS485 communication with Drive Control	Open Drive Control and remove green wire from J1	This is a latched error. Power must be cycled to clear error	Machines with Drive option only. The Drive Control "Engine On" LED will also blink a 2 blink error code.
004 LOSS OF PC COMMUNICATION	Lower Control has lost RS232 communication with PC	Connect a PC without running the configuration program	This is a self clearing error. When error condition is corrected, error is cleared	Error message will only be display if connected to a PC that is not communicating.
005 PLATFORM CONTROL HAS STUCK KEY	Platform Control has detected a stuck or pressed key on power up	On Platform Control hold down a key at power up	This is a latched error. Power must be cycled to clear error	The Platform Control "Engine On" LED will also blink a 1 blink error code.
006 DRIVE CONTROL HAS STUCK KEY	Drive Control has detected a stuck or pressed key on power up	On Drive Control hold down a key at power up	This is a latched error. Power must be cycled to clear error	Machines with Drive option only. The Drive Control "Engine On" LED will also blink a 1 blink error code.
007 DRIVE CONTROL HAS STUCK JOYSTICK	Drive Control has detected a stuck or pressed joystick on power up	On Drive Control hold joystick to side at power up	This is a latched error. Power must be cycled to clear error	Machines with Drive option only. The Drive Control "Engine On" LED will also blink a 3 blink error code.
008 GROUND CONTROL HAS STUCK KEY	Lower Control has detected a stuck or pressed key on power up	On Lower Control hold down a key at power up	This is a latched error. Power must be cycled to clear error	The Lower Control "Power" LED will also blink a 1 blink error code.
009 BOOM UP WITHOUT OUTRIGGERS ON GROUND	Lower Control has detected the boom is up and all four outriggers are not on the ground	Disconnect a wire from either the boom down or any outrigger switch and turn on machine	This is a self clearing error. When error condition is corrected, error is cleared	
010 LEVEL SENSOR HAS ERRATIC OUTPUT	The Lower Control has detected an erratic output from the level sensor	Shaking the level sensor after machine has been leveled	This is a self clearing error. When error condition is corrected, error is cleared	This error is suppressed during extending and retracting outriggers
011 TRYING TO DRIVE W/ TRAILER BRAKE OFF	An attempt was made to drive machine without engaging the trailer brake	Trying to drive machine with trailer brake off	This is a self clearing error. When error condition is corrected, error is cleared	Machines with Drive and Set option only
012 ANGLE SENSOR IS DISCONNECTED OR BAD	Angle sensor output is out of range	Disconnect Angle Sensor	This is a self clearing error. When error condition is corrected, error is cleared	Machines with Moment Sense option only

TABLE 4-3. ERROR CODE DEFINITIONS

ERROR MESSAGE	ERROR DEFINITION	TO SIMULATE ERROR	TO CLEAR ERROR	COMMENTS
013 PRESSURE SENSOR IS DISCONNECTED OR BAD	Pressure sensor output is out of range	Disconnect Pressure Sensor	This is a self clearing error. When error condition is corrected, error is cleared	Machines with Moment Sense option only
014 CHECK ENGINE LOW OIL PRESSURE	Engine had low oil pressure while running	Kawasaki Engine: While engine is running, disconnect engine oil pressure sense wire Kubota Engine: While engine is running, disconnect engine oil pressure sense wire and connect wire to ground	This is a latched error. Power must be cycled to clear error	X-Boom Machines with Kawasaki or Kubota engines
015 MACHINE IS NOT LEVEL	Machine has gone out of level with use	Tilt level sensor	This is a self clearing error. When error condition is corrected, error is cleared	
016 LIFT BOOM	A Boom Rotate, Extend or Retract function has been requested while boom is down	Try to Rotate, Extend or Retract the boom while boom is down	This is a self clearing error. When error condition is corrected, error is cleared	
017 STOW BOOM	An Outrigger function has been requested while boom is up	Try to move an outrigger while boom is up	This is a self clearing error. When error condition is corrected, error is cleared	
018 LOSS OF LOAD SENSE COMMUNICATION	Lower Control has lost RS485 communication with Load Sense Module	Remove Load Sense Module from machine	This is a latched error. Power must be cycled to clear error	Machines with Load Sense option only
019 BOOM FUNCTION DISABLED	Load Sense Module has detected an overloaded boom and disabled boom functions	Overload Boom	This is a latched error. Power must be cycled to clear error	Machines with Load Sense option only
020 LOSS OF LOAD CELL CONNECTION	Load Sense Module has lost connection with Load Cell	Disconnect Load Cell from Load Sense Module	This is a self clearing error. When error condition is corrected, error is cleared	Machines with Load Sense option only
021 OPEN CIRCUIT PRIMARY UP	A load of less than 70mA was detected when Primary Up circuit was energized	Disconnect a wire from Primary Up coil	This is a latched error. Power must be cycled to clear error	Checked only at power up
022 SHORTED CIRCUIT PRIMARY UP	Excessive load was detected when Primary Up circuit was energized	Use a piece of wire to short the Primary Up coil	This is a latched error. Power must be cycled to clear error	Checked only at power up
023 OPEN CIRCUIT PRIMARY DOWN	A load of less than 70mA was detected when Primary Down circuit was energized	Disconnect a wire from Primary Down coil	This is a latched error. Power must be cycled to clear error	Checked only at power up Articulating Boom Models
024 SHORTED CIRCUIT PRIMARY DOWN	Excessive load was detected when Primary Down circuit was energized	Use a piece of wire to short the Primary Down coil	This is a latched error. Power must be cycled to clear error	Checked only at power up Articulating Boom Models
025 OPEN CIRCUIT SECONDARY UP	A load of less than 70mA was detected when Secondary Up circuit was energized	Disconnect a wire from Secondary Up coil	This is a latched error. Power must be cycled to clear error	Checked only at power up Articulating Boom Models
026 SHORTED CIRCUIT SECONDARY UP	Excessive load was detected when Secondary Up circuit was energized	Use a piece of wire to short the Secondary Up coil	This is a latched error. Power must be cycled to clear error	Checked only at power up Articulating Boom Models

TABLE 4-3. ERROR CODE DEFINITIONS

ERROR MESSAGE	ERROR DEFINITION	TO SIMULATE ERROR	TO CLEAR ERROR	COMMENTS
027 OPEN CIRCUIT SECONDARY DOWN	A load of less than 70mA was detected when Secondary Down circuit was energized	Disconnect a wire from Secondary Down coil	This is a latched error. Power must be cycled to clear error	Checked only at power up Articulating Boom Models
028 SHORTED CIRCUIT SECONDARY DOWN	Excessive load was detected when Secondary Down circuit was energized	Use a piece of wire to short the Secondary Down coil	This is a latched error. Power must be cycled to clear error	Checked only at power up Articulating Boom Models
029 OPEN CIRCUIT JIB UP	A load of less than 70mA was detected when Jib Up circuit was energized	Disconnect a wire from Jib Up coil	This is a latched error. Power must be cycled to clear error	Checked only at power up Articulating Boom Models
030 SHORTED CIRCUIT JIB UP	Excessive load was detected when Jib Up circuit was energized	Use a piece of wire to short the Jib Up coil	This is a latched error. Power must be cycled to clear error	Checked only at power up Articulating Boom Models
031 OPEN CIRCUIT JIB DOWN	A load of less than 70mA was detected when Jib Down circuit was energized	Disconnect a wire from Jib Down coil	This is a latched error. Power must be cycled to clear error	Checked only at power up Articulating Boom Models
032 SHORTED CIRCUIT JIB DOWN	Excessive load was detected when Jib Down circuit was energized	Use a piece of wire to short the Jib Down coil	This is a latched error. Power must be cycled to clear error	Checked only at power up Articulating Boom Models
033 OPEN CIRCUIT EXTEND	A load of less than 70mA was detected when Extend circuit was energized	Disconnect a wire from Extend coil	This is a latched error. Power must be cycled to clear error	Checked only at power up
034 SHORTED CIRCUIT EXTEND	Excessive load was detected when Extend circuit was energized	Use a piece of wire to short the Extend coil	This is a latched error. Power must be cycled to clear error	Checked only at power up
035 OPEN CIRCUIT RETRACT	A load of less than 70mA was detected when Retract circuit was energized	Disconnect a wire from Retract coil	This is a latched error. Power must be cycled to clear error	Checked only at power up
036 SHORTED CIRCUIT RETRACT	Excessive load was detected when Retract circuit was energized	Use a piece of wire to short the Retract coil	This is a latched error. Power must be cycled to clear error	Checked only at power up
037 OPEN CIRCUIT PLATFORM LEVEL UP	A load of less than 70mA was detected when Platform Level Up circuit was energized	Disconnect a wire from Platform Level Up coil	This is a latched error. Power must be cycled to clear error	Checked only at power up
038 SHORTED CIRCUIT PLATFORM LEVEL UP	Excessive load was detected when Platform Level Up circuit was energized	Use a piece of wire to short the Platform Level Up coil	This is a latched error. Power must be cycled to clear error	Checked only at power up
039 OPEN CIRCUIT PLATFORM LEVEL DOWN	A load of less than 70mA was detected when Platform Level Down circuit was energized	Disconnect a wire from Platform Level Down coil	This is a latched error. Power must be cycled to clear error	Checked only at power up
040 SHORTED CIRCUIT PLATFORM LEVEL DOWN	Excessive load was detected when Platform Level Down circuit was energized	Use a piece of wire to short the Platform Level Down coil	This is a latched error. Power must be cycled to clear error	Checked only at power up
041 OPEN CIRCUIT PLATFORM CW	A load of less than 70mA was detected when Platform CW circuit was energized	Disconnect a wire from Platform CW coil	This is a latched error. Power must be cycled to clear error	Checked only at power up Articulating Boom Models
042 SHORTED CIRCUIT PLATFORM CW	Excessive load was detected when Platform CW circuit was energized	Use a piece of wire to short the Platform CW coil	This is a latched error. Power must be cycled to clear error	Checked only at power up Articulating Boom Models

TABLE 4-3. ERROR CODE DEFINITIONS

ERROR MESSAGE	ERROR DEFINITION	TO SIMULATE ERROR	TO CLEAR ERROR	COMMENTS
043 OPEN CIRCUIT PLATFORM CCW	A load of less than 70mA was detected when Platform CCW circuit was energized	Disconnect a wire from Platform CCW coil	This is a latched error. Power must be cycled to clear error	Checked only at power up Articulating Boom Models
044 SHORTED CIRCUIT PLATFORM CCW	Excessive load was detected when Platform CCW circuit was energized	Use a piece of wire to short the Platform CCW coil	This is a latched error. Power must be cycled to clear error	Checked only at power up Articulating Boom Models
045 OPEN CIRCUIT TURNTABLE CW	A load of less than 70mA was detected when Turntable CW circuit was energized	Disconnect a wire from Turntable CW coil	This is a latched error. Power must be cycled to clear error	Checked only at power up
046 SHORTED CIRCUIT TURNTABLE CW	Excessive load was detected when Turntable CW circuit was energized	Use a piece of wire to short the Turntable CW coil	This is a latched error. Power must be cycled to clear error	Checked only at power up
047 OPEN CIRCUIT TURNTABLE CCW	A load of less than 70mA was detected when Turntable CCW circuit was energized	Disconnect a wire from Turntable CCW coil	This is a latched error. Power must be cycled to clear error	Checked only at power up
048 SHORTED CIRCUIT TURNTABLE CCW	Excessive load was detected when Turntable CCW circuit was energized	Use a piece of wire to short the Turntable CCW coil	This is a latched error. Power must be cycled to clear error	Checked only at power up
049 OPEN CIRCUIT OUTRIGGER RETRACT	A load of less than 70mA was detected when Outrigger Retract circuit was energized	Disconnect a wire from Outrigger Retract coil	This is a latched error. Power must be cycled to clear error	Checked only at power up
050 SHORTED CIRCUIT OUTRIGGER RETRACT	Excessive load was detected when Outrigger Retract circuit was energized	Use a piece of wire to short the Outrigger Retract coil	This is a latched error. Power must be cycled to clear error	Checked only at power up
051 OPEN CIRCUIT OUTRIGGER EXTEND	A load of less than 70mA was detected when Outrigger Extend circuit was energized	Disconnect a wire from Outrigger Extend coil	This is a latched error. Power must be cycled to clear error	Checked only at power up
052 SHORTED CIRCUIT OUTRIGGER EXTEND	Excessive load was detected when Outrigger Extend circuit was energized	Use a piece of wire to short the Outrigger Extend coil	This is a latched error. Power must be cycled to clear error	Checked only at power up
053 OPEN CIRCUIT LF OUTRIGGER	A load of less than 70mA was detected when LF Outrigger circuit was energized	Disconnect a wire from LF Outrigger coil	This is a latched error. Power must be cycled to clear error	Checked only at power up
054 SHORTED CIRCUIT LF OUTRIGGER	Excessive load was detected when LF Outrigger circuit was energized	Use a piece of wire to short the LF Outrigger coil	This is a latched error. Power must be cycled to clear error	Checked only at power up
055 OPEN CIRCUIT RF OUTRIGGER	A load of less than 70mA was detected when RF Outrigger circuit was energized	Disconnect a wire from RF Outrigger coil	This is a latched error. Power must be cycled to clear error	Checked only at power up
056 SHORTED CIRCUIT RF OUTRIGGER	Excessive load was detected when RF Outrigger circuit was energized	Use a piece of wire to short the RF Outrigger coil	This is a latched error. Power must be cycled to clear error	Checked only at power up
057 OPEN CIRCUIT LR OUTRIGGER	A load of less than 70mA was detected when LR Outrigger circuit was energized	Disconnect a wire from LR Outrigger coil	This is a latched error. Power must be cycled to clear error	Checked only at power up

TABLE 4-3. ERROR CODE DEFINITIONS

ERROR MESSAGE	ERROR DEFINITION	TO SIMULATE ERROR	TO CLEAR ERROR	COMMENTS
058 SHORTED CIRCUIT LR OUTRIGGER	Excessive load was detected when LR Outrigger circuit was energized	Use a piece of wire to short the LR Outrigger coil	This is a latched error. Power must be cycled to clear error	Checked only at power up
059 OPEN CIRCUIT RR OUTRIGGER	A load of less than 70mA was detected when RR Outrigger circuit was energized	Disconnect a wire from RR Outrigger coil	This is a latched error. Power must be cycled to clear error	Checked only at power up
060 SHORTED CIRCUIT RR OUTRIGGER	Excessive load was detected when RR Outrigger circuit was energized	Use a piece of wire to short the RR Outrigger coil	This is a latched error. Power must be cycled to clear error	Checked only at power up
061 OPEN CIRCUIT ENGINE THROTTLE	A load of less than 70mA was detected when Engine Throttle circuit was energized	Disconnect a wire from Engine Throttle coil	This is a latched error. Power must be cycled to clear error	Error Suppressed due to low current draw
062 SHORTED CIRCUIT ENGINE THROTTLE	Excessive load was detected when Engine Throttle circuit was energized	Use a piece of wire to short the Engine Throttle coil	This is a latched error. Power must be cycled to clear error	Error Suppressed due to low current draw
063 OPEN CIRCUIT ENGINE STARTER	A load of less than 70mA was detected when Engine Starter circuit was energized	Disconnect a wire from Engine Starter coil	This is a latched error. Power must be cycled to clear error	Not Tested, Do not want to crank engine on power up
064 SHORTED CIRCUIT ENGINE STARTER	Excessive load was detected when Engine Starter circuit was energized	Use a piece of wire to short the Engine Starter coil	This is a latched error. Power must be cycled to clear error	Not Tested, Do not want to crank engine on power up
065 OPEN CIRCUIT ENGINE CHOKE	A load of less than 70mA was detected when Engine Choke circuit was energized	Disconnect a wire from Engine Choke coil	This is a latched error. Power must be cycled to clear error	Error Suppressed due to low current draw
066 SHORTED CIRCUIT ENGINE CHOKE	Excessive load was detected when Engine Choke circuit was energized	Use a piece of wire to short the Engine Choke coil	This is a latched error. Power must be cycled to clear error	Error Suppressed due to low current draw
067 OPEN CIRCUIT ENGINE STOP	A load of less than 70mA was detected when Engine Stop circuit was energized	Disconnect a wire from Engine Stop coil	This is a latched error. Power must be cycled to clear error	Error Suppressed due to low current draw
068 SHORTED CIRCUIT ENGINE STOP	Excessive load was detected when Engine Stop circuit was energized	Use a piece of wire to short the Engine Stop coil	This is a latched error. Power must be cycled to clear error	Error Suppressed due to low current draw
069 OPEN CIRCUIT PROPORTION-AL	A load of less than 70mA was detected when Proportional circuit was energized	Disconnect a wire from Proportional coil	This is a latched error. Power must be cycled to clear error	Checked only at power up
070 SHORTED CIRCUIT PROPORTIONAL	Excessive load was detected when Proportional circuit was energized	Use a piece of wire to short the Proportional coil	This is a latched error. Power must be cycled to clear error	Checked only at power up
071 OPEN CIRCUIT MOTOR CONTROL ENABLE	A load of less than 70mA was detected when Motor Control Enable circuit was energized	Disconnect a wire from Motor Control Enable coil		Error Suppressed due to low current draw
072 SHORTED CIRCUIT MOTOR CONTROL ENABLE	Excessive load was detected when Motor Control Enable circuit was energized	Use a piece of wire to short the Motor Control Enable coil		Error Suppressed due to low current draw

TABLE 4-3. ERROR CODE DEFINITIONS

ERROR MESSAGE	ERROR DEFINITION	TO SIMULATE ERROR	TO CLEAR ERROR	COMMENTS
073 OPEN CIRCUIT SPARE OUTPUT	A load of less than 70mA was detected when Spare Output circuit was energized	Disconnect a wire from Spare Output coil	This is a latched error. Power must be cycled to clear error	Not Used
074 SHORTED CIRCUIT SPARE OUTPUT	Excessive load was detected when Spare Output circuit was energized	Use a piece of wire to short the Spare Output coil	This is a latched error. Power must be cycled to clear error	Not Used
075 OPEN CIRCUIT AC SWITCH	A load of less than 70mA was detected when AC Switch circuit was energized	Disconnect a wire from AC Switch coil		Error Suppressed due to low current draw
076 SHORTED CIRCUIT AC SWITCH	Excessive load was detected when AC Switch circuit was energized	Use a piece of wire to short the AC Switch coil		Error Suppressed due to low current draw
077 OPEN CIRCUIT STROBE	A load of less than 70mA was detected when Strobe circuit was energized	Disconnect a wire from Strobe		Error Suppressed due to low current draw
078 SHORTED CIRCUIT STROBE	Excessive load was detected when Strobe circuit was energized	Use a piece of wire to short the Strobe coil		Error Suppressed due to low current draw
079 OPEN CIRCUIT DRIVE PWM	A load of less than 70mA was detected when Drive PWM circuit was energized	Disconnect a wire from Drive PWM coil	This is a latched error. Power must be cycled to clear error	Checked only at power up Machines with Drive option only
080 SHORTED CIRCUIT DRIVE PWM	Excessive load was detected when Drive PWM circuit was energized	Use a piece of wire to short the Drive PWM coil	This is a latched error. Power must be cycled to clear error	Checked only at power up Machines with Drive option only
081 OPEN CIRCUIT DRIVE ENABLE	A load of less than 70mA was detected when Drive Enable circuit was energized	Disconnect a wire from Drive Enable coil	This is a latched error. Power must be cycled to clear error	Checked only at power up Machines with Drive option only
082 SHORTED CIRCUIT DRIVE ENABLE	Excessive load was detected when Drive Enable circuit was energized	Use a piece of wire to short the Drive Enable coil	This is a latched error. Power must be cycled to clear error	Checked only at power up Machines with Drive option only
083 OPEN CIRCUIT DRIVE DUMP (C21)	A load of less than 70mA was detected when Drive Dump (C21) circuit was energized	Disconnect a wire from Drive Dump (C21) coil	This is a latched error. Power must be cycled to clear error	Checked only at power up Machines with 4WD option only
084 SHORTED CIRCUIT DRIVE DUMP (C21)	Excessive load was detected when Drive Dump (C21) circuit was energized	Use a piece of wire to short the Drive Engage coil	This is a latched error. Power must be cycled to clear error	Checked only at power up Machines with 4WD option only
085 OPEN CIRCUIT TURN LEFT (C22)	A load of less than 70mA was detected when Turn Left (C22) circuit was energized	Disconnect a wire from Turn Left (C22) coil	This is a latched error. Power must be cycled to clear error	Checked only at power up Machines with 4WD option only
086 SHORTED CIRCUIT TURN LEFT (C22)	Excessive load was detected when Turn Left (C22) circuit was energized	Use a piece of wire to short the Turn Left (C22) coil	This is a latched error. Power must be cycled to clear error	Checked only at power up Machines with 4WD option only
087 OPEN CIRCUIT TURN RIGHT (C23)	A load of less than 70mA was detected when Turn Right (C23) circuit was energized	Disconnect a wire from Turn Right (C23) coil	This is a latched error. Power must be cycled to clear error	Checked only at power up Machines with 4WD option only

TABLE 4-3. ERROR CODE DEFINITIONS

ERROR MESSAGE	ERROR DEFINITION	TO SIMULATE ERROR	TO CLEAR ERROR	COMMENTS
088 SHORTED CIRCUIT TURN RIGHT (C23)	Excessive load was detected when Turn Right (C23) circuit was energized	Use a piece of wire to short the Turn Right (C23) coil	This is a latched error. Power must be cycled to clear error	Checked only at power up Machines with 4WD option only
089 OPEN CIRCUIT FORWARD 1 (C24)	A load of less than 70mA was detected when Forward 1 (C24) circuit was energized	Disconnect a wire from Forward 1 (C24) coil	This is a latched error. Power must be cycled to clear error	Checked only at power up Machines with 4WD option only
090 SHORTED CIRCUIT FORWARD 1 (C24)	Excessive load was detected when Forward 1 (C24) circuit was energized	Use a piece of wire to short the Forward 1 (C24) coil	This is a latched error. Power must be cycled to clear error	Checked only at power up Machines with 4WD option only
091 OPEN CIRCUIT REVERSE 1 (C25)	A load of less than 70mA was detected when Reverse 1 (C25) circuit was energized	Disconnect a wire from Reverse 1 (C25) coil	This is a latched error. Power must be cycled to clear error	Checked only at power up Machines with 4WD option only
092 SHORTED CIRCUIT REVERSE 1 (C25)	Excessive load was detected when Reverse 1 (C25) circuit was energized	Use a piece of wire to short the Reverse 1 (C25) coil	This is a latched error. Power must be cycled to clear error	Checked only at power up Machines with 4WD option only
093 OPEN CIRCUIT FORWARD 2 (C27)	A load of less than 70mA was detected when Forward 2 (C27) circuit was energized	Disconnect a wire from Forward 2 (C27) coil	This is a latched error. Power must be cycled to clear error	Checked only at power up Machines with 4WD option only
094 SHORTED CIRCUIT FORWARD 2 (C27)	Excessive load was detected when Forward 2 (C27) circuit was energized	Use a piece of wire to short the Forward 2 (C27) coil	This is a latched error. Power must be cycled to clear error	Checked only at power up Machines with 4WD option only
095 OPEN CIRCUIT REVERSE 2 (C28)	A load of less than 70mA was detected when Reverse 2 (C28) circuit was energized	Disconnect a wire from Reverse 2 (C28) coil	This is a latched error. Power must be cycled to clear error	Checked only at power up Machines with 4WD option only
096 SHORTED CIRCUIT REVERSE 2 (C28)	Excessive load was detected when Reverse 2 (C28) circuit was energized	Use a piece of wire to short the Reverse 2 (C28) coil	This is a latched error. Power must be cycled to clear error	Checked only at power up Machines with 4WD option only
097 OPEN CIRCUIT TORQUE H/L (C29)	A load of less than 70mA was detected when Torque H/L (C29) circuit was energized	Disconnect a wire from Torque H/L (C29) coil	This is a latched error. Power must be cycled to clear error	Checked only at power up Machines with 4WD option only
098 SHORTED CIRCUIT TORQUE H/L (C29)	Excessive load was detected when Torque H/L (C29) circuit was energized	Use a piece of wire to short the Torque H/L (C29) coil	This is a latched error. Power must be cycled to clear error	Checked only at power up Machines with 4WD option only
099 OPEN CIRCUIT TORQUE H/L (C30)	A load of less than 70mA was detected when Torque H/L (C30) circuit was energized	Disconnect a wire from Torque H/L (C30) coil	This is a latched error. Power must be cycled to clear error	Checked only at power up Machines with 4WD option only
100 SHORTED CIRCUIT TORQUE H/L (C30)	Excessive load was detected when Torque H/L (C30) circuit was energized	Use a piece of wire to short the Torque H/L (C30) coil	This is a latched error. Power must be cycled to clear error	Checked only at power up Machines with 4WD option only
101 OPEN CIRCUIT TORQUE H/L (C31)	A load of less than 70mA was detected when Torque H/L (C31) circuit was energized	Disconnect a wire from Torque H/L (C31) coil	This is a latched error. Power must be cycled to clear error	Checked only at power up Machines with 4WD option only
102 SHORTED CIRCUIT TORQUE H/L (C31)	Excessive load was detected when Torque H/L (C31) circuit was energized	Use a piece of wire to short the Torque H/L (C31) coil	This is a latched error. Power must be cycled to clear error	Checked only at power up Machines with 4WD option only

TABLE 4-3. ERROR CODE DEFINITIONS

ERROR MESSAGE	ERROR DEFINITION	TO SIMULATE ERROR	TO CLEAR ERROR	COMMENTS
103 OUTREACH NEAR MAXIMUM	Boom has exceeded 95% of maximum outreach	Put 500lbs in boom, level boom and extend until alarm sounds and error is displayed	This is a self clearing error. When error condition is corrected, error is cleared	Machines with Moment Sense option only
104 OUTREACH AT MAXIMUM	Boom has reached maximum outreach setting	Put 500lbs in boom, level boom and extend until alarm sounds and error is displayed	This is a self clearing error. When error condition is corrected, error is cleared	Machines with Moment Sense option only
105 OVER MAXIMUM CYLINDER PRESSURE	Cylinder pressure has exceeded maximum pressure setting	Put 500lbs in boom, lower cylinder pressure setting using configuration program and extend boom until alarm sounds and error is displayed	This is a latched error. Power must be cycled to clear error	Machines with Moment Sense option only
106 OUTREACH SENSING FAULT	Cylinder safety pressure switch has detected maximum pressure setting	Disconnect safety pressure switch wires	This is a latched error. Power must be cycled to clear error	Machines with Moment Sense option only
107 ENGINE TEMP HIGH CHECK WATER LEVEL	Excessive engine temperature was detected	Remove wire from engine temperature sensor and connect wire to ground	This is a self clearing error. When error condition is corrected, error is cleared	Machines with 4WS option only
108 CHECK ALTERNATOR NOT CHARGING	Engine alternator is not charging	Remove P wire from alternator and connect wire to ground	This is a self clearing error. When error condition is corrected, error is cleared	Machines with 4WS option only
109 ENGINE RPM FAULT HIGH RPM IS TOO LOW	When driving, engine high RPM was too low	Misadjust engine high RPM to a value less than 3000 RPM and attempt to drive	This is a latched error. Power or engine must be cycled to clear error	Machines with 4WS option only
121 OPEN CIRCUIT BRAKE (FWS C21)	A load of less than 70mA was detected when Brake (FWS C21) circuit was energized	Disconnect a wire from Brake (FWS C21) coil	This is a latched error. Power must be cycled to clear error	Checked only at power up Machines with 4WS option only
122 SHORTED CIRCUIT BRAKE (FWS C21)	Excessive load was detected when Brake (FWS C21) circuit was energized	Use a piece of wire to short the Brake (FWS C21) coil	This is a latched error. Power must be cycled to clear error	Checked only at power up Machines with 4WS option only
123 OPEN CIRCUIT RS RET (FWS C22)	A load of less than 70mA was detected when RS Ret (FWS C22) circuit was energized	Disconnect a wire from RS Ret (FWS C22) coil	This is a latched error. Power must be cycled to clear error	Checked only at power up Machines with 4WS option only
124 SHORTED CIRCUIT RS RET (FWS C22)	Excessive load was detected when RS Ret (FWS C22) circuit was energized	Use a piece of wire to short the RS Ret (FWS C22) coil	This is a latched error. Power must be cycled to clear error	Checked only at power up Machines with 4WS option only
125 OPEN CIRCUIT RS EXT (FWS C23)	A load of less than 70mA was detected when RS Ext (FWS C23) circuit was energized	Disconnect a wire from RS Ext (FWS C23) coil	This is a latched error. Power must be cycled to clear error	Checked only at power up Machines with 4WS option only
126 SHORTED CIRCUIT RS EXT (FWS C23)	Excessive load was detected when RS Ext (FWS C23) circuit was energized	Use a piece of wire to short the RS Ext (FWS C23) coil	This is a latched error. Power must be cycled to clear error	Checked only at power up Machines with 4WS option only
127 OPEN CIRCUIT FS RET (FWS C24)	A load of less than 70mA was detected when FS Ret (FWS C24) circuit was energized	Disconnect a wire from FS Ret (FWS C24) coil	This is a latched error. Power must be cycled to clear error	Checked only at power up Machines with 4WS option only

TABLE 4-3. ERROR CODE DEFINITIONS

ERROR MESSAGE	ERROR DEFINITION	TO SIMULATE ERROR	TO CLEAR ERROR	COMMENTS
128 SHORTED CIRCUIT FS RET (FWS C24)	Excessive load was detected when FS Ret (FWS C24) circuit was energized	Use a piece of wire to short the FS Ret (FWS C24) coil	This is a latched error. Power must be cycled to clear error	Checked only at power up Machines with 4WS option only
129 OPEN CIRCUIT FS EXT (FWS C25)	A load of less than 70mA was detected when FS Ext (FWS C25) circuit was energized	Disconnect a wire from FS Ext (FWS C25) coil	This is a latched error. Power must be cycled to clear error	Checked only at power up Machines with 4WS option only
130 SHORTED CIRCUIT FS RET (FWS C25)	Excessive load was detected when FS Ext (FWS C25) circuit was energized	Use a piece of wire to short the FS Ext (FWS C25) coil	This is a latched error. Power must be cycled to clear error	Checked only at power up Machines with 4WS option only
131 OPEN CIRCUIT DC D FWD (FWS C26)	A load of less than 70mA was detected when DC D Fwd (FWS C26) circuit was energized	Disconnect a wire from DC D Fwd (FWS C26) coil	This is a latched error. Power must be cycled to clear error	Checked only at power up Machines with 4WS option only
132 SHORTED CIRCUIT DC D FWD (FWS C26)	Excessive load was detected when DC D Fwd (FWS C26) circuit was energized	Use a piece of wire to short the DC D Fwd (FWS C26) coil	This is a latched error. Power must be cycled to clear error	Checked only at power up Machines with 4WS option only
133 OPEN CIRCUIT DC D REV (FWS C27)	A load of less than 70mA was detected when DC D Rev (FWS C27) circuit was energized	Disconnect a wire from DC D Rev (FWS C27) coil	This is a latched error. Power must be cycled to clear error	Checked only at power up Machines with 4WS option only
134 SHORTED CIRCUIT DC D REV (FWS C27)	Excessive load was detected when DC D Rev (FWS C27) circuit was energized	Use a piece of wire to short the DC D Rev (FWS C27) coil	This is a latched error. Power must be cycled to clear error	Checked only at power up Machines with 4WS option only
135 OPEN CIRCUIT DC D (FWS C28)	A load of less than 70mA was detected when DC D (FWS C28) circuit was energized	Disconnect a wire from DC D (FWS C28) coil	This is a latched error. Power must be cycled to clear error	Checked only at power up Machines with 4WS option only
136 SHORTED CIRCUIT DC D (FWS C28)	Excessive load was detected when DC D (FWS C28) circuit was energized	Use a piece of wire to short the DC D (FWS C28) coil	This is a latched error. Power must be cycled to clear error	Checked only at power up Machines with 4WS option only
137 OPEN CIRCUIT DC D (FWS C29)	A load of less than 70mA was detected when DC D (FWS C29) circuit was energized	Disconnect a wire from DC D (FWS C29) coil	This is a latched error. Power must be cycled to clear error	Checked only at power up Machines with 4WS option only
138 SHORTED CIRCUIT DC D (FWS C29)	Excessive load was detected when DC D (FWS C29) circuit was energized	Use a piece of wire to short the DC D (FWS C29) coil	This is a latched error. Power must be cycled to clear error	Checked only at power up Machines with 4WS option only
139 OPEN CIRCUIT DC D (FWS C30)	A load of less than 70mA was detected when DC D (FWS C30) circuit was energized	Disconnect a wire from DC D (FWS C30) coil	This is a latched error. Power must be cycled to clear error	Checked only at power up Machines with 4WS option only
140 SHORTED CIRCUIT DC D (FWS C30)	Excessive load was detected when DC D (FWS C30) circuit was energized	Use a piece of wire to short the DC D (FWS C30) coil	This is a latched error. Power must be cycled to clear error	Checked only at power up Machines with 4WS option only
141 OPEN CIRCUIT DC D (FWS C31)	A load of less than 70mA was detected when DC D (FWS C31) circuit was energized	Disconnect a wire from DC D (FWS C31) coil	This is a latched error. Power must be cycled to clear error	Checked only at power up Machines with 4WS option only
142 SHORTED CIRCUIT DC D (FWS C31)	Excessive load was detected when DC D (FWS C31) circuit was energized	Use a piece of wire to short the DC D (FWS C31) coil	This is a latched error. Power must be cycled to clear error	Checked only at power up Machines with 4WS option only

TABLE 4-3. ERROR CODE DEFINITIONS

ERROR MESSAGE	ERROR DEFINITION	TO SIMULATE ERROR	TO CLEAR ERROR	COMMENTS
143 OPEN CIRCUIT (FWS C32)	A load of less than 70mA was detected when (FWS C32) circuit was energized	Disconnect a wire from (FWS C32) coil	This is a latched error. Power must be cycled to clear error	Checked only at power up Machines with 4WS option only
144 SHORTED CIRCUIT (FWS C32)	Excessive load was detected when (FWS C32) circuit was energized	Use a piece of wire to short the (FWS C32) coil	This is a latched error. Power must be cycled to clear error	Checked only at power up Machines with 4WS option only
145 OPEN CIRCUIT (FWS C33)	A load of less than 70mA was detected when (FWS C33) circuit was energized	Disconnect a wire from (FWS C33) coil	This is a latched error. Power must be cycled to clear error	Checked only at power up Machines with 4WS option only
146 SHORTED CIRCUIT (FWS C33)	Excessive load was detected when (FWS C33) circuit was energized	Use a piece of wire to short the (FWS C33) coil	This is a latched error. Power must be cycled to clear error	Checked only at power up Machines with 4WS option only
147 OPEN CIRCUIT (FWS C34)	A load of less than 70mA was detected when (FWS C34) circuit was energized	Disconnect a wire from (FWS C34) coil	This is a latched error. Power must be cycled to clear error	Checked only at power up Machines with 4WS option only
148 SHORTED CIRCUIT (FWS C34)	Excessive load was detected when (FWS C34) circuit was energized	Use a piece of wire to short the (FWS C34) coil	This is a latched error. Power must be cycled to clear error	Checked only at power up Machines with 4WS option only
149 OPEN CIRCUIT (FWS R2)	A load of less than 70mA was detected when (FWS R2) circuit was energized	Disconnect a wire from (FWS R2) coil	This is a latched error. Power must be cycled to clear error	Checked only at power up Machines with 4WS option only
150 SHORTED CIRCUIT (FWS R2)	Excessive load was detected when (FWS R2) circuit was energized	Use a piece of wire to short the (FWS R2) coil	This is a latched error. Power must be cycled to clear error	Checked only at power up Machines with 4WS option only
151 OPEN CIRCUIT (FWS GEN G1)	A load of less than 70mA was detected when (FWS Gen G1) circuit was energized	Disconnect a wire from (FWS Gen G1) coil	This is a latched error. Power must be cycled to clear error	Checked only at power up Machines with 4WS option only
152 SHORTED CIRCUIT (FWS GEN G1)	Excessive load was detected when (FWS Gen G1) circuit was energized	Use a piece of wire to short the (FWS Gen G1) coil	This is a latched error. Power must be cycled to clear error	Checked only at power up Machines with 4WS option only
153 OPEN CIRCUIT (FWS CON 24V)	A load of less than 70mA was detected when (FWS Con 24V) circuit was energized	Disconnect a wire from (FWS Con 24V) coil	This is a latched error. Power must be cycled to clear error	Checked only at power up Machines with 4WS option only
154 SHORTED CIRCUIT (FWS CON 24V)	Excessive load was detected when (FWS Con 24V) circuit was energized	Use a piece of wire to short the (FWS Con 24V) coil	This is a latched error. Power must be cycled to clear error	Checked only at power up Machines with 4WS option only
155 OPEN CIRCUIT (FWS SPARE 1)	A load of less than 70mA was detected when (FWS Spare 1) circuit was energized	Disconnect a wire from (FWS Spare 1) coil	This is a latched error. Power must be cycled to clear error	Checked only at power up Machines with 4WS option only
156 SHORTED CIRCUIT (FWS SPARE 1)	Excessive load was detected when (FWS Spare 1) circuit was energized	Use a piece of wire to short the (FWS Spare 1) coil	This is a latched error. Power must be cycled to clear error	Checked only at power up Machines with 4WS option only
157 OPEN CIRCUIT (FWS SPARE 2)	A load of less than 70mA was detected when (FWS Spare 2) circuit was energized	Disconnect a wire from (FWS Spare 2) coil	This is a latched error. Power must be cycled to clear error	Checked only at power up Machines with 4WS option only

TABLE 4-3. ERROR CODE DEFINITIONS

ERROR MESSAGE	ERROR DEFINITION	TO SIMULATE ERROR	TO CLEAR ERROR	COMMENTS
158 SHORTED CIRCUIT (FWS SPARE 2)	Excessive load was detected when (FWS Spare 2) circuit was energized	Use a piece of wire to short the (FWS Spare 2) coil	This is a latched error. Power must be cycled to clear error	Checked only at power up Machines with 4WS option only
159 OPEN CIRCUIT (FWS SPARE 3)	A load of less than 70mA was detected when (FWS Spare 3) circuit was energized	Disconnect a wire from (FWS Spare 3) coil	This is a latched error. Power must be cycled to clear error	Checked only at power up Machines with 4WS option only
160 SHORTED CIRCUIT (FWS SPARE 3)	Excessive load was detected when (FWS Spare 3) circuit was energized	Use a piece of wire to short the (FWS Spare 3) coil	This is a latched error. Power must be cycled to clear error	Checked only at power up Machines with 4WS option only
161 OPEN CIRCUIT (FWS PROP A1)	A load of less than 70mA was detected when (FWS Prop A1) circuit was energized	Disconnect a wire from (FWS Prop A1) coil	This is a latched error. Power must be cycled to clear error	Checked only at power up Machines with 4WS option only
162 SHORTED CIRCUIT (FWS PROP A1)	Excessive load was detected when (FWS Prop A1) circuit was energized	Use a piece of wire to short the (FWS Prop A1) coil	This is a latched error. Power must be cycled to clear error	Checked only at power up Machines with 4WS option only
163 OPEN CIRCUIT (FWS PROP A2)	A load of less than 70mA was detected when (FWS Prop A2) circuit was energized	Disconnect a wire from (FWS Prop A2) coil	This is a latched error. Power must be cycled to clear error	Checked only at power up Machines with 4WS option only
164 SHORTED CIRCUIT (FWS PROP A2)	Excessive load was detected when (FWS Prop A2) circuit was energized	Use a piece of wire to short the (FWS Prop A2) coil	This is a latched error. Power must be cycled to clear error	Checked only at power up Machines with 4WS option only
165 OPEN CIRCUIT (FWS PROP B1)	A load of less than 70mA was detected when (FWS Prop B1) circuit was energized	Disconnect a wire from (FWS Prop B1) coil	This is a latched error. Power must be cycled to clear error	Checked only at power up Machines with 4WS option only
166 SHORTED CIRCUIT (FWS PROP B1)	Excessive load was detected when (FWS Prop B1) circuit was energized	Use a piece of wire to short the (FWS Prop B1) coil	This is a latched error. Power must be cycled to clear error	Checked only at power up Machines with 4WS option only
167 OPEN CIRCUIT (FWS PROP B2)	A load of less than 70mA was detected when (FWS Prop B2) circuit was energized	Disconnect a wire from (FWS Prop B2) coil	This is a latched error. Power must be cycled to clear error	Checked only at power up Machines with 4WS option only
168 SHORTED CIRCUIT (FWS PROP B2)	Excessive load was detected when (FWS Prop B2) circuit was energized	Use a piece of wire to short the (FWS Prop B2) coil	This is a latched error. Power must be cycled to clear error	Checked only at power up Machines with 4WS option only

ERROR CODE DEFINITIONS – MOTOR CONTROLLER

The Motor Controller indicates the operational status of the controller, it is located under the power compartment cover (left / drivers side), and behind the ground (lower) control panel. If an error condition is detected, the appropriate error code will be displayed by a flashing indicator light.

Refer to Figure 4-15 at the end of the error codes for a visual of the controller. Refer to Table 4-4 to resolve the Fault, or contact Haulotte Group Customer Service Department: at 1-800-537-0540 or visit Haulotte Group online at www.haulotte-usa.com with any questions.



INDICATOR LIGHT

Figure 4-15. Motor Controller

TABLE 4-4. ERROR CODE DEFINITIONS - MOTOR CONTROLLER

FLASH FAULT	PRIORITY ID	FAULT	DESCRIPTION	SOLUTION
Steady ON, no flashing	1	None	System is operating normally.	None required.
1	11	Configuration Range Error	One or more controller personality settings are out of range.	Use Sevcon calibrator to enter correct settings from latest Personality Sheet.
1	12	CRC Error	The controller personality checksum is incorrect.	Use Sevcon calibrator to enter correct settings from latest Personality Sheet. Otherwise, replace motor controller.
2	5	Sequence Fault	Enable line is active at power up.	Check enable line, B- wiring, and Molex connector.
2	6	Accelerator Fault	Invalid accelerator personality setting.	Check speed input line, B- wiring, Molex connector, and 1000 ohm resistor.
3	17	MOSFET Short Circuit	MOSFET short circuit or controller miswire detected	Check for miswired B+, B-, or pump cables. Make sure pump terminals are not shorted to frame. If cables and pump are OK, then replace motor controller.
4	14	Line Contactor Welded	The line contactor is welded or otherwise shorted.	Check line contactor wiring. If wiring is OK, then replace line contactor.
4	15	Line Contactor did not Close	Line contactor did not close or is otherwise open circuit.	Check line contactor wiring and Molex connector. Measure the contactor coil resistance; it should be around 50 ohms. If contactor and wiring are OK, then replace motor controller.

TABLE 4-4. ERROR CODE DEFINITIONS - MOTOR CONTROLLER

FLASH FAULT	PRIORITY ID	FAULT	DESCRIPTION	SOLUTION
5	16	Motor Open Circuit	Pump motor cable disconnected.	Check pump-motor and controller cables. Measure pump motor resistance it should be near zero ohms.
6	N/A	Not used in this application	N/A	N/A
7	7	Low Battery	Battery voltage is too low.	Recharge the batteries. Look for shorted battery cells. Make sure one or more batteries are not reversed.
7	8	High Battery	Battery voltage is too high.	Make sure battery charger is off. Check for poor or corroded battery connections.
7	10	High Battery with Line Contactor Open	High battery voltage was detected at power up before line contactor closed.	Make sure battery charger is off or that the battery is not overcharged.
8	1	Thermal Cutback	Maximum power available to motor has been reduced due to excessive heat sink temperature.	Remove power and allow controller to cool. If fault repeatedly occurs, look for binding on the hydraulic cylinders or sticking valves. Otherwise, the pump motor may be failing.
8	3	Pump I ² T Current Limit Cutback	Maximum power available to pump motor has been reduced by the Current Limit Cutback function.	Recycle power. If fault repeatedly occurs, look for binding on the hydraulic cylinders or sticking valves. Otherwise, the pump motor may be failing.
9	N/A	Not used in this application	N/A	N/A
10	N/A	Not used in this application	N/A	N/A
11	18	Auto Zero Out of Range	Internal pump current measurement circuit could not be calibrated.	Replace motor controller.
11	24	System Monitor	Illegal system condition sensed due to internal hardware fault.	Replace motor controller.
Single flash, then off	19	MOSFETs Off	MOSFETs did not pulse when the internal failsafe circuit was enabled.	Check for reversed cables among B+, B-, and A terminals. If no miswire is found, replace motor controller.
Single flash, then off	20	MOSFETs On	MOSFETs pulsed while the internal failsafe circuit was disabled.	Check for reversed cables among B+, B-, and A terminals. If no miswire is found, replace motor controller.
Single flash, then off	22	Contactors Drive Off	Contactors output did not pulse with the internal failsafe circuit enabled.	Replace motor controller.
Single flash, then off	23	Contactors Drive On	Contactors output pulsed while the internal failsafe circuit was disabled.	Replace motor controller.

5 CYLINDER REPLACEMENT

If repair or replacement of an aerial work platform or outrigger hydraulic cylinder(s) or its component parts becomes necessary, observe the following procedures in accordance with the safety precautions established in the “Safety” section of this manual.

Removal of hydraulic cylinders from the aerial work platform may require the use of specialized tools and lifting equipment. **NEVER** attempt to operate overhead hoists or cranes or related equipment without proper training, authorization and supervision. Perform all maintenance procedures only in an area that is well-lit and well-ventilated. Haulotte Group is not responsible for personal injury or property damage resulting from the improper use of equipment or failure to follow all procedures and related safety precautions.

Direct all questions regarding cylinder removal and replacement to Haulotte Group Customer Service Department: at 1-800-537-0540 or visit Haulotte Group online at www.haulotte-usa.com.

WARNING

Repair and removal of the hydraulic cylinder requires the use of lifting straps and an overhead crane or lifting gear to support the aerial work platform and hydraulic cylinders. Personnel should be thoroughly trained in the operation of these devices before attempting installation or removal. Hydraulic cylinders are heavy and may have hydraulic oil on their surface. Failure to use proper equipment or to securely support aerial work platform and cylinders could result in death or serious injury and damage to aerial work platform.

MASTER / SLAVE CYLINDER REPLACEMENT

Use the following procedure to remove and replace faulty cylinders.

Master Cylinder

Refer to Figure 5–1 for the location of this cylinder.

- With the boom in the “stowed” position, raise the upper boom until there is adequate exposure of the pin retainer and pivot pin.
- Verify that the upper boom is supported by lifting straps and an overhead hoist or equivalent.
- Unbolt and remove the pin retainer at the rod end of the cylinder.
- Remove the pivot pin using a hammer and a brass or hardwood drift.
- Tag and number all hydraulic hoses that attach to the cylinder valve block. Use a marker to label the valve block ports with the appropriate hose numbers.

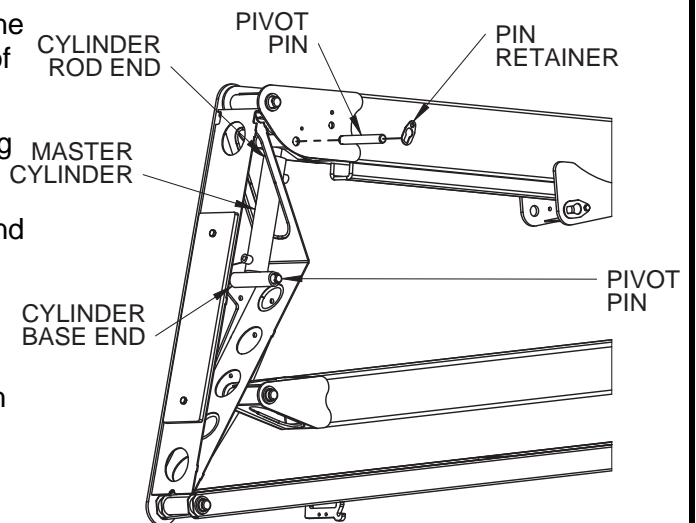

Figure 5-1. Location of Master Cylinder

MASTER / SLAVE CYLINDER REPLACEMENT (CONTINUED)

Master Cylinder (Continued)

- Place absorbent cloths below the cylinder ports and detach hydraulic hoses from the cylinder. Elevate hoses to prevent leakage. Plug or cap exposed hose fittings and cylinder ports.
- Unbolt and remove the pin retainer at the base end of the cylinder.
- Remove the pivot pin using a hammer and a brass or hardwood drift.
- Replace or reinstall the cylinder by following the above instructions in the reverse order of removal.
- Actuate the hydraulic system and check for leakage. Tighten hydraulic fittings as needed.
- Bleed trapped air from the hydraulic system by raising and lowering the telescoping boom with the reservoir fill port cap on, but not tightened. Allow several cycles of operation for trapped air to escape. Repeat as necessary.

Slave Cylinder

Refer to Figure 5–2 for the location of this cylinder.

- With the boom in the “stowed” position, extend the telescoping boom until there is adequate exposure of the pin retainer and pivot pin (approximately 2 ft. (0.7 m)).
- Verify that the upper boom is supported by lifting straps and an overhead hoist or equivalent.
- Unbolt and remove the pin retainer at the rod end of the cylinder.
- Remove the pivot pin using a hammer and a brass or hardwood drift.
- Tag and number all hydraulic hoses that attach to the cylinder valve block. Use a marker to label the valve block ports with the appropriate hose numbers.
- Place absorbent cloths below the cylinder ports and detach hydraulic hoses from the cylinder. Elevate hoses to prevent leakage. Plug or cap exposed hose fittings and cylinder ports.
- Unbolt and remove both pin retainers at the base end of the cylinder.
- Remove the pivot pin using a hammer and a brass or hardwood drift.
- Replace or reinstall the cylinder by following the above instructions in the reverse order of removal.
- Actuate the hydraulic system and check for leakage. Tighten hydraulic fittings as needed.
- Bleed trapped air from the hydraulic system by raising and lowering the telescoping boom with the reservoir fill port cap on, but not tightened. Allow several cycles of operation for trapped air to escape. Repeat as necessary.

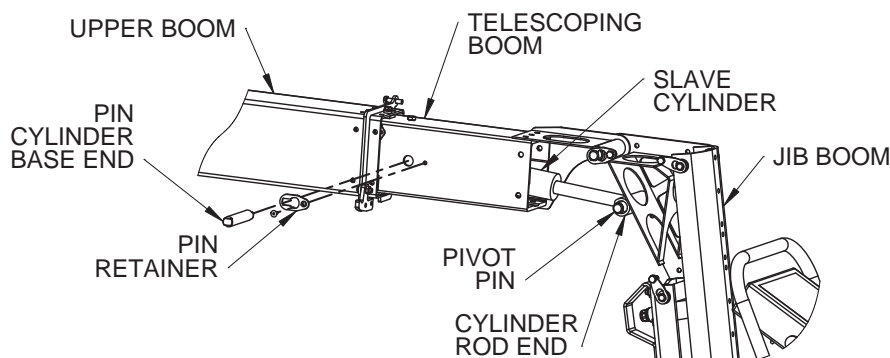

Figure 5-2. Location of Slave Cylinder

LIFT CYLINDER REPLACEMENT

4527A / HTA 16 P Aerial Work Platforms have three (3) lift cylinders, use the following procedure to remove and replace faulty or damaged hydraulic cylinders. Refer to Figure 5-3 for the location of these cylinders.

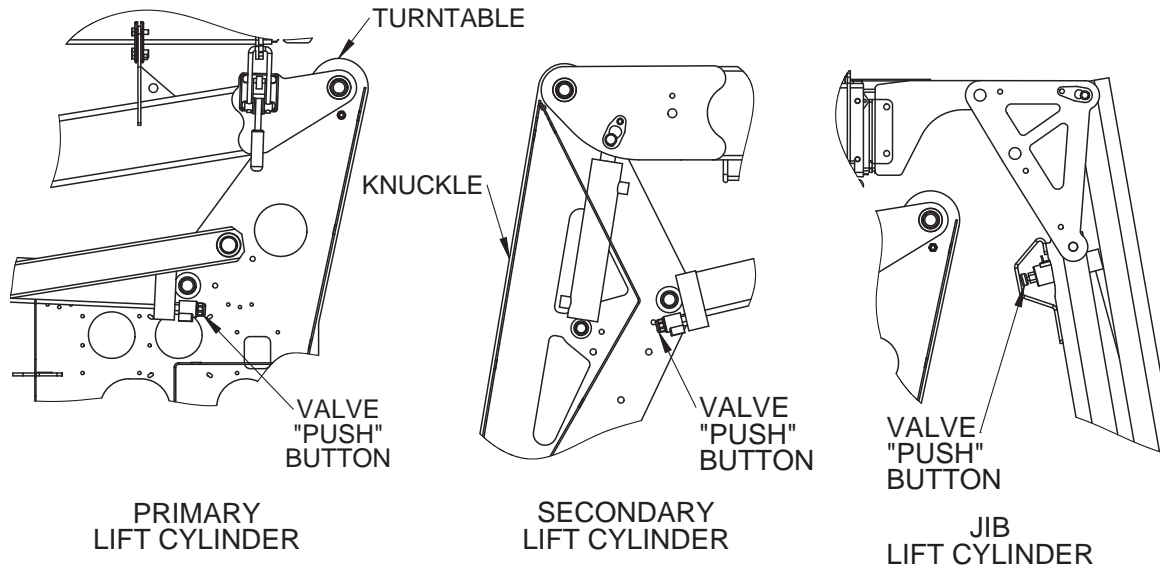

Figure 5-3. Location of Manual Lowering Valves

- Press (push) in and hold the emergency lowering valve “button” on the lift cylinder to relieve all hydraulic pressure to the cylinder. Refer to Figure 5-4.
- Turn the key switch at the ground (lower) control panel, to the “OFF” position and remove the key.
- Locate the piston rod end of the cylinder to be removed. Unbolt and remove the pin retainer from each side of the pivot pin. Refer to Figure 5-5.

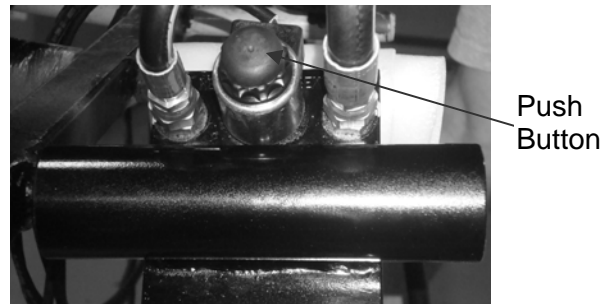

Figure 5-4. Push “Button” Lowering Valve

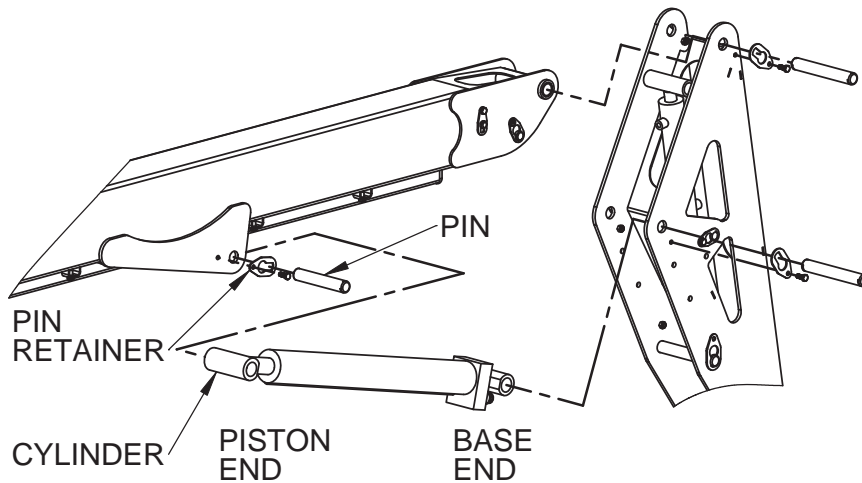

Figure 5-5. Lift Cylinder Replacement

LIFT CYLINDER REPLACEMENT (CONTINUED)

- Verify that the cylinder is supported by lifting straps and an overhead hoist or equivalent.
- Remove the pivot pin using a hammer and a brass or hardwood drift.
- Use an overhead crane or lifting gear to raise the boom section. Adequate clearance is necessary to reach the cylinder valve block (base end) and hydraulic hose ports.
- Remove the valve solenoid by unscrewing the cap, sliding the coil off, then unscrewing the valve.
- Place absorbent cloths below the cylinder ports and detach hydraulic hoses from the cylinder. Elevate hoses to prevent leakage. Plug or cap exposed hose fittings and cylinder ports.
- At the base of the cylinder, unbolt and remove the pin retainer from each side of the pivot pin.
- Remove the pivot pin using a hammer and a brass or hardwood drift.
- Lift and remove the cylinder using an overhead hoist and lifting straps or equivalent.
- Replace or reinstall the cylinder by following the above instructions in the reverse order of removal.
- Actuate the hydraulic system and check for leakage. Tighten hydraulic fittings as needed.
- Bleed trapped air from the hydraulic system by raising and lowering the boom with the reservoir fill port cap on, but not tightened. Allow several cycles of operation for trapped air to escape. Repeat as necessary.

OUTRIGGER CYLINDER REPLACEMENT

Use the following procedure to remove and replace faulty or damaged hydraulic cylinders on the outriggers:

- Lower the outrigger until the footpad is touching the ground. **DO NOT** transfer the weight of the aerial work platform onto the outrigger. Leave the weight of the aerial work platform on the trailer wheels.
- Remove the bolts securing the outrigger cylinder guard. Remove the cylinder guard. Refer to Figure 5-6.

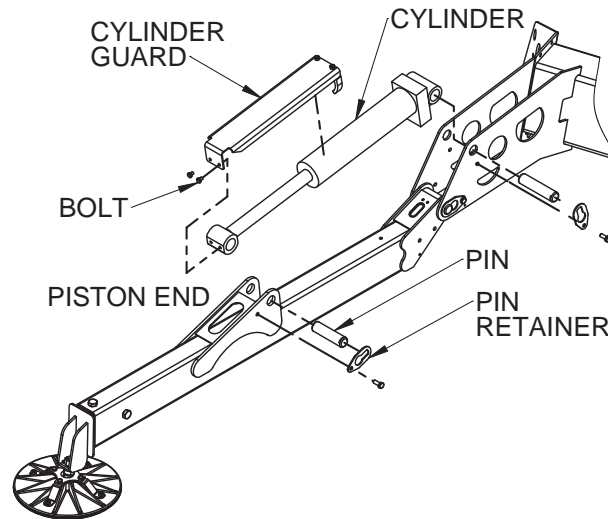

Figure 5-6. Outrigger Cylinder Replacement

- At the piston rod end of the cylinder, unbolt and remove the pin retainer from each side of the pivot pin.
- Place a block of wood shoring between the outrigger tube and the cylinder.
- Remove the pivot pin using a hammer and a brass or hardwood drift.
- Fully retract the cylinder.
- Turn the key at the ground (lower) control station to the "OFF" position and remove the key.
- Tag and number all hydraulic hoses that attach to the cylinder valve block. Use a marker to label the valve block ports with the appropriate hose numbers.
- Remove the valve solenoid by unscrewing the cap, sliding the coil off, then unscrewing the valve. Refer to Figure 5-7.
- Place absorbent cloths below the cylinder ports and detach hydraulic hoses from the cylinder. Elevate hoses to prevent leakage. Plug or cap exposed hose fittings and cylinder ports.



Figure 5-7. Cylinder Valve Removal

OUTRIGGER CYLINDER REPLACEMENT (CONTINUED)

- At the base of the cylinder, unbolt and remove the pin retainer from each side of the pivot pin.
- Remove the pivot pin using a hammer and a brass or hardwood drift.
- Lift and remove the cylinder using an overhead hoist and lifting straps or equivalent.
- Replace or reinstall the cylinder by following the above instructions in the reverse order of removal.
- Actuate the hydraulic system and check for leakage. Tighten hydraulic fittings as necessary.
- Bleed trapped air from the hydraulic system by extending and retracting the outrigger with the reservoir fill port cap on but not tightened. Allow several cycles of operation for trapped air to escape. Repeat as necessary.

6 DECAL REPLACEMENT



WARNING

Decals contain information that is required for the safe and proper use of the aerial work platform.

Decals should be considered necessary components of the machine and should be checked before each use to verify that they are correctly attached and legible.

Promptly replace all decals that are no longer legible.

DECAL KIT - ANSI

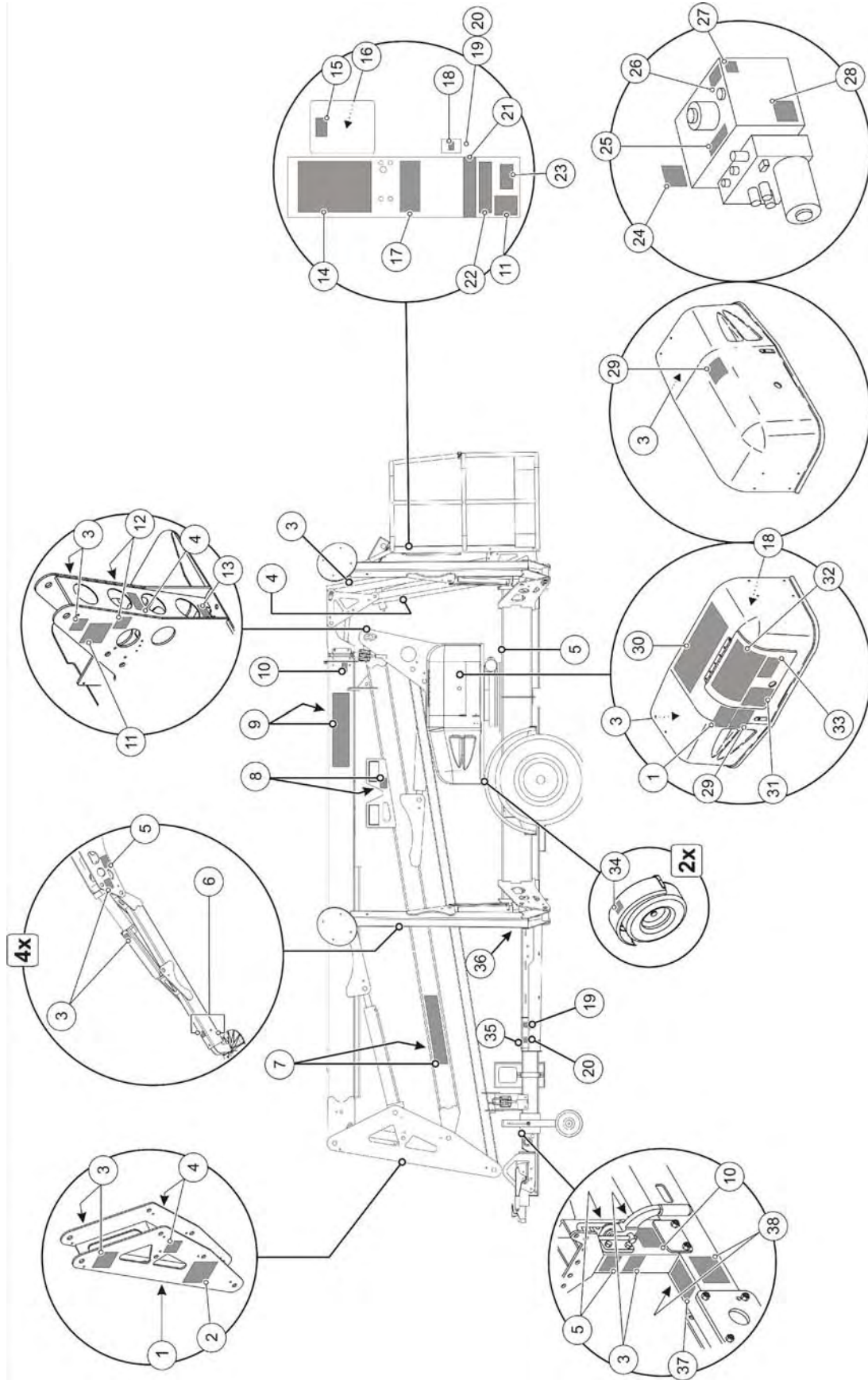

DECAL KIT – ANSI

B06-01-4012		DECAL KIT - Includes the following:	
ITEM NO.	PART NUMBER	DESCRIPTION	QTY.
1	B06-00-0550	Decal - Warning - Unhitch To Operate	2
2	B06-00-0551	Decal - Caution - Latch / Jack / Brake	1
3	B06-00-0405	Decal - Warning - Hand Pinch Point	17
4	B06-00-0403	Decal - Emergency Lower Valve	4
5	B06-00-0521	Decal - Danger - Tip Over Hazard	7
6	B06-00-0404	Decal - Warning - Outrigger Crush Foot	8
7	B06-00-0161B	Decal - 'Haulotte BilJax' - 5in Black / Red on Clear	2
8	B06-00-0477	Decal - Warning - Fork Lift Use	2
9	B06-00-0539	Decal - 4527A Transfer - Black	2
10	B06-00-0481	Decal - Caution - Transport Latch	2
11	B06-00-0536	Decal - Notice - Range of Motion - 4527A	2
12	B06-00-0482	Decal - Danger - Electrocution	2
13	B06-00-0037	Decal - "Lubricate Semi - Annually"	1
14	B06-00-0471	Decal - Danger - Main Instruction / Hazard - Platform	1
15	B06-00-0475	Decal - Warning - Read / Understand Manual	1
16	B06-00-0473	Decal - Notice - Operator Manual Missing	1
17	B06-00-0534	Decal - Warning - Platform Operation - Articulating	1
18	B06-00-0062	Decal - Notice - AC Power	2
19	B06-00-0530	Decal - Air - 120 PSI	2
20	B06-00-0531	Decal - Water - 3000 PSI	2
21	B06-00-0552	Decal - Notice - Lanyard Attachment	1
22	B06-00-0474	Decal - Notice - Platform Maximum Load	1
23	0202-0523	Decal - Flag, Made In USA	1
24	B06-00-0503	Decal - Notice - Handle Applications	1
25	B06-00-0504	Decal - Notice - Emergency Hand Pump	1
26	B06-00-0068	Decal - Notice - Low Foam Hydraulic Oil	1
27	B06-00-0494	Decal - Notice - Contains Hazardous Material	1
28	B06-00-0541	Decal - Caution - Manual Rotate / Retract	1
29	B06-00-0495	Decal - Caution - Compartment Access	2
30	B06-00-0505	Decal - Danger - Main Instruction / Hazard - Base	1
31	B06-00-0034	Decal - Danger - Battery / Charger Safety	1
32	B06-00-0533	Decal - Warning, Ground Operation Instructions - Articulating	2
33	B06-00-0484	Decal - Danger - Battery / Charger Instruction	1
34	B06-00-0543	Decal - Warning - Crush Hazard	2
35	B06-00-0496	Decal - Caution - Generator Plate Maximum 200	1
36	B06-00-0478	Decal - Notice - AC Power Connection	1
37	B06-00-0542	Decal - Warning - Maximum Tow Speed 65	1
38	B06-00-0544	Decal - Warning - Tow Hazard 65 mph	2

IDENTIFICATION PLATES & OPTIONAL EQUIPMENT - ANSI

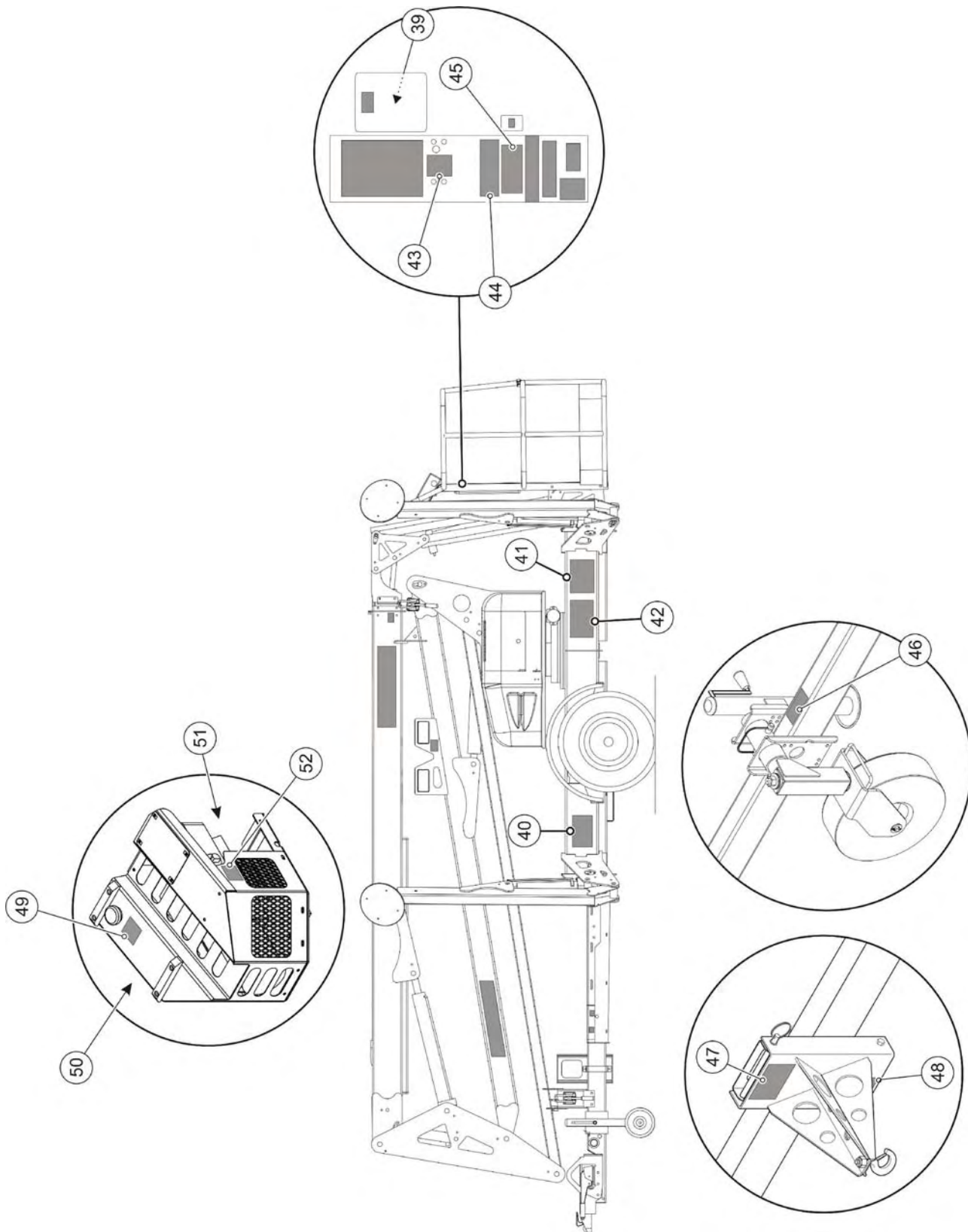

IDENTIFICATION PLATES & OPTIONAL EQUIPMENT - ANSI**IDENTIFICATION PLATES – ANSI (Used on all standard equipment)**

ITEM NO.	PART NUMBER	DESCRIPTION	QTY.
39	B06-00-0526	Key Ring Tag	1
40	B06-00-0524	Annual Inspection Plate	1
41	B06-00-0490	VIN Plate	1
42	B06-00-0499	ANSI ID Plate	1

DECALS FOR OPTIONAL EQUIPMENT – ANSI

ITEM NO.	PART NUMBER	DESCRIPTION	QTY.
43	B06-00-0529	Decal - Notice - Platform Rotate (Manual Rotation Option)	1
44	B06-00-0527	Decal - Warning - Drive and Set (Drive and Set Option)	1
45	B06-00-0528	Decal - Notice - Drive and Set (Drive and Set Option)	1
46	B06-00-0553	Decal - Warning - Jockey Wheel (Drive and Set Option)	1
47	B06-00-0485	Decal - Notice - Material Lift Set - up (Material Lift Option)	1
48	B06-00-0497	Decal - Notice - Material Lift Max 500 (Material Lift Option)	1
49	B06-00-0487	Decal - Notice - Unleaded Fuel Only (Gas Engine Option)	1
50	B06-00-0488	Decal - Caution - Component Damage (Gas Engine Option)	1
51	B06-00-0486	Decal - Notice - Engine Specific (Gas Engine Option)	1
52	B06-00-0547	Decal - Warning - Eng Operate - Hot (Gas Engine Option)	1

DECALS - ANSI

⚠ DANGER

FAILURE TO READ, UNDERSTAND AND FOLLOW THESE SAFETY INSTRUCTIONS OR ANY IMPROPER USE OF THIS EQUIPMENT WILL RESULT IN SERIOUS INJURY OR DEATH.

BEFORE USE
Operator is responsible for proper machine operation.

DO NOT operate this machine unless you have:

- been fully trained in proper operation.
- read and understood Operators Manual.
- read and understood all warning and instruction decals.

Inspect lift for any damaged or worn components (see Operators Manual for complete maintenance and inspection procedures)

NEVER TAKE CHANCES - DO NOT use this lift if you are under the influence of drugs or alcohol, or if you feel dizzy, ill or unsteady.

SET UP
Survey the jobsite and identify all potential hazards. Operator is responsible to avoid all hazardous situations. Cordon off area around base to keep unauthorized personnel and other equipment away from machine. Operate on firm and level surface only. DO NOT use machine on any surface which will not support the load applied to outrigger foot pad.

Lower all four outriggers until weight of the machine is fully supported by the outriggers and machine is level (green "auto level" light should be on).

Using ground controls, perform operational test of all boom functions.

When working on public roads, warnings and barriers must be set up in accordance with all local, state and federal traffic codes.

ELECTROCUTION HAZARDS
This machine is NOT electrically insulated and DOES NOT provide protection for personnel from contact with, or close proximity to, any live electrical power source and should be considered energized by all personnel coming in contact with machine.

Voltage Range (Phase to Phase)	Minimum Safe Approach Distance (Feet)	(Meters)
0 to 300V	Avoid Contact	
Over 300V to 50KV	10	3.05
Over 50KV to 200KV	15	4.60
Over 200KV to 350KV	20	6.10
Over 350KV to 500KV	25	7.62
Over 500KV to 750KV	35	10.67
Over 750KV to 1000KV	45	13.72

TIP HAZARDS
DO NOT use unless all four outriggers are completely lowered and the machine is level.
DO NOT release outriggers with boom extended or operator occupying platform.
DO NOT exceed rated load capacity.
DO NOT set machine up on any surface unless it can be leveled using only outriggers.
DO NOT use chocks, blocks or shims of any kind to level machine.
DO NOT continue to operate machine if tilt alarm sounds. Retract and lower boom immediately.
DO NOT operate machine in strong or gusty winds.
DO NOT increase surface area of platform. Increasing areas exposed to wind will decrease machine stability.
DO NOT push off or pull on any object outside of the platform.

IF YOU HAVE NOT BEEN PROVIDED WITH SAFETY LITERATURE, OR FOR ANY QUESTIONS CONCERNING THE SAFE USE OF THIS MACHINE, CONTACT YOUR LOCAL BIL-JAX DISTRIBUTOR, OR BIL-JAX, INC. AT 419-445-8915.

B06-00-0471

B06-00-0471

⚠ DANGER

FAILURE TO FOLLOW THESE BATTERY AND CHARGER SAFETY RULES WILL CAUSE SERIOUS INJURY OR DEATH.

ELECTROCUTION HAZARDS
Risk of Electric Shock

- DO NOT expose batteries or charger to water and/or rain.
- DO NOT use frayed or damaged electric cords when charging.
- Connect input cord only to properly grounded three wire outlet with specified voltage and frequency.

BURN HAZARDS

- Batteries contain acid. **Always** wear protective eyewear, face shield and protective clothing when working on or near battery.

EXPLOSION HAZARDS

- DO NOT contact battery terminals or cable clamps with tools that may cause sparks.
- During charging, explosive oxyhydrogen gas is generated.
- DO NOT smoke or allow open fire, sparks, or embers near battery when charging.

COMPONENT DAMAGE HAZARDS

- Keep terminals and terminal connections clean.
- Batteries must be charged using rated voltage noted on serial plate.
- Consult Operators Manual and Parts and Service Manual for additional information on battery maintenance.

B06-00-0034

B06-00-0034

⚠ DANGER

ELECTROCUTION HAZARD

It is unlawful to operate this equipment within 10 feet of high voltage lines of 50,000 volts or less. This machine is NOT insulated. Do not use within 10 ft. of power lines or other electrically charged sources. This machine DOES NOT provide protection for personnel from contact with or close proximity to any live electrical power source and should be considered energized by all personnel coming in contact with machine.

KEEP CLEAR

B06-00-0482

B06-00-0482

⚠ DANGER

BATTERY AND CHARGER OPERATING INSTRUCTIONS

OBSERVE AND FOLLOW

- Do not use external charger or booster battery.
- Recharge batteries after each work shift.
- Use proper AC input voltage for charging as indicated on charger.
- Do not expose charger to water.

TO CHARGE BATTERY

- Remove battery vent caps and check battery fluid level. If necessary, add only enough water to cover the plates. Do not overfill. Replace battery vent caps.
- Be sure battery disconnect plug is connected before charging batteries.
- Connect the battery charger to a grounded AC circuit.
- The charger will automatically shut off when charging cycle is complete.

B06-00-0484

B06-00-0484

⚠ DANGER

TIP-OVER HAZARD

Machine tip-over will cause death or serious injury. Do not alter or disable limit switch(es).

B06-00-0521

B06-00-0521

4527A

B06-00-0539

Haulotte | **BILJAX**

Proudly Made In The USA

0202-0523

0202-0523

B06-00-0161B

AIR
120 PSI

B06-00-0530

B06-00-0530

WATER
3000 PSI

B06-00-0531

B06-00-0531

NOTICE

B06-00-0536

B06-00-0536

DECALS – ANSI (CONTINUED)

⚠ DANGER

FAILURE TO READ, UNDERSTAND AND FOLLOW THESE SAFETY INSTRUCTIONS OR ANY IMPROPER USE OF THIS EQUIPMENT WILL RESULT IN SERIOUS INJURY OR DEATH.

BEFORE USE
Operator is responsible for proper machine operation.

Operator is responsible for proper machine operation.

DO NOT operate this machine unless you have:

- been fully trained in proper operation.
- read and understood Operators Manual.
- read and understood all warning and instruction decals.

Inspect lift for any damaged or worn components (see Operators Manual for complete maintenance and inspection procedures)

NEVER TAKE CHANCES - DO NOT USE this lift if you are under the influence of drugs or alcohol, or if you feel dizzy, ill or unsteady.

SET UP
Survey the jobsite and identify all potential hazards. Operator is responsible to avoid all hazardous situations.

Operate on firm and level surface only.

DO NOT use machine on any surface which will not support the load applied to outrigger foot pad.

Lower all four outriggers until weight of the machine is fully supported by the outriggers and machine is level (green "auto level" light should be on). Using ground controls, perform operational test of all boom functions.

When working on public roads, warnings and barriers must be set up in accordance with all local, state and federal traffic codes.

ELECTROCUTION HAZARDS
This machine is NOT electrically insulated and DOES NOT provide protection for personnel from contact with, or close proximity to, any live electrical power source and should be considered energized by all personnel coming in contact with machine.

Voltage Range (Phase to Phase)	Minimum Safe Approach Distance (Feet)	Minimum Safe Approach Distance (Meters)
0 to 300V	Avoid Contact	
Over 300V to 500V	10	3.05
Over 500V to 2000V	15	4.60
Over 2000V to 3500V	20	6.10
Over 3500V to 5000V	25	7.62
Over 5000V to 7500V	35	10.67
Over 7500V to 10000V	45	13.72

TIP HAZARDS
DO NOT use unless all four outriggers are completely lowered and the machine is level. DO NOT release outriggers with boom extended. DO NOT exceed rated load capacity. DO NOT set machine up on any surface unless it can be leveled using only outriggers.

DO NOT use chocks, blocks or shims of any kind to level machine.

DO NOT continue to operate machine if tilt alarm sounds. Retract and lower boom immediately.

DO NOT operate machine in strong or gusty winds.

DO NOT increase surface area of platform.

Increasing areas exposed to wind will decrease machine stability.

DO NOT push off or pull on any object outside of the platform.

DO NOT place or attach overhanging loads to any part of platform.

DO NOT exceed platform capacity when transferring loads to the platform while elevated.

FALL HAZARDS
DO NOT operate without full body harness and lanyard in use by all platform occupants.

- Attach lanyard to fall protection attachment point provided in platform.
- DO NOT stand, sit or climb on guard rails or top edge of platform.
- DO NOT lean out over top edge of platform guard rails to perform work.
- Maintain a firm footing on the platform at all times.
- DO NOT use boxes, ladders, scaffolding, or any other means to increase working height.
- DO NOT climb up or down boom.
- DO NOT climb down from platform when raised.
- DO NOT allow ropes, electric cords, hoses, or similar objects to become entangled in the machine.
- DO NOT operate machine without platform entry mid-rail fully lowered.
- DO NOT move or reposition machine while platform is raised.

COLLISION HAZARDS
DO NOT use where lift operator can come in contact with overhead obstructions such as electric wires, cables, ropes, overhangs or similar hazards.

To avoid hand injuries, always keep hands inside platform area during boom movement.

MISUSE HAZARDS
DO NOT override, alter, or bypass safety devices.

DO NOT use boom turntable rotation or platform rotation for pushing or pulling.

DO NOT use platform as a crane for lifting materials. Always remove platform and use optional material lifting hook attachment.

DO NOT use when exposed to rain, snow, or other severe weather.

EXPLOSION HAZARDS
DO NOT allow flames, sparks, or embers near batteries.

DO NOT smoke near batteries. Batteries produce a hydrogen-oxygen gas mixture which can explode.

DO NOT smoke while near fuel tank on internal combustion engine.

GENERAL INSTRUCTIONS
Be sure all tires are in good condition, air filled tires are properly inflated and lug nuts are properly tightened.

DO NOT leave keys in machine while unattended.

DRIVE FUNCTION HAZARDS
Maintain an awareness of limited sight and blind spots.

Limit drive speeds according to surface conditions, slope, location of personnel and obstructions.

DO NOT engage in stunt driving or horseplay.

DO NOT operate internal combustion engine in an area that is not ventilated.

IF YOU HAVE NOT BEEN PROVIDED WITH SAFETY LITERATURE, OR HAVE QUESTIONS CONCERNING THE SAFE USE OF THIS LIFT, CONTACT YOUR REGIONAL BIL-JAX DEALER, OR BIL-JAX, INC. AT 800-537-0540.

B06-00-0505

⚠ WARNING

GROUND OPERATING INSTRUCTIONS

UNHITCHING
Machine must be unhitched from vehicle before setting up.

1. Apply parking brake.
2. Remove lighting plug, safety chains and break away cable from vehicle.
3. Release trailer coupler from tow vehicle.
4. Deploy and lower trailer tongue jack.

SETTING UP

1. Read and follow all instructions in Operators Manual and on all decals prior to operation.
2. Check that personnel and obstructions are clear of outriggers.
3. Set key switch to ground controls.
4. Release both emergency stop buttons (ground and platform controls).
5. Deploy outriggers using:
 - AUTO LEVEL**
Press and hold "extend" and "auto level" button simultaneously, or
 - MANUAL LEVEL**
Deploy the two outriggers closest to the trailer coupler first. Manually lower each outrigger by pressing "extend" and the individual outrigger buttons simultaneously.
6. When properly leveled, two lights at each outrigger button and the light at the "auto level" button will be on.

Improper use of this equipment will result in serious injury or death. This machine must not be operated unless you are completely familiar with and follow all instructions contained in the Operators Manual.

ARTICULATING MODEL

OPERATING INSTRUCTIONS

1. Unclamp boom transport latch(es).
2. Check all functions for proper operation.
 - Set key switch to ground controls.
 - Release both emergency stop buttons (ground and platform controls).
 - Select function and speed by pressing the appropriate buttons simultaneously.
3. Fully retract, then lower boom to stowed position. Move key switch to platform controls. Lift is now ready for operation from the platform.

When using optional material lifting hook, see Operators Manual for instructions.

WARNING DEVICE
Tilt alarm will sound if boom becomes out of level. If this occurs, operator must immediately:

1. Retract extension boom.
2. Rotate and lower platform into stowed position.
3. Check outrigger footing and relevel lift.

EMERGENCY STOP
Push in red emergency stop button to stop all functions.

EMERGENCY LOWERING
Emergency lowering can only be accomplished from the ground.

1. Open cover on opposite side of ground control panel.
2. Locate instruction decal.
3. Follow instructions for Auxiliary/Manual Boom Rotation, Retraction and Lowering.

STOWING LIFT

1. Retract extension boom.
2. Rotate and lower platform into stowed position.
3. Engage and lock boom transport latch(es).
4. Fully raise outriggers using:
 - AUTO RETRACT**
Press and hold "retract" and "auto level" button simultaneously, or
 - INDIVIDUAL RETRACT**
Retract the two outriggers farthest from the trailer coupler first. Raise each outrigger by pressing "retract" and the individual outrigger buttons simultaneously.

TOWING
Before towing, boom must be in stowed position. See stowing lift section.

1. Secure trailer coupler to towing vehicle.
2. Attach safety chains, break away cable and lighting plugs to tow vehicle. Secure for safe transit.
3. Confirm all lights are working properly.
4. Fully raise and stow trailer tongue jack.
5. Release parking brake.
 - Trailer weight must not exceed vehicle towing capacity.
 - Do not exceed maximum towing speed.

B06-00-0533

⚠ WARNING

PLATFORM OPERATING INSTRUCTIONS

Improper use of this equipment will result in serious injury or death. This machine must not be operated unless you are completely familiar with and follow all instructions contained in the Operators Manual.

OPERATING INSTRUCTIONS

1. Read and follow all instructions in Operators Manual and on all decals prior to operation.
2. Follow the instructions on the ground controls for "Unhitching", "Setting Up" and "Operating Instructions".
3. Verify outriggers are properly set and lift is level.
4. Always wear full body harness and attach lanyard to the fall protection attachment.
5. Both emergency stop buttons (ground and platform controls) should be in the released position.
6. Press and hold the desired function and speed button simultaneously.

EMERGENCY STOP
Push in red emergency stop button to stop all functions.

WARNING DEVICE
Tilt alarm will sound if boom becomes out of level. If this occurs, operator must immediately:

1. Retract extension boom.
2. Rotate and lower platform into stowed position.
3. Check outrigger footing.
4. Relevel lift.

B06-00-0534

⚠ WARNING

CRUSH HAZARD



Stand clear of outrigger being lowered or raised. Contact with outrigger will cause serious crushing injury.

B06-00-0404

DECALS – ANSI (CONTINUED)

⚠ WARNING

TOWING HAZARDS

Read, understand and follow all of the tow vehicle manufacturer's recommendations, warnings and instructions before towing this trailer.

Do not exceed maximum towing speed: 65 mph/105 km/h

Do not exceed Gross Vehicle Weight Rating (GVWR).

Do not exceed the vehicle tow rating.

Do not exceed the Gross Combination Weight Rating (GCWR).

Do not exceed the Gross Axle Weight Rating (GAWR).

Be sure safety chains are securely attached to tow vehicle.

Failure to read, understand and follow these safety rules will result in property damage, serious injury or death.

Do not transport machine unless all transport latches have been engaged and locked.

Tongue jack must be raised and stowed.

Parking brake must be released.

Do not load cargo on trailer.

Be sure coupler is securely attached to tow vehicle and hitch ball is securely attached to hitch.

Be sure that all lights are operational.

Be sure all lights and hitch components conform to Federal and local regulations.

Be sure tires are properly inflated.

UTA
B06-00-0544

B06-00-0544

⚠ WARNING

LIFT MUST BE UNHITCHED FROM TOW VEHICLE PRIOR TO OUTRIGGER DEPLOYMENT.

TIP OVER HAZARD

Failure to comply with the above instruction may result in lift tip over causing injury or death to operator.

DAMAGE HAZARD

Failure to comply with the above instruction may result in damage.

UTA
B06-00-0550

B06-00-0550

⚠ WARNING

PINCH POINT HAZARD

STAY CLEAR

UTA
B06-00-0405

B06-00-0405

⚠ WARNING

Failure to read, understand and follow enclosed Operators Manual may result in serious injury or death.

UTA
B06-00-0475

B06-00-0475

⚠ WARNING

MAXIMUM TOWING SPEED:

65 mph / 105 km/h

Follow all local and national towing speed regulations.

UTA
B06-00-0542

B06-00-0542

⚠ WARNING

CRUSH HAZARD

Keep feet clear of tires when retracting outriggers. Failure to comply with this will result in a serious crushing injury.

UTA
B06-00-0543

B06-00-0543

⚠ WARNING

FORK LIFT USE

Engage and lock boom transport latch(es) before lifting.

Do not exceed forklift lifting capacity.

Fully insert forks into pockets.

Failure to follow all forklift rules and instructions will result in property damage, serious injury or death.

UTA
B06-00-0477

B06-00-0477

⚠ CAUTION

All boom sections must be fully retracted then completely lowered to tow.

All transport latches must be fully engaged and locked.

UTA
B06-00-0481

B06-00-0481

⚠ CAUTION

COMPARTMENT ACCESS IS RESTRICTED

Improper contact with components under any cover will cause serious injury.

Only trained and authorized maintenance personnel should access compartments.

Access by operator is only advised when performing preoperation inspection. All compartments must remain closed and secured during operation and transport.

UTA
B06-00-0495

B06-00-0495

⚠ CAUTION

PRIOR TO TOWING INSTRUCTIONS

Failure to follow all towing instructions below will cause damage to equipment and/or tow vehicle.

Note: Lift must be hitched to tow vehicle prior to raising jack stand.

<p>Secure lower boom transport latch.</p>	<p>Secure upper boom transport latch.</p>
<p>Raise and secure jack stand.</p>	<p>Release parking brake.</p>

UTA
B06-00-0551

B06-00-0551

⚠ CAUTION

MANUAL BOOM FUNCTIONS

- Turn proportional valve (figure 1) counterclockwise until it stops.
- Insert pump handle into hand pump (figure 2).

MANUAL RETRACTION

Push and hold retract button (figure 3) and simultaneously pump hand pump.

MANUAL ROTATION

To rotate clockwise: Push and hold rotation button (figure 4) and simultaneously pump hand pump.

To rotate counterclockwise: Pull rotation button out (figure 4) and simultaneously pump hand pump.

NOTE: Turn proportional valve clockwise into original position prior to manual lowering or lift operation.

MANUAL LOWERING

Lower each boom individually by pushing the release valve located on each cylinder.

UTA
B06-00-0541

B06-00-0541

⚠ CAUTION

GENERATOR MOUNTING PLATE

Maximum Load:

200 lbs. / 91 kg

Secure equipment on plate.

Do not exceed maximum load capacity. Unsecured or overloaded cargo will cause damage and serious injury.

UTA
B06-00-0496

B06-00-0496

LUBRICATE SEMI-ANNUALLY

COIA
B06-00-0037

B06-00-0037

NOTICE

FALL PROTECTION ATTACHMENT POINTS

LIMIT ONE PERSON PER ATTACHMENT POINT. LANYARDS SHOULD NOT EXCEED 6ft (2m) IN LENGTH.

UTRAJCC
B06-00-0552

B06-00-0552

NOTICE

EMERGENCY HAND PUMP HANDLE INSERTION

UTA
B06-00-0504

B06-00-0504

NOTICE

AC power connection for platform and charger.

UTA
B06-00-0478

B06-00-0478

DECALS – ANSI (CONTINUED)

NOTICE

The hydraulic system of this machine is designed to use AW32 hydraulic oil with a viscosity index of 190 or higher.

Rev 4 B06-00-0068

B06-00-00068

NOTICE

EMERGENCY LOWERING VALVE

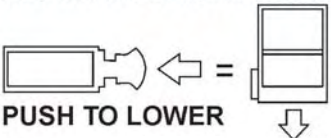

PUSH TO LOWER

Rev 2 B06-00-0403

B06-00-0403

NOTICE

If Operators Manual is missing, please contact your regional Haulotte dealer or Haulotte Services at 888-440-9240.

LTAVGCC B06-00-0473

B06-00-0473

NOTICE

Handle should be used for the following applications:

- Manual Hand Pump
- Tire Iron

Rev 2 B06-00-0503

B06-00-0503

NOTICE

Not Equipped with Platform Rotation and/or Jib Rotate Total of occupants and equipment must not exceed 500 lbs. / 227 kg.	Maximum Load: 500 lbs. / 227 kg
Equipped with Platform Rotation and/or Jib Rotate Total of occupants and equipment must not exceed 440 lbs. / 200 kg.	Maximum Occupants: 2
	Maximum Load: 440 lbs. / 200 kg
	Maximum Occupants: 2

Rev 2 B06-00-0474

B06-00-0474

NOTICE

One or more of the following hazardous materials are used on this machine:

- Gasoline
- Liquid Petroleum Gas (LPG)
- Diesel Fuel
- Hydraulic Fluid
- Antifreeze
- Engine Oil
- Grease
- Lead Acid Battery

Rev 1 B06-00-0494

B06-00-0494

NOTICE

AC POWER



Rev 1 B06-00-0062

B06-00-0062

NOTICE

UNLEADED FUEL ONLY



LTAV B06-00-0487

B06-00-0487

WARNING

DRIVE AND SET HAZARDS Failure to read, understand and obey the following instructions may result in serious injury or death.

TIP-OVER HAZARD Use extreme care and slow speeds while driving machine in stowed positions across uneven terrain, debris, unstable or slippery surfaces. Do not drive near holes or drop-offs.	COLLISION HAZARDS Do not drive machine unless parking brake is set. Do not drive machine from ground. Platform must be fully lowered and the operator must be in platform. Be aware of limited sight distance and blind spots when driving or operating. Observe and use direction arrows on platform controls for drive and steer functions. Limit travel speed according to condition of ground surface, congestions, slope, location of personnel and any other factors which may cause collision.
--	---

CTH B06-00-0527

B06-00-0527

CAUTION

COMPONENT DAMAGE HAZARD
Prior to transport, close the fuel shut-off valve. Open valve for operation. Failure to close the fuel shut-off valve before transporting machine may result in engine damage.

LTAV B06-00-0488

B06-00-0488

NOTICE

Engine Specifications:
Honda GX270 VDE2 9.0 HP
Oil: SAE 10W-30
Oil Capacity: 1.16 qt / 1.1 Ltr
Air Filter:
Honda 17210-ZE3-010
Honda 17210-ZE3-505
Engine RPM
Low idle: 1600-1800 rpm
High idle: 3600 rpm

COITA B06-00-0486

B06-00-0486

NOTICE

DRIVE AND SET INSTRUCTION Parking brake on tongue must be set to operate drive system.

COMPLETELY LOWER PLATFORM Drive function will not operate unless platform is fully lowered.	DRIVE FROM PLATFORM INSTRUCTION Press and hold drive enable button; move joystick in the desired direction. Release drive enable button or joystick to stop.
SET PARKING BRAKE ON TONGUE Drive function will not operate unless parking brake on tongue is set.	TO RAISE PLATFORM Deploy all outriggers. Using ground or platform controls, hold enable button and press extend. When level, machine level light will illuminate and confirming beep will sound. Machine must be set and level to operate boom functions.
RETRACT OUTRIGGERS All outriggers must be fully retracted prior to drive function.	

CTH B06-00-0528

B06-00-0528

NOTICE

MATERIAL LIFTING CONFIGURATION

- Release clamp on the back of the platform control box and remove it from the bracket. Disconnect plug from the load sense module. Take box to area near ground controls.
- Open turntable cover at ground controls.
- Remove electric plug from bottom right of ground controls and insert platform control connection. Insert removed electric plug into load sense module where platform control box was connected. Close turntable cover.
- Secure platform while removing pin holding platform to boom.
- Lift platform up and remove from machine.
- Remove pin securing material lifting hook to base. Release material lifting hook.
- Insert material lifting hook into the bottom rail of the platform mounting bracket and rotate up into position. Insert clevis pin.
- Operate material lifting hook from ground with platform control box for optimal control. If using ground controls, be certain keyswitch is in correct position.
- Reverse above process to convert machine to personnel lift.

CTH B06-00-0485

B06-00-0485

WARNING

JOCKEY WHEEL INSTRUCTION FOR DRIVE AND SET OPTION
Failure to follow instructions in the order listed below will result in equipment damage, serious injury or death.

1. Set parking brake. Lower jack stand and unhitch lift from tow vehicle. Move tow vehicle away from lift.
2. Remove lock pin on jockey wheel and swing into lowered position. (fig. 1) Insert lock pin to secure the jockey wheel in lowered (drive) position.
3. Raise jack stand and swing into stowed position. (fig. 2)
4. Lift is ready for drive functions.
5. To prepare lift for towing, reverse instructions prior to hitching.

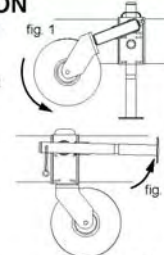

LTAV B06-00-0553

B06-00-0553

WARNING

Failure to read, understand and obey the following safety rules could result in serious injury or death.

DO NOT TOUCH



HOT SURFACE

ENGINE OPERATION
Do not operate engine indoors. When indoors, operate machine using battery power only. This machine can be operated with or without the engine running. Start engine by pressing engine start button. In cold conditions, hold choke down and press engine start. See Operator's Manual for additional instruction.

COITAVGCC B06-00-0547

B06-00-0547

NOTICE

MATERIAL LIFTING HOOK
Maximum Load:
500 lbs / 227 kg

LTAV B06-00-0497

B06-00-0497

NOTICE

PLATFORM ROTATION
Turn handle in direction of desired rotation.



LTAV B06-00-0529

B06-00-0529

DECAL KIT - CE

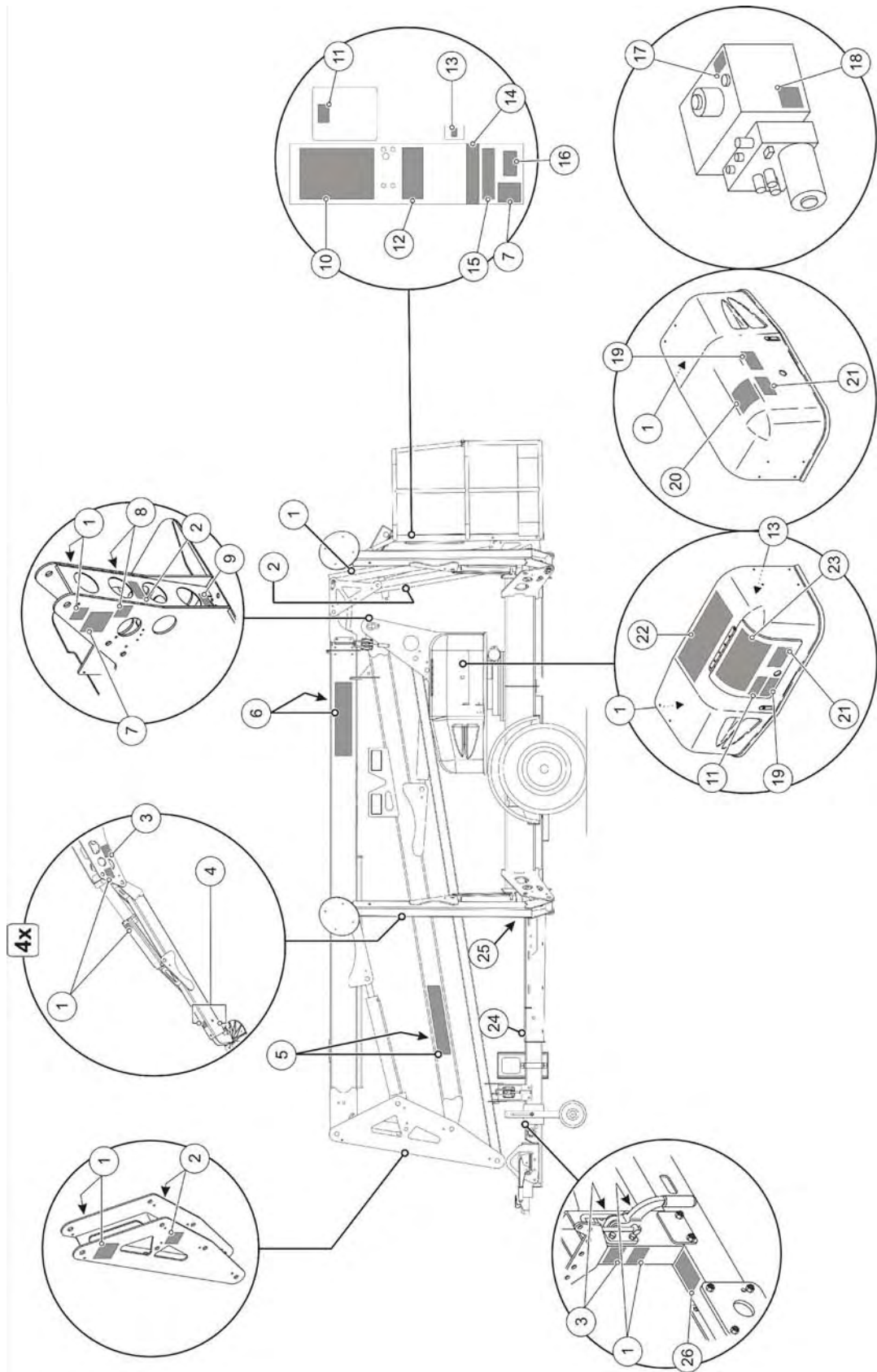

DECAL KIT – CE

B06-01-4020		DECAL KIT - Includes the following:	
ITEM NO.	PART NUMBER	DESCRIPTION	QTY.
1	B06-00-0405-CE	Decal - Warning - Hand Pinch Point	15
2	B06-00-0403-CE	Decal - Notice - Emergency Lower	4
3	B06-00-0568-CE	Decal - Caution - Outrigger Pressure	4
4	B06-00-0404-CE	Decal - Warning - Outrigger Crush Foot	10
5	B06-00-0161B	Decal - 'Haulotte BilJax' - 5in Black / Red on Clear	2
8	B06-00-0482-CE	Decal - Danger - Electrocutation	2
11	B06-00-0475-CE	Decal - Warning - Read / Understand Manual	2
13	B06-00-0062-CE	Decal - Notice - AC Power	2
14	B06-00-0173-CE	Decal - Notice - Lanyard Attachment	1
15	B06-00-0474-CE	Decal - Notice - Platform Maximum Load	1
16	0202-0523	Decal - Flag, Made In USA	1
17	B06-00-0068-CE	Decal - Notice - Low Foam Hydraulic Oil	1
19	B06-00-0495-CE	Decal - Caution - Compartment Access	2
20	B06-00-0572-CE	Decal - Caution - Read Parts and Service Manual	1
21	B06-00-0034-CE	Decal - Danger - Battery / Charger Safety	2
24	B06-00-0496-CE	Decal - Caution - Generator Plate Maximum 200	1
26	B06-00-0542-CE	Decal - Warning - Maximum Tow Speed 65	1

B06-01-4023		DECAL KIT - Includes the following:	
ITEM NO.	PART NUMBER	DESCRIPTION	QTY.
6	B06-00-0539-CE	Decal - HTA 16 P - Black Clear Vinyl with Black Letters	2
7	B06-00-0536-CE	Decal - Notice - Range of Motion - 4527A	2

B06-01-4021-DU DECAL KIT - Dutch - Includes the following:

B06-01-4021-EN DECAL KIT - English International - Includes the following:

B06-01-4021-FC DECAL KIT - French (Canadian) - Includes the following:

B06-01-4021-FR DECAL KIT - French (European) - Includes the following:

B06-01-4021-GE DECAL KIT - German - Includes the following:

B06-01-4021-IT DECAL KIT - Italian - Includes the following:

B06-01-4021-KO DECAL KIT - Korean - Includes the following:

B06-01-4021-RU DECAL KIT - Russian - Includes the following:

B06-01-4021-SW DECAL KIT - Swedish - Includes the following:

ITEM NO.	PART NUMBER	DESCRIPTION	QTY.
9	B06-00-0037	Decal - "Lubricate Semi - Annually"	1
10	B06-00-0471	Decal - Danger - Main Instruction / Hazard - Platform	1
12	B06-00-0534	Decal - Warning - Platform Operation - 4527A	1
18	B06-00-0541	Decal - Caution - Manual Rotate / Retract	1
22	B06-00-0505	Decal - Danger - Main Instruction / Hazard - Base	1
23	B06-00-0533	Decal - Warning - Ground Operation	2
25	B06-00-0478	Decal - Notice - AC Power Connection	1

Note: Decals without the CE suffix are available in the following languages:

-DE = German, -DU = Dutch, -FC = French (Canadian), -FR = French (European), -IT = Italian,
-KO = Korean, RU = Russian, -SP = Spanish, -SW = Swedish

To order add the appropriate suffix to the end of the part number.

IDENTIFICATION PLATES & OPTIONAL EQUIPMENT - CE

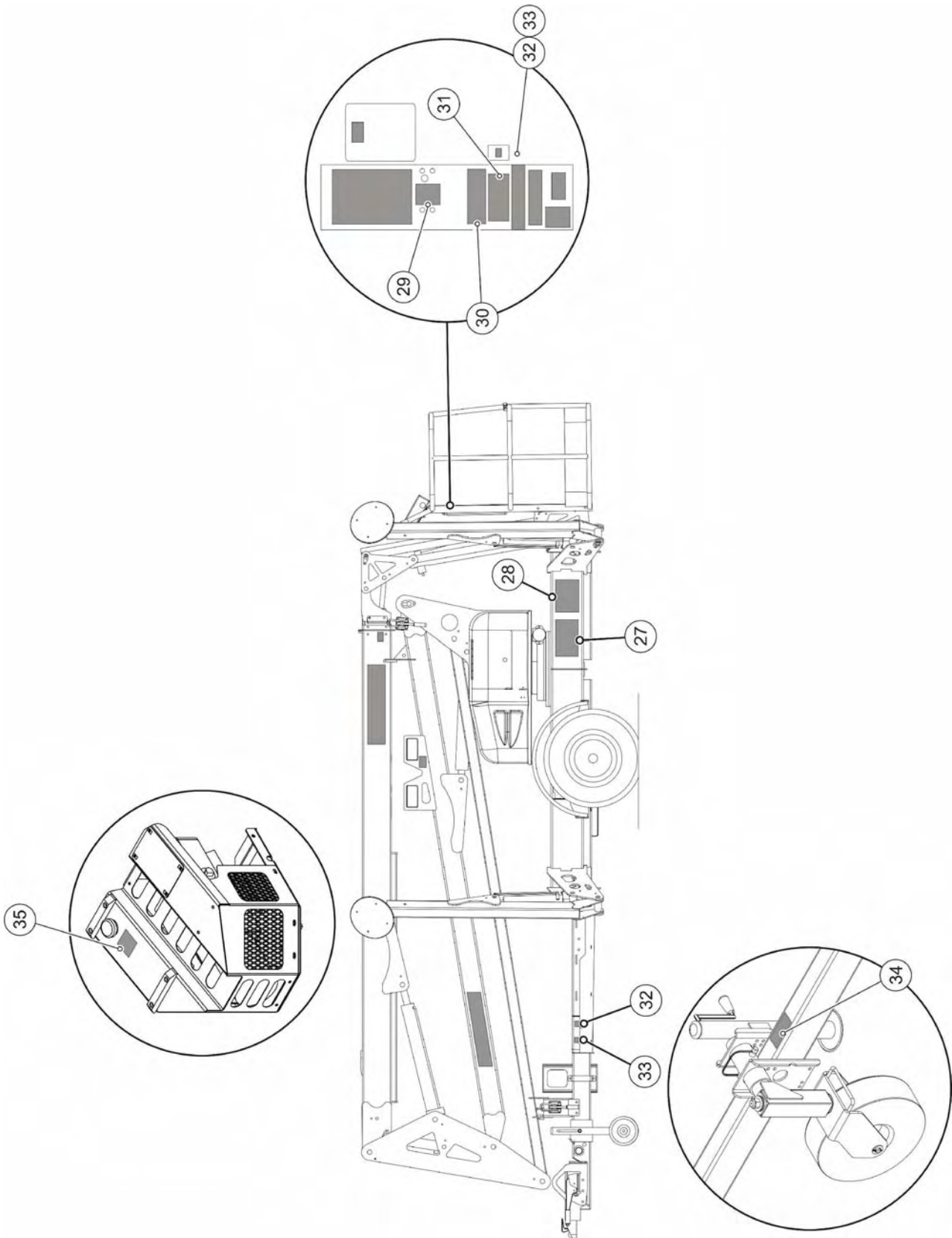

IDENTIFICATION PLATES & OPTIONAL EQUIPMENT - CE**IDENTIFICATION PLATES – CE (Used on all standard CE equipment)**

ITEM NO.	PART NUMBER	DESCRIPTION	QTY.
27	B06-00-0499-CE	ID Plate	1
28	B06-00-0490	VIN Plate	1

DECALS FOR OPTIONAL EQUIPMENT – CE

ITEM NO.	PART NUMBER	DESCRIPTION	QTY.
29	B06-00-0529	Decal - Notice - Platform Rotate (Manual Rotation Option)	1
30	B06-00-0527	Decal - Warning - Drive and Set (Drive and Set Option)	1
31	B06-00-0528	Decal - Notice - Drive and Set (Drive and Set Option)	1
32	B06-00-0530	Decal - Air - 120 PSI (Air Line to Platform Option)	2
33	B06-00-0531	Decal - Water - 3000 PSI (Water Line to Platform Option)	2
34	B06-00-0553	Decal - Warning - Jockey Wheel (Drive and Set Option)	1
35	B06-00-0487	Decal - Notice - Unleaded Fuel Only (Gas Engine Option)	1

DECAL KIT - AU

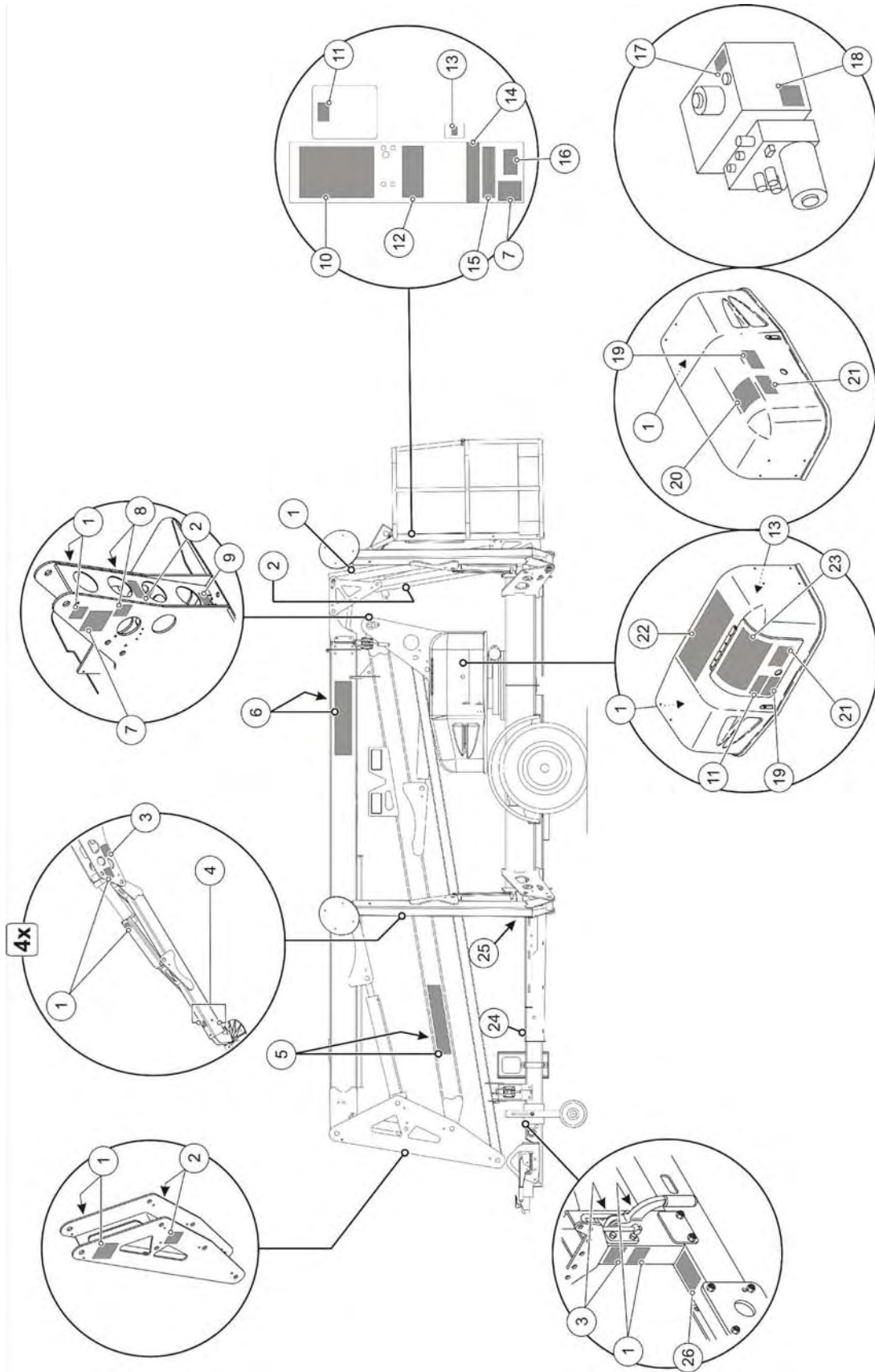

DECAL KIT - AU

B06-01-4020		DECAL KIT - Includes the following:	
ITEM NO.	PART NUMBER	DESCRIPTION	QTY.
1	B06-00-0405-CE	Decal - Warning - Hand Pinch Point	15
2	B06-00-0403-CE	Decal - Notice - Emergency Lower	4
3	B06-00-0568-CE	Decal - Caution - Outrigger Pressure	4
4	B06-00-0404-CE	Decal - Warning - Outrigger Crush Foot	10
5	B06-00-0161B	Decal - 'Haulotte BilJax' - 5in Black / Red on Clear	2
8	B06-00-0482-CE	Decal - Danger - Electrocution	2
11	B06-00-0475-CE	Decal - Warning - Read / Understand Manual	2
13	B06-00-0062-CE	Decal - Notice - AC Power	2
14	B06-00-0173-CE	Decal - Notice - Lanyard Attachment	1
15	B06-00-0474-CE	Decal - Notice - Platform Maximum Load	1
16	0202-0523	Decal - Flag, Made In USA	1
17	B06-00-0068-CE	Decal - Notice - Low Foam Hydraulic Oil	1
19	B06-00-0495-CE	Decal - Caution - Compartment Access	2
20	B06-00-0572-CE	Decal - Caution - Read Parts and Service Manual	1
21	B06-00-0034-CE	Decal - Danger - Battery / Charger Safety	2
24	B06-00-0496-CE	Decal - Caution - Generator Plate Maximum 200	1
26	B06-00-0542-CE	Decal - Warning - Maximum Tow Speed 65	1

B06-01-4023		DECAL KIT - Includes the following:	
ITEM NO.	PART NUMBER	DESCRIPTION	QTY.
6	B06-00-0539-CE	Decal - HTA 16 P - Black Clear Vinyl with Black Letters	2
7	B06-00-0536-CE	Decal - Notice - Range of Motion - 4527A	2

B06-01-4021-EN		DECAL KIT - English International - Includes the following:	
ITEM NO.	PART NUMBER	DESCRIPTION	QTY.
9	B06-00-0037	Decal - "Lubricate Semi - Annually"	1
10	B06-00-0471	Decal - Danger - Main Instruction / Hazard - Platform	1
12	B06-00-0534	Decal - Warning - Platform Operation - 4527A	1
18	B06-00-0541	Decal - Caution - Manual Rotate / Retract	1
22	B06-00-0505	Decal - Danger - Main Instruction / Hazard - Base	1
23	B06-00-0533	Decal - Warning - Ground Operation	2
25	B06-00-0478	Decal - Notice - AC Power Connection	1

IDENTIFICATION PLATES & OPTIONAL EQUIPMENT - AU

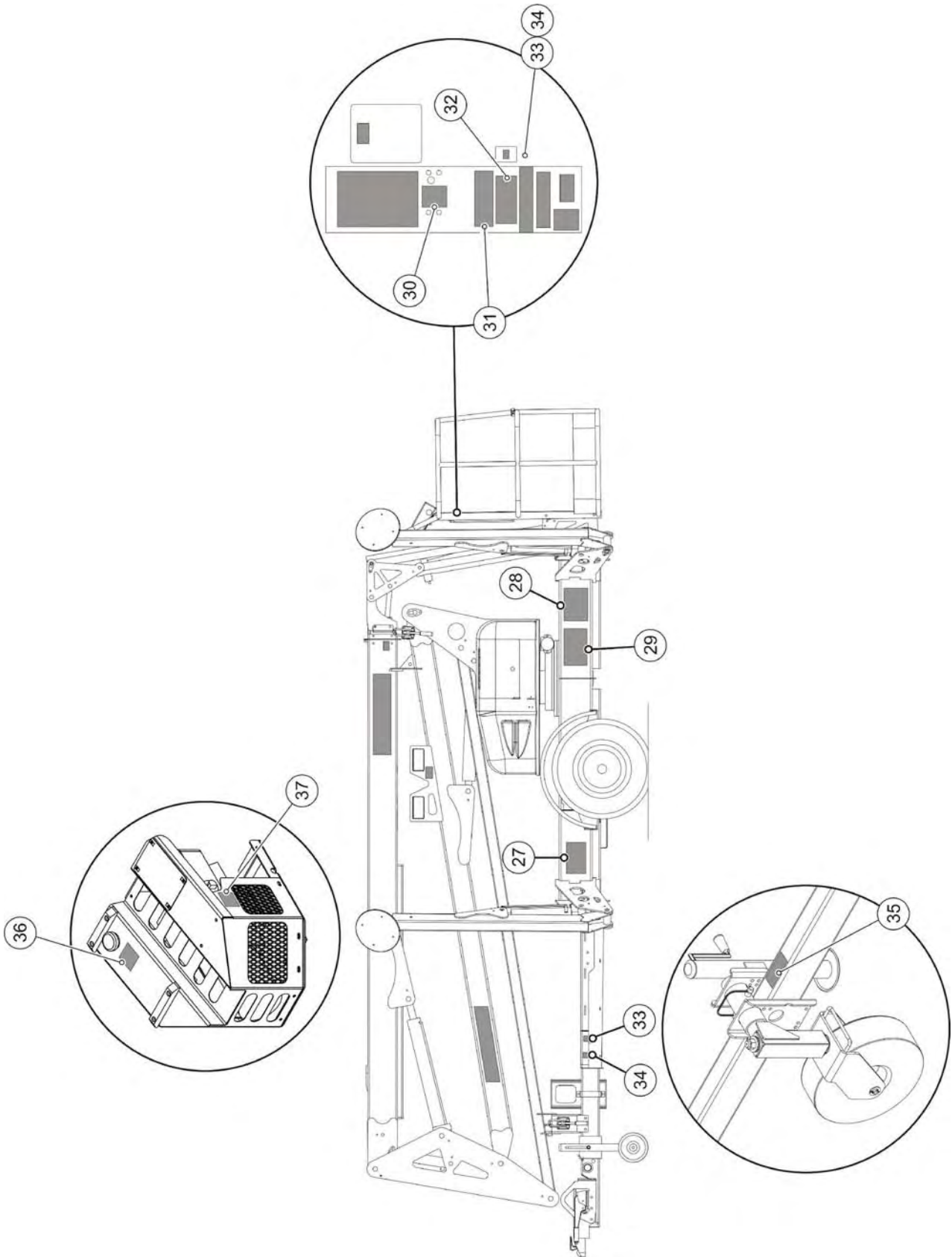

IDENTIFICATION PLATES & OPTIONAL EQUIPMENT - AU

IDENTIFICATION PLATES (Used on all standard equipment)

ITEM NO.	PART NUMBER	DESCRIPTION	QTY.
27	B06-00-0524	Annual Inspection Plate	1
28	B06-00-0490	VIN Plate	1
29	B06-00-0499	ANSI ID Plate	1

REPLACEMENT DECALS FOR OPTIONAL EQUIPMENT

ITEM NO.	PART NUMBER	DESCRIPTION	QTY.
30	B06-00-0529	Decal - Notice - Platform Rotate (Manual Rotation Option)	1
31	B06-00-0527	Decal - Warning - Drive and Set (Drive and Set Option)	1
32	B06-00-0528	Decal - Notice - Drive and Set (Drive and Set Option)	1
33	B06-00-0530	Decal - Air - 120 PSI (Air Line to Platform Option)	2
34	B06-00-0531	Decal - Water - 3000 PSI (Water Line to Platform Option)	2
35	B06-00-0553	Decal - Warning - Jockey Wheel (Drive and Set Option)	1
36	B06-00-0487 - OR - B06-00-0498	Decal - Notice - Unleaded Fuel Only (Gas Engine Option) - OR - Decal - Notice - Diesel Fuel Only (Diesel Engine Option)	1
37	B06-00-0547	Decal - Warning - Eng Operate - Hot (Engine Option)	1

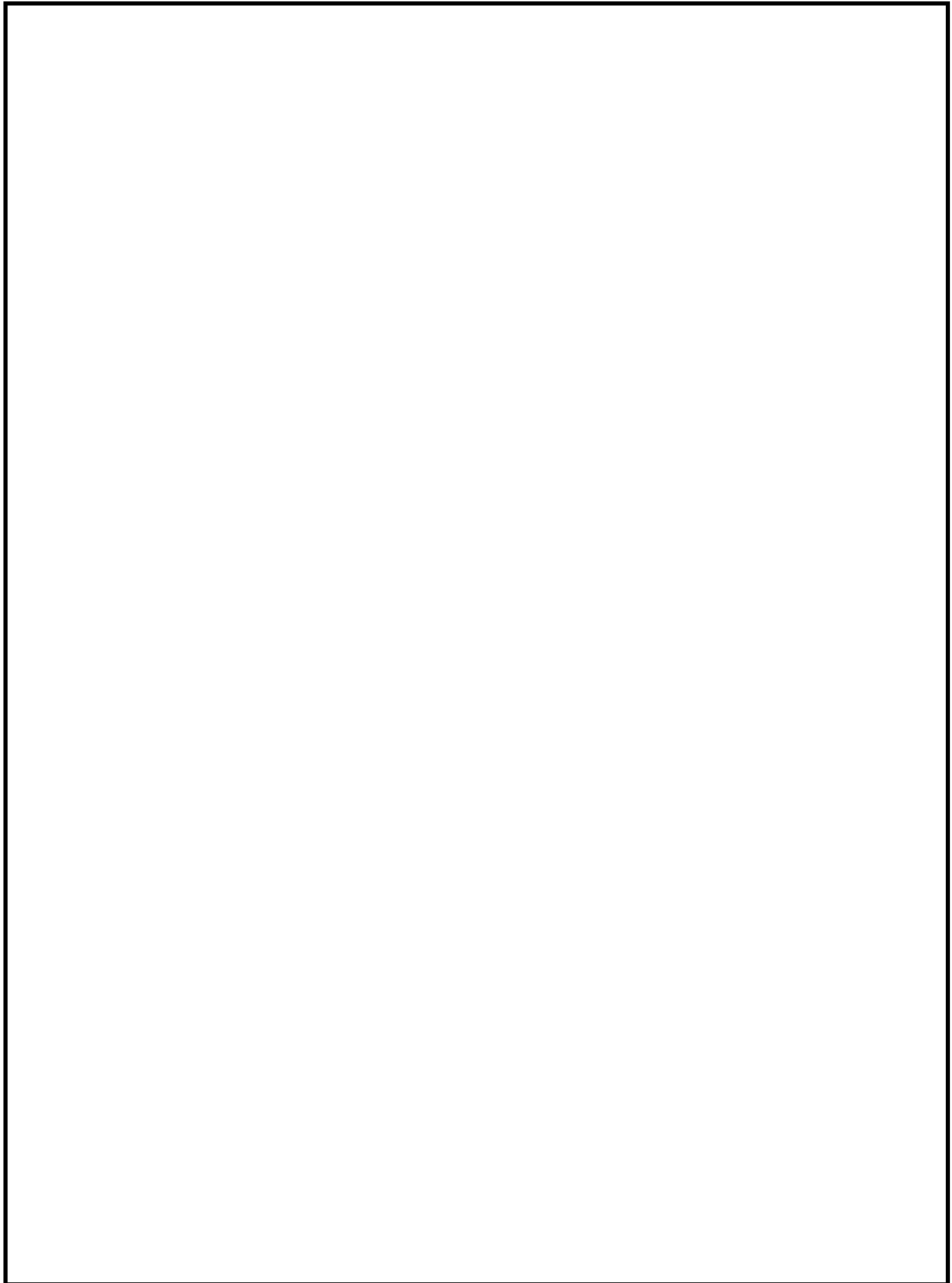

7 OPTIONAL EQUIPMENT

The Haulotte Model 4527A / HTA 16 P is a Summit Series™ trailer-mounted aerial work platform that may be may be equipped with one or more optional components designed for the convenience and safety of operators when using the equipment to accomplish specific tasks.

Always use only those components manufactured and / or authorized by Haulotte Group. Never make any adjustments or modifications or otherwise alter the equipment in any way that is not expressly recommended and / or approved by the manufacturer.

When operating an aerial work platform equipped with optional components, observe all safety precautions set forth by the manufacturer, as well as all Federal, State, and Local codes and regulations regarding this equipment and its components.

Consult rental agency or manufacturer regarding which optional components may be installed on the aerial work platform. For questions regarding safe use, contact Haulotte Group Customer Service Department: at 1-800-537-0540 or visit Haulotte Group online at www.haulotte-usa.com.

DRIVE AND SET

The Drive and Set Option allows the operator to drive the aerial work platform over a short distance on level ground, deploy, retract and level the outriggers from the platform (upper) control panel. The platform (upper) control panel, which has additional controls added, is used to control all boom motions, as well as all Drive and Set functions. The platform (upper) control panel is activated by turning the **KEY SWITCH (1)** at the ground (lower) control panel, clockwise to the **PLATFORM (1b)** icon and entering the platform using a three (3) point contact (both hands and one foot).

DRIVE AND SET SAFETY

NEVER drive the aerial work platform unless the parking brake is set.

NEVER drive the aerial work platform without the platform and boom fully lowered, and the outriggers fully retracted in the “stowed” (upright) position.

NEVER drive the aerial work platform without the operator fully secured inside the platform.

NEVER operate the Drive function on grades exceeding 4.5°. This optional feature is intended to help reposition the aerial work platform, by driving short distances only on a level ground.

NEVER operate the aerial work platform with more than one (1) person in the platform.

ALWAYS watch for personnel and obstructions in the path of the machine. Be aware of limited visibility and blind spots.

DRIVE AND SET CONTROLS

The platform (lower) control panel of a Drive and Set equipped aerial work platform includes the following controls and indicators. Refer to Figure 7-1.

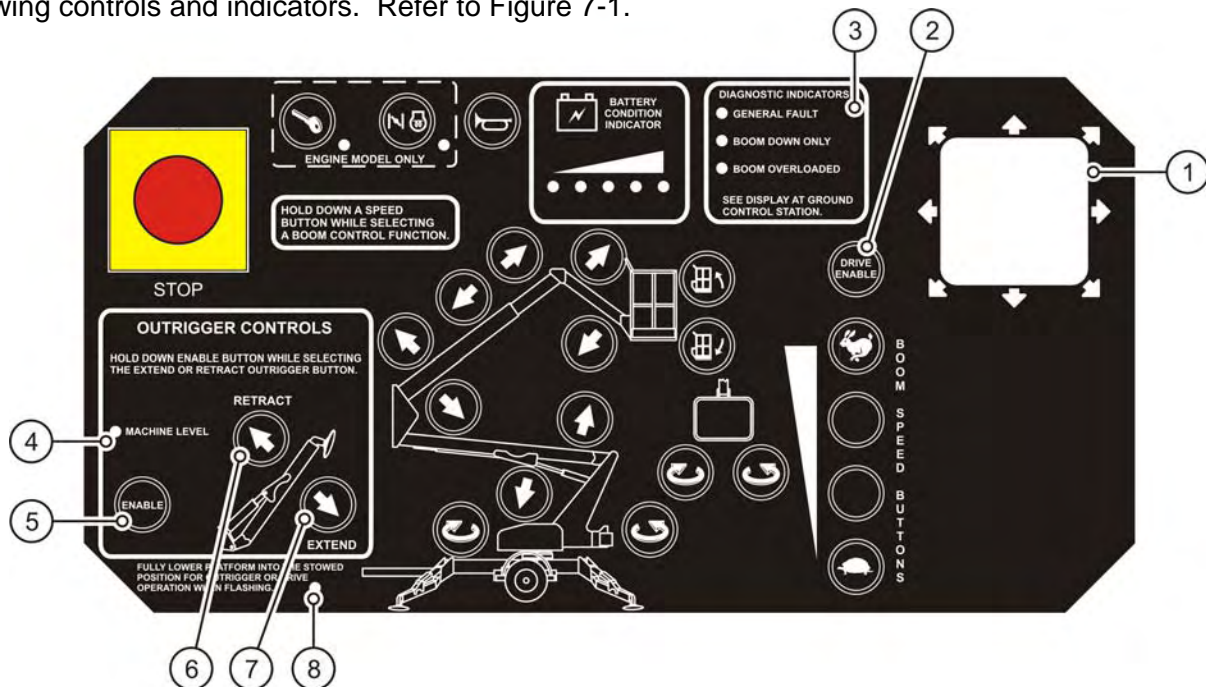

Figure 7-1. Drive and Set Controls

1. Drive and Set Joystick.

The multi-axis **JOYSTICK (1)** drives the aerial work platform in the direction of movement. The **JOYSTICK (1)** only functions when the **DRIVE ENABLE (2)** button is pressed (pushed in) and held. The aerial work platform stops when either the **DRIVE ENABLE (2)** button or **JOYSTICK (1)** is released.

DRIVE & SET CONTROLS (CONTINUED)

2. Drive Enable Button.

Press (push) in and hold the **DRIVE ENABLE (2)** button to activate the **JOYSTICK (1)**. To stop, release either the **DRIVE ENABLE (2)** button or the **JOYSTICK (1)**.

3. Diagnostic Indicators.

DIAGNOSTIC INDICATOR LEDS (3) will light up to indicate that an error in boom lift or drive function has occurred. When lit, check the **DISPLAY PANEL (5)** on the ground (lower) control panel for an error code. Refer to Table 4-3 Error Code Definitions, located in the "Equipment Maintenance" section of this manual.

4. Machine Level Indicator.

The machine **LEVEL INDICATOR LED (6)** will light up to indicate that the aerial work platform is level and boom functions can be performed.

5-7. Outrigger Controls.

The outrigger **ENABLE (5)** button works in tandem with both the outrigger **RETRACT (6)** button and the outrigger **EXTEND (7)** button.

Pressing (pushing) in and holding the **ENABLE (5)** button while pressing (pushing) in on the **RETRACT (6)** button fully retracts all four (4) outriggers simultaneously.

Pressing (pushing) in and holding the **ENABLE (5)** button while pressing (pushing) in on the **EXTEND (7)** button fully deploys all four (4) outriggers simultaneously.

NOTE: The outriggers can be deployed and / or retracted from either the ground (lower) or platform (upper) control panel on aerial work platforms with the Drive and Set Option.

8. Platform Position LED.

When the **PLATFORM POSITION LED (7)** is flashing, the boom must be fully retracted and in the "stowed" position before resuming outrigger control or drive and set operations.

DRIVE AND SET USE

Initial Operation

Use the following procedure to operate the Drive and Set option upon arriving on site.

- Set the parking brake. Drive functions will not operate unless the parking brake is set.
- Lower the **TONGUE JACK / DOLLY WHEEL** and unhitch the aerial work platform from tow vehicle.
- Enter the work platform using a three (3) point contact (both hands and one foot), put on a safety harness and attach the lanyard to the **ANCHORAGE (attachment point)** on the side of the platform support beam.
- Press (push) in and hold the **DRIVE ENABLE (2)** button on the platform (upper) control panel, move the **JOYSTICK (1)** in the desired direction.
- The aerial work platform will continue to move in the desired direction until the **JOYSTICK (1)** or **DRIVE ENABLE (2)** button is released.
- Once you have reached the work location, lower the outriggers, and level the aerial work platform using either the ground (lower) or platform (upper) control panel.

NOTE: Boom functions are not available until all outriggers are fully deployed and the aerial work platform is level.

DRIVE AND SET USE (CONTINUED)

During Operation

Utilize the Drive and Set option to advance to the next work location. Use the following procedure to operate the Drive and Set option.

- Completely lower the platform into its “stowed” position.
- Fully retract outriggers into their “stowed” (upright) position.

NOTE: The aerial work platform **MUST** be in its fully lowered “stowed” position, before moving.

- Press (push) and hold the **DRIVE ENABLE** button on the platform (lower) control panel, move the **JOYSTICK** in the desired direction.
- The Aerial work platform will continue to move in the desired direction until the **JOYSTICK** or **DRIVE ENABLE** button is released.
- To continue platform operations, lower outriggers and level the aerial work platform using either the ground (lower) or platform (upper) control panel.

NOTE: Boom functions are not available until outriggers are fully deployed and the aerial work platform is level.

MATERIAL LIFT HOOK

If an aerial work platform is equipped with the Material Lift Hook option, several steps need to be performed to change from the Platform to the Lift Hook. Use the follow procedure to make this change.

- Unwind the platform (upper) control box's six foot (6') cord from the cord wrap on the platform.
- Disconnect the platform (upper) control box's **PLUG**; from the **LOAD SENSE MODULE**, located on the **PLATFORM MOUNT**. Refer to Figure 7-2

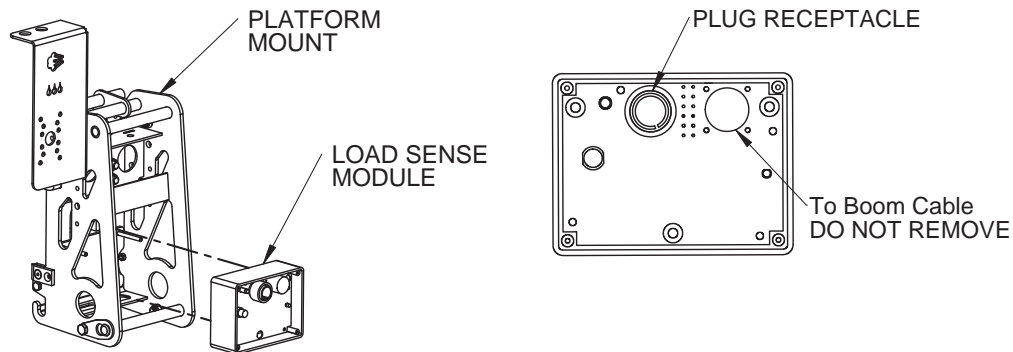

Figure 7-2. Disconnect Plug from Load Sense Module

- Remove the platform (upper) control box from the platform by releasing the **LATCH** on the back of the control box; take the platform (upper) control box to the ground (lower) control station. Refer to Figure 7-3.

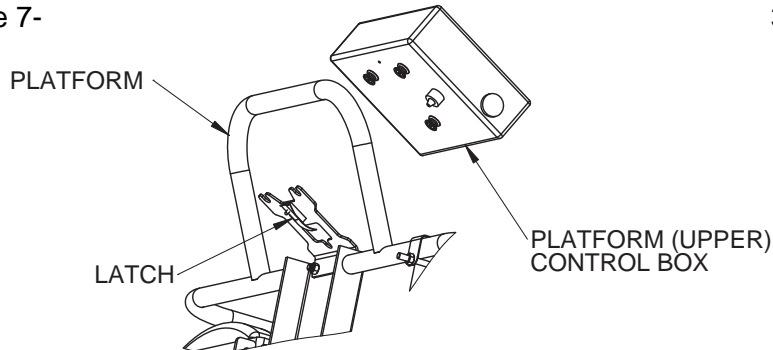

Figure 7-3. Remove Platform (Upper) Control Box.

- Disconnect the electric **LOOPBACK PLUG** from the receptacle on the bottom right of the ground (lower) control box. Refer to Figure 7-4.

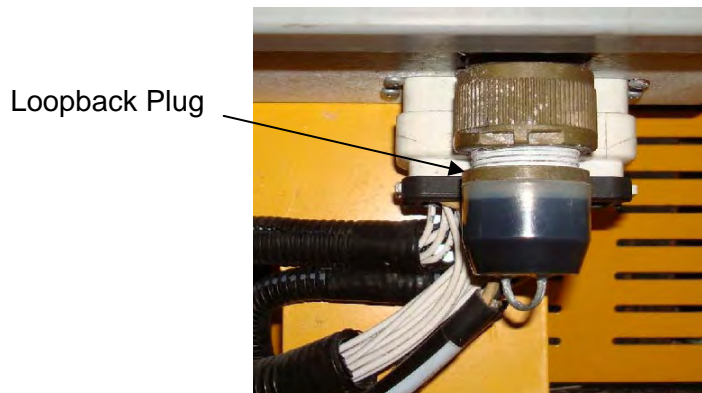

Figure 7-4. Loopback plug

MATERIAL LIFT HOOK (CONTINUED)

- Insert the **PLUG** from the platform (upper) control panel into the receptacle on the bottom right of the ground (lower) control box (replacing the **LOOPBACK PLUG** from the previous step).
- Take the **LOOPBACK PLUG** and insert it into the open receptacle on the **LOAD SENSE MODULE**, located on the **PLATFORM MOUNT**.

NOTE: If the loopback plug is not inserted into the Load Sense, the Emergency Stop circuit will not be complete, and the aerial work platform will not function.

- Firmly secure the platform to prevent equipment damage.
- Remove the **CLEVIS PIN** holding the platform to the **PLATFORM MOUNT**. Refer to Figure 7-5.
- Remove the platform from the **PLATFORM MOUNT** by lifting it up and away from the **PLATFORM MOUNT**.

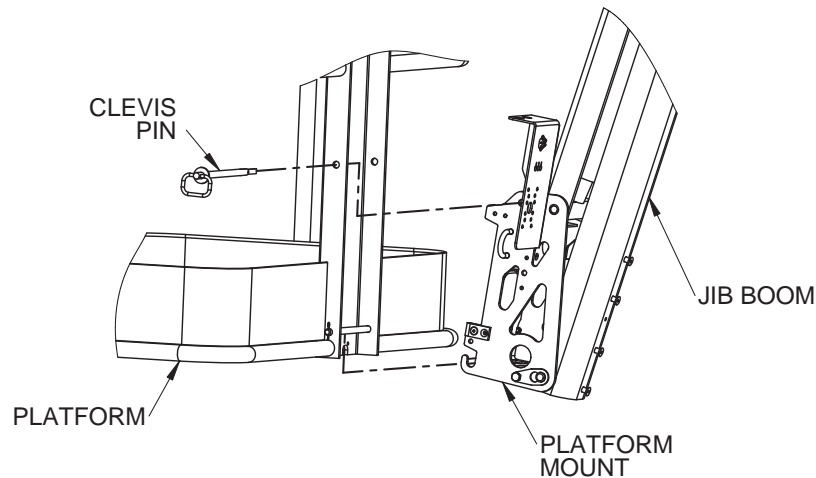

Figure 7-5. Platform Removal

- Attach the material lifting hook to the mounting bracket on the **PLATFORM MOUNT** and re-insert the **CLEVIS PIN**. Refer to Figure 7-6.

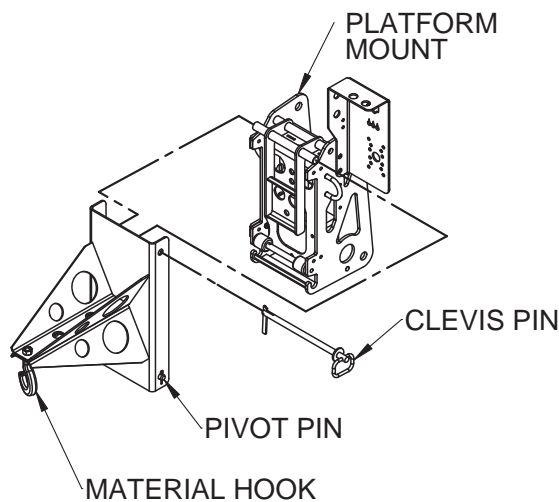

Figure 7-6. Material Lifting Hook Installation

MATERIAL LIFT HOOK (CONTINUED)

- On the ground (lower) control panel, turn the key switch (1) clockwise to the platform control (1b) icon. This provides for optimal control of the lift by using the platform (upper) control panel, and also allows for remote access.
- Reverse this procedure to reattach the Work Platform.

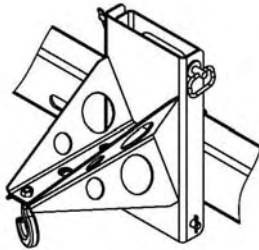

Figure 7-7. Material Lift “Stowed” Position

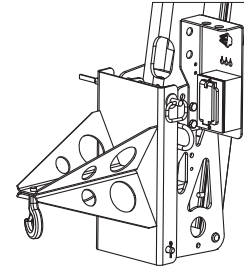

Figure 7-8. Material Lift “In Use” Position

NOTE: To recalibrate the load sense, refer to the “Overload Protection Calibration Procedure” located in the “Equipment Maintenance” section of this manual.

WARNING

ALWAYS observe the manufacturer’s weight lifting limitations when using the material lifting hook. **ALWAYS** use lifting straps or wire rope slings that are rated at a minimum 500 lbs. lifting capacity. **NEVER** stand beneath an elevated load or position an elevated load above personnel. Falling objects could cause death or serious injury.

DANGER

This aerial work platform is not insulated for use near electrical power lines and **DOES NOT** provide protection from contact with or close proximity to any electrically charged conductor. Operator must maintain safe clearances at all times and always allow for platform movement such as wind-induced sway. Refer to Table 1-1 for minimum safe approach distances between the aerial work platform and electrical power lines.

MANUAL PLATFORM ROTATOR

The optional manual platform rotator allows the operator to rotate the elevated work platform 120° around a vertical axis by actuating a rotator handle found below the platform control panel.

Refer to Figure 7-8.

To operate manual platform rotator, turn the rotator handle in the direction of desired rotation (clockwise or counterclockwise). Motion continues in the desired direction until rotator handle is released or the platform reaches a safe travel limit.

WARNING

Installation of a Manual Platform Rotator may reduce the rated load limit of the work platform. Follow all manufacturer's recommendations and safety precautions when operating an aerial work platform equipped with manual platform rotation.

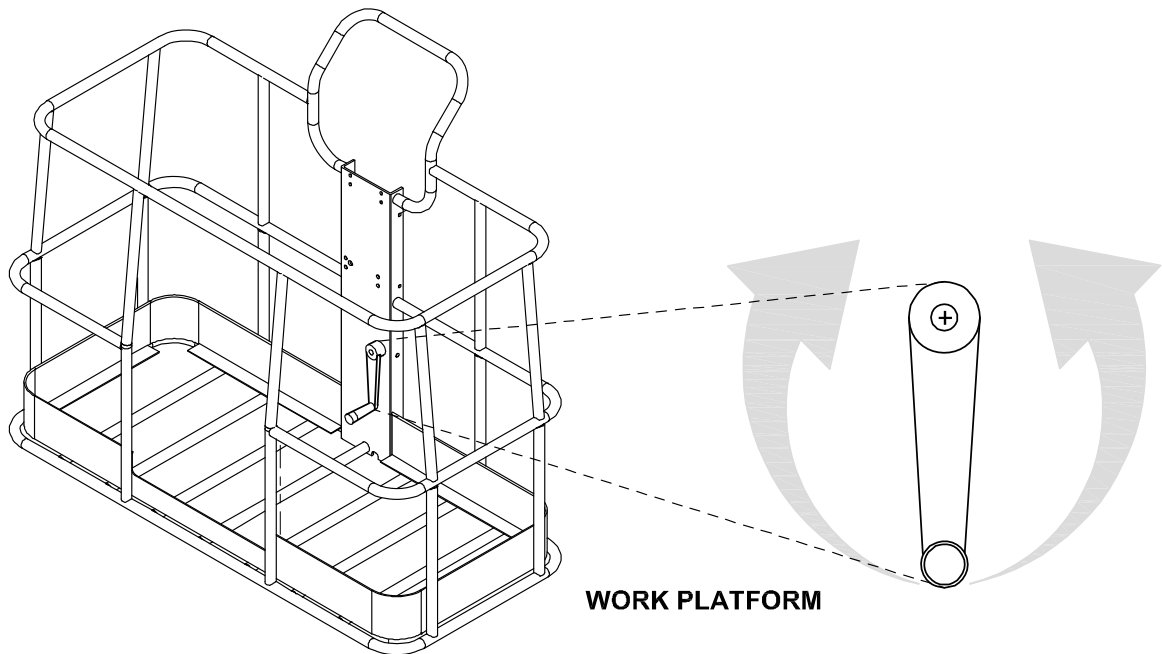

Figure 7-9. Manual Platform Rotator

8 MATERIAL SAFETY

The following Material Safety Data Sheets describe the correct procedures for the safe handling of chemical components within the Model 4527A HTA / 16 P Telescoping Boom Lift, as well as any potential health and safety hazards related to these chemicals. Material Safety Data Sheets are included here in accordance with all Federal State and Local codes and regulations. Read and observe all safety precautions. Maintain awareness of potential health and safety hazards.

MATERIAL SAFETY DATA SHEET FOR LEAD ACID BATTERIES, WET, FILLED WITH ACID

SECTION I – GENERAL INFORMATION					
Manufacturer's Name:	Crown Battery Mfg. Company	EMERGENCY NO: 800 487-2879			
Street Address:	1445 Majestic Drive	OR 800 OIL-TANK			
City, State, Zip	Fremont, Ohio 43420	REVISION DATE: 5/18/2000			
Phone Number:	419 334-7181				
SECTION II -- MATERIAL IDENTIFICATION AND INFORMATION					
COMPONENTS	PERCENT	OSHA PEL	ACGIH TLV	OTHER LIMITS	CAS NUMBER
Hazardous Components 1% or greater Carcinogens 0.01% or greater					
METALLIC LEAD METAL	25.5%	0.05 mg/m3	0.05 mg/m3	NONE	7439-92-1
LEAD SULFATES	18.2%	0.05 mg/m3	0.05 mg/m3	NONE	7439-92-1
LEAD OXIDES	18.0%	0.05 mg/m3	0.05 mg/m3	NONE	7439-92-1
POLYPROPYLENE CASE MTL	6.4%				
SEPARATORS	3.5%				
SULFURIC ACID (H2SO4)	5.2%	1.0 mg/m3	1.0 mg/m3	NONE	7664-93-9
WATER	19.2%				
REGULATORY INFORMATION: Those ingredients listed above are not subject to the reporting requirements of 313 of Title III of the Superfund Amendments and Reauthorization Act. The items are covered in an exemption as a "Manufactured Article". 372.30(b)					
SECTION III -- PHYSICAL / CHEMICAL CHARACTERISTICS					
Boiling Point	Approximately 203F	Vapor Density:	Greater Than 1		
Vapor Pressure	14 @ 37% @ 80 F	Melting Point:	-36 F to -10.6 F		
Solubility in Water	100%	Water Reactive:	Yes, Produces Heat		
Specific Gravity	1.245 - 1.295 Battery Electrolyte				
Appearance & Odor	Clear Liquid with Sharp Pungent Odor				
SECTION IV -- FIRE AND EXPLOSION HAZARD DATA					
Flash Point: Not Combustible					
Auto Ignition Temperature N/A		Flammability Limits in Air % by Volume:		N/A	
Extinguishing Media: Dry Chemical Carbon Dioxide, Water Fog, Water					
<u>Special Fire Fighting Procedures:</u> Sulfuric Acid Fumes, Sulfur Dioxide Gas or Carbon Monoxide may be released when acid decomposes. Wear NIOSH approved self-contained breathing apparatus.					
<u>Unusual Hazards:</u> Water applied to sulfuric acid generates heat and causes acid to splatter. Wear full-cover acid resistant clothing. Sulfuric acid reacts violently with metals, nitrates, chlorates, carbides, fulminates, picrates and other organic materials. Reacts with most metals to yield explosive/flammable hydrogen gas. This reaction is intensified when sulfuric acid is diluted with water to form battery electrolyte.					

MATERIAL SAFETY DATA SHEET

FOR LEAD ACID BATTERIES, WET, FILLED WITH ACID (CONTINUED)

SECTION V -- HEALTH HAZARD DATA

Primary Routes of Entry:	Inhalation: YES Skin: YES Ingestion: YES
Health Hazards:	Acute EYES, SKIN, RESPIRATORY SYSTEM & DIGESTIVE SYSTEM Chronic: EYES, SKIN, RESPIRATORY SYSTEM & DIGESTIVE SYSTEM
Signs and Symptoms of Exposure:	IRRITATION OF EXPOSED AREA, BURNS AND RESPIRATORY PROBLEMS NO POSSIBILITY OF EXPOSURE OF LEAD WILL OCCUR UNLESS BATTERY IS DESTROYED.
Medical Conditions Generally Aggravated By Exposure:	EXPOSURE TO MIST MAY CAUSE LUNG DAMAGE & AGGRAVATE PULMONARY CONDITION.
Emergency First Aid Procedures:	SEEK MEDICAL ASSISTANCE FOR FURTHER TREATMENT, OBSERVATION AND SUPPORT IF NECESSARY.
Eye Contact:	WASH WITH COPIOUS QUANTITIES OF COOL WATER FOR AT LEAST 15 MINUTES
Skin Contact:	FLUSH AREA WITH LARGE AMOUNTS OF COOL WATER FOR AT LEAST 15 MINUTES
Inhalation:	REMOVE TO FRESH AIR, IF BREATHING IS DIFFICULT - GIVE OXYGEN
Ingestion:	GIVE MILK TO DRINK, <u>DO NOT</u> INDUCE VOMITING. CALL PHYSICIAN

SECTION VI -- REACTIVITY DATA

Stability:	STABLE	Conditions to Avoid: N/A
Incompatibility:	AVOID COMBUSTIBLES, ORGANIC MATERIALS, AND STRONG REDUCING AGENTS	
Hazardous Decomposition Products:	SULFUR TRIOXIDE, CARBON MONOXIDE, SULFURIC ACID FUMES, & SULFUR DIOXIDE	
Hazardous Polymerization:	MAY OCCUR	Conditions to Avoid: N/A

SECTION VII -- SPILL OR LEAK PROCEDURES

Steps to be taken in case material is released or spilled:
CONTAIN SPILL, USING NON-COMBUSTIBLE MATERIALS: VERMICULITE, DRY SAND & EARTH. NEUTRALIZE WITH LIME, SODA ASH, SODIUM BICARBONATE, ETC.

Waste disposal method: CONSULT STATE ENVIRONMENTAL AGENCY. INDIVIDUAL STATE REGULATIONS VARY

Precautions to be taken in Handling & Storage: SEPARATE FROM INCOMPATIBLE MATERIALS, KEEP AWAY FROM FIRE, SPARKS AND HEAT

Other Precautions and/or Special Hazards:
CONTACT WITH METALS MAY PRODUCE TOXIC SULFUR DIOXIDE FUMES & MAY ALSO RELEASE FLAMMABLE HYDROGEN GAS. THIS REACTION IS INTENSIFIED WHEN DILUTED.

NFPA Rating:	HEALTH: 3	FLAMMABILITY: 0	REACTIVITY: 2	SPECIAL: 0
HMIS Rating:	HEALTH: 3	FLAMMABILITY: 0	REACTIVITY: 2	PERSONAL PROTECTION: X

SECTION VIII -- CONTROL AND PROTECTIVE MEASURES

Respiratory Protection:	ABOVE P.E.L.: NIOSH APPROVED, FITTED, FULL FACE RESPIRATOR
Protective Gloves:	ACID RESISTANT
Eye Protection:	FULL FACE PROTECTION
Ventilation:	LOCAL EXHAUST: VENTILATED AREA PREFERRED MECHANICAL: IF BELOW P.E.L. SPECIAL: MUST BE ACID & EXPLOSIVE RESISTANT OTHER: MUST BE ACID & EXPLOSIVE RESISTANT
Other Protective Equipment:	ACID RESISTANT CLOTHING AND BOOTS
Hygienic Work Practices:	N/A

MATERIAL SAFETY DATA SHEET

POWERFLOW™ AW HVI HYDRAULIC OIL



Powerflow™ AW HVI Hydraulic Oil (All Grades)

Material Safety Data Sheet

1. Product and Company Identification

Product Name:	Powerflow™ AW HVI Hydraulic Oil (All Grades)
MSDS Number:	814636
Synonyms:	Powerflow™ AW HVI Hydraulic Oil 32 Powerflow™ AW HVI Hydraulic Oil 46 Powerflow™ AW HVI Hydraulic Oil 68
Intended Use:	Hydraulic Fluid
Manufacturer/Supplier:	ConocoPhillips Lubricants 600 N. Dairy Ashford, 2W900 Houston, Texas 77079-1175
Emergency Health and Safety Number:	Chemtrec: 800-424-9300 (24 Hours)
Customer Service:	U.S.: 800-822-6457 or International: +1-83-2486-3363
Technical Information:	800-766-0050
MSDS Information:	Internet: http://w3.conocophillips.com/NetMSDS/

2. Hazards Identification

Emergency Overview

This material is not considered hazardous according to OSHA criteria.

NFPA



Appearance: Clear and bright

Physical Form: Liquid

Odor: Petroleum

Potential Health Effects

Eye: Contact may cause mild eye irritation including stinging, watering, and redness.

Skin: Contact may cause mild skin irritation including redness and a burning sensation. Prolonged or repeated contact can defat the skin, causing drying and cracking of the skin, and possibly dermatitis (inflammation). No harmful effects from skin absorption are expected.

Inhalation (Breathing): No information available on acute toxicity.

Ingestion (Swallowing): Low degree of toxicity by ingestion.

Signs and Symptoms: Effects of overexposure may include irritation of the digestive tract, nausea and diarrhea. Inhalation of oil mist or vapors at elevated temperatures may cause respiratory irritation.

Pre-Existing Medical Conditions: Conditions which may be aggravated by exposure include skin disorders.

See Section 11 for additional Toxicity Information.

814636 - Powerflow™ AW HVI Hydraulic Oil (All Grades)

Date of Issue:

Page 1/7

Status: Final

MATERIAL SAFETY DATA SHEET

POWERFLOW™ AW HVI HYDRAULIC OIL (CONTINUED)

814636 - Powerflow™ AW HVI Hydraulic Oil (All Grades)
Date of Issue: 14-Nov-2008

Page 277
Status: Final

3. Composition / Information on Ingredients

Component	CASRN	Concentration*
Lubricant Base Oil (Petroleum)	VARIOUS	>90
Additives	PROPRIETARY	<10

* All concentrations are percent by weight unless ingredient is a gas. Gas concentrations are in percent by volume.

4. First Aid Measures

Eye Contact: If irritation or redness develops from exposure, flush eyes with clean water. If symptoms persist, seek medical attention.

Skin Contact: Remove contaminated shoes and clothing and cleanse affected area(s) thoroughly by washing with mild soap and water or a waterless hand cleaner. If irritation or redness develops and persists, seek medical attention.

Inhalation (Breathing): If respiratory symptoms develop, move victim away from source of exposure and into fresh air in a position comfortable for breathing. If symptoms persist, seek medical attention.

Ingestion (Swallowing): First aid is not normally required; however, if swallowed and symptoms develop, seek medical attention.

Notes to Physician: High-pressure hydrocarbon injection injuries may produce substantial necrosis of underlying tissue despite an innocuous appearing external wound. These injuries often require extensive emergency surgical debridement and all injuries should be evaluated by a specialist in order to assess the extent of injury. Early surgical treatment within the first few hours may significantly reduce the ultimate extent of injury.

Acute aspirations of large amounts of oil-laden material may produce a serious aspiration pneumonia. Patients who aspirate these oils should be followed for the development of long-term sequelae. Inhalation exposure to oil mists below current workplace exposure limits is unlikely to cause pulmonary abnormalities.

5. Fire-Fighting Measures

NFPA 704 Hazard Class

Health: 0 Flammability: 1 Instability: 0 (0-Minimal, 1-Slight, 2-Moderate, 3-Serious, 4-Severe)

Unusual Fire & Explosion Hazards: This material may burn, but will not ignite readily. If container is not properly cooled, it can rupture in the heat of a fire.

Extinguishing Media: Dry chemical, carbon dioxide, foam, or water spray is recommended. Water or foam may cause frothing of materials heated above 212°F. Carbon dioxide can displace oxygen. Use caution when applying carbon dioxide in confined spaces.

Fire Fighting Instructions: For fires beyond the initial stage, emergency responders in the immediate hazard area should wear protective clothing. When the potential chemical hazard is unknown, in enclosed or confined spaces, a self contained breathing apparatus should be worn. In addition, wear other appropriate protective equipment as conditions warrant (see Section 8).

Isolate immediate hazard area and keep unauthorized personnel out. Stop spill/release if it can be done safely. Move undamaged containers from immediate hazard area if it can be done safely. Water spray may be useful in minimizing or dispersing vapors and to protect personnel. Cool equipment exposed to fire with water, if it can be done safely. Avoid spreading burning liquid with water used for cooling purposes.

Hazardous Combustion Products: Combustion may yield smoke, carbon monoxide, and other products of incomplete combustion. Oxides of sulfur, nitrogen or phosphorus may also be formed.

See Section 9 for Flammable Properties including Flash Point and Flammable (Explosive) Limits

6. Accidental Release Measures

MATERIAL SAFETY DATA SHEET

POWERFLOW™ AW HVI HYDRAULIC OIL (CONTINUED)

814636 - Powerflow™ AW HVI Hydraulic Oil (All Grades)
Date of Issue: 14-Nov-2008

Page 3/7
Status: Final

6. Accidental Release Measures

Personal Precautions: This material may burn, but will not ignite readily. Keep all sources of ignition away from spill/release. The use of explosion-proof electrical equipment is recommended. Stay upwind and away from spill/release. Notify persons down wind of the spill/release, isolate immediate hazard area and keep unauthorized personnel out. Wear appropriate protective equipment, including respiratory protection, as conditions warrant (see Section 8). See Sections 2 and 7 for additional information on hazards and precautionary measures.

Environmental Precautions: Stop spill/release if it can be done safely. Prevent spilled material from entering sewers, storm drains, other unauthorized drainage systems, and natural waterways. Use water sparingly to minimize environmental contamination and reduce disposal requirements. Spills into or upon navigable waters, the contiguous zone, or adjoining shorelines that cause a sheen or discoloration on the surface of the water, may require notification of the National Response Center (phone number 800-424-8802).

Methods for Containment and Clean-Up: Notify relevant authorities in accordance with all applicable regulations. Immediate cleanup of any spill is recommended. Dike far ahead of spill for later recovery or disposal. Absorb spill with inert material such as sand or vermiculite, and place in suitable container for disposal.

7. Handling and Storage

Precautions for safe handling: Wash thoroughly after handling. Use good personal hygiene practices and wear appropriate personal protective equipment.

High pressure injection of hydrocarbon fuels, hydraulic oils or greases under the skin may have serious consequences even though no symptoms or injury may be apparent. This can happen accidentally when using high pressure equipment such as high pressure grease guns, fuel injection apparatus or from pinhole leaks in tubing of high pressure hydraulic oil equipment.

Do not enter confined spaces such as tanks or pits without following proper entry procedures such as ASTM D-4276 and 29CFR 1910.146. Do not wear contaminated clothing or shoes.

"Empty" containers retain residue and may be dangerous. Do not pressurize, cut, weld, braze, solder, drill, grind, or expose such containers to heat, flame, sparks, or other sources of ignition. They may explode and cause injury or death. "Empty" drums should be completely drained, properly bunged, and promptly shipped to the supplier or a drum reconditioner. All containers should be disposed of in an environmentally safe manner and in accordance with governmental regulations. Before working on or in tanks which contain or have contained this material, refer to OSHA regulations, ANSI Z49.1, and other references pertaining to cleaning, repairing, welding, or other contemplated operations.

Conditions for safe storage: Use and store this material in cool, dry, well-ventilated area away from heat and all sources of ignition. Keep container(s) tightly closed. Store only in approved containers. Keep away from any incompatible material (see Section 10). Protect container(s) against physical damage.

8. Exposure Controls / Personal Protection

Component	US-ACGIH	OSHA	Other
Lubricant Base Oil (Petroleum)	TWA: 5mg/m ³ STEL: 10 mg/m ³ as Oil Mist, if generated	TWA: 5 mg/m ³ as Oil Mist, if generated	---

Note: State, local or other agencies or advisory groups may have established more stringent limits. Consult an industrial hygienist or similar professional, or your local agencies, for further information.

Engineering controls: If current ventilation practices are not adequate to maintain airborne concentrations below the established exposure limits, additional engineering controls may be required.

Eye/Face Protection: The use of eye protection that meets or exceeds ANSI Z.87.1 is recommended to protect against potential eye contact, irritation, or injury. Depending on conditions of use, a face shield may be necessary.

Skin/Hand Protection: The use of gloves impervious to the specific material handled is advised to prevent skin contact. Users should check with manufacturers to confirm the breakthrough performance of their products. Suggested protective materials: Nitrile.

MATERIAL SAFETY DATA SHEET

POWERFLOW™ AW HVI HYDRAULIC OIL (CONTINUED)

814636 - Powerflow™ AW HVI Hydraulic Oil (All Grades)
Date of Issue: 14-Nov-2008

Page 4/7
Status: Final

Respiratory Protection: Where there is potential for airborne exposure above the exposure limit a NIOSH certified air purifying respirator equipped with R or P95 filters may be used.

A respiratory protection program that meets or is equivalent to OSHA 29 CFR 1910.134 and ANSI Z88.2 should be followed whenever workplace conditions warrant a respirator's use. Air purifying respirators provide limited protection and cannot be used in atmospheres that exceed the maximum use concentration (as directed by regulation or the manufacturer's instructions), in oxygen deficient (less than 19.5 percent oxygen) situations, or under conditions that are immediately dangerous to life and health (IDLH).

Suggestions provided in this section for exposure control and specific types of protective equipment are based on readily available information. Users should consult with the specific manufacturer to confirm the performance of their protective equipment. Specific situations may require consultation with industrial hygiene, safety, or engineering professionals.

9. Physical and Chemical Properties

Note: Unless otherwise stated, values are determined at 20°C (68°F) and 760 mm Hg (1 atm). Data represent typical values and are not intended to be specifications.

Appearance:	Clear and bright
Physical Form:	Liquid
Odor:	Petroleum
Odor Threshold:	No data
pH:	Not applicable
Vapor Pressure:	<1 mm Hg
Vapor Density (air=1):	>1
Boiling Point/Range:	No data
Melting/Freezing Point:	<-29.2°F / <-34°C
Pour Point:	<-29.2°F / <-34°C
Solubility in Water:	Insoluble
Partition Coefficient (n-octanol/water) (Kow):	No data
Specific Gravity:	0.87 @ 60°F (15.6°C)
Bulk Density:	7.3 lbs/gal
Viscosity:	7 - 12 cSt @ 100°C; 32 - 68 cSt @ 40°C
Evaporation Rate (nBuAc=1):	No data
Flash Point:	>320°F / >160°C
Test Method:	Pensky-Martens Closed Cup (PMCC), ASTM D93, EPA 1010
LEL (vol % in air):	No data
UEL (vol % in air):	No data
Autoignition Temperature:	No data

10. Stability and Reactivity

Stability: Stable under normal ambient and anticipated conditions of use.

Conditions to Avoid: Extended exposure to high temperatures can cause decomposition.

Materials to Avoid (Incompatible Materials): Avoid contact with strong oxidizing agents and strong reducing agents.

Hazardous Decomposition Products: Not anticipated under normal conditions of use.

Hazardous Polymerization: Not known to occur.

MATERIAL SAFETY DATA SHEET

POWERFLOW™ AW HVI HYDRAULIC OIL (CONTINUED)

814636 - Powerflow™ AW HVI Hydraulic Oil (All Grades)
Date of Issue: 14-Nov-2008

Page 5/7
Status: Final

11. Toxicological Information

Chronic Data:

Lubricant Base Oil (Petroleum)

Carcinogenicity: The petroleum base oils contained in this product have been highly refined by a variety of processes including severe hydrocracking/hydroprocessing to reduce aromatics and improve performance characteristics. All of the oils meet the IP-346 criteria of less than 3 percent PAH's and are not considered carcinogens by NTP, IARC, or OSHA.

Acute Data:

Component	Oral LD50	Dermal LD50	Inhalation LC50
Lubricant Base Oil (Petroleum)	>5 g/kg	>2 g/kg	No data

12. Ecological Information

Ecotoxicity: Experimental studies show that acute aquatic toxicity values are greater than 1000 mg/l. These values are consistent with the predicted aquatic toxicity of these substances based on their hydrocarbon compositions.

Mobility: Volatilization to air is not expected to be a significant fate process due to the low vapor pressure of this material. In water, base oils will float and spread over the surface at a rate dependent upon viscosity. There will be significant removal of hydrocarbons from the water by sediment adsorption. In soil and sediment, hydrocarbon components will show low mobility with adsorption to sediments being the predominant physical process. The main fate process is expected to be slow biodegradation of base oil components in soil and sediment.

Persistence and degradability: The hydrocarbons in this material are not readily biodegradable, but since they can be degraded by microorganisms, they are regarded as inherently biodegradable.

Bioaccumulation Potential: Log Kow values measured for the hydrocarbon components of this material range from 4 to over 6, and therefore regarded as having the potential to bioaccumulate. In practice, metabolic processes may reduce bioconcentration.

13. Disposal Considerations

The generator of a waste is always responsible for making proper hazardous waste determinations and needs to consider state and local requirements in addition to federal regulations.

This material, if discarded as produced, would not be a federally regulated RCRA "listed" hazardous waste and is not believed to exhibit characteristics of hazardous waste. See Sections 7 and 8 for information on handling, storage and personal protection and Section 9 for physical/chemical properties. It is possible that the material as produced contains constituents which are not required to be listed in the MSDS but could affect the hazardous waste determination. Additionally, use which results in chemical or physical change of this material could subject it to regulation as a hazardous waste.

This material under most intended uses would become "Used Oil" due to contamination by physical or chemical impurities. Whenever possible, Recycle Used Oil in accordance with applicable federal and state or local regulations. Container contents should be completely used and containers should be emptied prior to discard.

14. Transportation Information

U.S. Department of Transportation (DOT)

Shipping Description: *Not regulated*
Note: *If shipped by land in a packaging having a capacity of 3,500 gallons or more, the provisions of 49 CFR, Part 130 apply. (Contains oil)*

International Maritime Dangerous Goods (IMDG)

Shipping Description: *Not regulated*
Note: *U.S. DOT compliance requirements may apply. See 49 CFR 171.22, 23 & 25.*

International Civil Aviation Org. / International Air Transport Assoc. (ICAO/IATA)

UN/ID #: *Not regulated*

MATERIAL SAFETY DATA SHEET

POWERFLOW™ AW HVI HYDRAULIC OIL (CONTINUED)

814636 - Powerflow™ AW HVI Hydraulic Oil (All Grades)
Date of Issue: 14-Nov-2008

Page 6/7
Status: **Final**

14. Transportation Information

	LTD. QTY	Passenger Aircraft	Cargo Aircraft Only
Packaging Instruction #:	---	---	---
Max. Net Qty. Per Package:	---	---	---

15. Regulatory Information

CERCLA/SARA - Section 302 Extremely Hazardous Substances and TPQs (in pounds):

This material does not contain any chemicals subject to the reporting requirements of SARA 302 and 40 CFR 372.

CERCLA/SARA - Section 311/312 (Title III Hazard Categories)

Acute Health:	No
Chronic Health:	No
Fire Hazard:	No
Pressure Hazard:	No
Reactive Hazard:	No

CERCLA/SARA - Section 313 and 40 CFR 372:

This material contains the following chemicals subject to the reporting requirements of Section 313 of SARA Title III and 40 CFR 372:

Component	Concentration*	de minimis
Zinc Compound(s)	1	1.0%

EPA (CERCLA) Reportable Quantity (in pounds):

This material does not contain any chemicals with CERCLA Reportable Quantities.

California Proposition 65:

This material does not contain any chemicals which are known to the State of California to cause cancer, birth defects or other reproductive harm at concentrations that trigger the warning requirements of California Proposition 65.

Canadian Regulations:

This product has been classified in accordance with the hazard criteria of the Controlled Products Regulations (CPR) and the MSDS contains all the information required by the Regulations.

WHMIS Hazard Class
None

National Chemical Inventories:

All components are either listed on the US TSCA Inventory, or are not regulated under TSCA.
All components are either on the DSL, or are exempt from DSL listing requirements.

U.S. Export Control Classification Number: EAR99

16. Other Information

Date of Issue: 14-Nov-2008
Status: **Final**
Revised Sections or Basis for Revision: New MSDS
MSDS Number: 814636

Guide to Abbreviations:

ACGIH = American Conference of Governmental Industrial Hygienists; CASRN = Chemical Abstracts Service Registry Number; CEILING = Ceiling Limit (15 minutes); CERCLA = The Comprehensive Environmental Response, Compensation, and Liability Act; EPA = Environmental Protection Agency; IARC = International Agency for Research on Cancer; LEL = Lower Explosive Limit; NE = Not Established; NFPA = National Fire Protection Association; NTP = National Toxicology Program; OSHA = Occupational Safety and Health Administration; PEL = Permissible Exposure Limit (OSHA); SARA = Superfund Amendments and Reauthorization Act; STEL = Short Term Exposure Limit (15 minutes); TLV = Threshold Limit Value (ACGIH); TWA = Time Weighted Average (8 hours); UEL = Upper Explosive Limit; WHMIS = Worker Hazardous Materials Information System (Canada)

MATERIAL SAFETY DATA SHEET

POWERFLOW™ AW HVI HYDRAULIC OIL (CONTINUED)

814636 - Powerflow™ AW HVI Hydraulic Oil (All Grades)

Date of Issue: 14-Nov-2008

Page 7/7

Status: Final

Disclaimer of Expressed and implied Warranties:

The information presented in this Material Safety Data Sheet is based on data believed to be accurate as of the date this Material Safety Data Sheet was prepared. HOWEVER, NO WARRANTY OF MERCHANTABILITY, FITNESS FOR ANY PARTICULAR PURPOSE, OR ANY OTHER WARRANTY IS EXPRESSED OR IS TO BE IMPLIED REGARDING THE ACCURACY OR COMPLETENESS OF THE INFORMATION PROVIDED ABOVE, THE RESULTS TO BE OBTAINED FROM THE USE OF THIS INFORMATION OR THE PRODUCT, THE SAFETY OF THIS PRODUCT, OR THE HAZARDS RELATED TO ITS USE. No responsibility is assumed for any damage or injury resulting from abnormal use or from any failure to adhere to recommended practices. The information provided above, and the product, are furnished on the condition that the person receiving them shall make their own determination as to the suitability of the product for their particular purpose and on the condition that they assume the risk of their use. In addition, no authorization is given nor implied to practice any patented invention without a license.

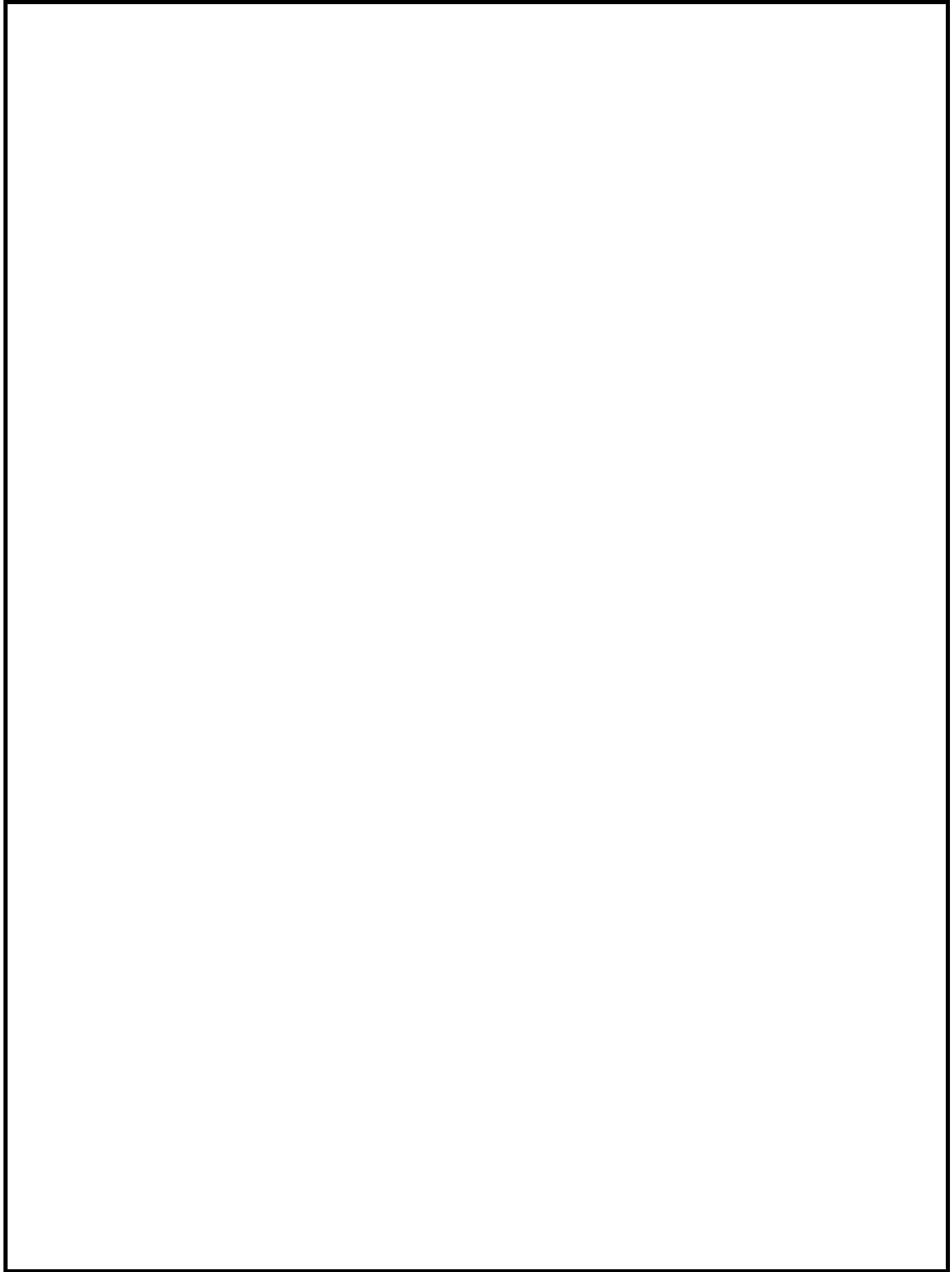

9 AXLE AND RELATED COMPONENTS

If you have a North American - ANSI aerial lift platform refer to section **9A** Dexter Axle and Related Components.

If you have a European - CE aerial lift platform refer to section **9B** Bradley Brake Adjustment section.

9A DEXTER AXLE AND RELATED COMPONENTS

The following sections are reprinted from the Dexter Axle Operation and Maintenance Manual 2008.

SET UP AND ADJUSTMENT

For proper performance, all new axles should have the following checked at the specified intervals:

- **Wheel Nut Torque:** at 10, 25, and 50 miles (16, 40, and 80 Kilometers).
- **Brake Adjustment:** at 200 and 3,000 miles (322, and 4,828 Kilometers).
- **Tire Pressure:** to manufacturer's requirements.
- **Brake Synchronization:** set brake controller per controller manufacturer's directions.

GENERAL MAINTENANCE – ELECTRIC BRAKES

Drum Brake Adjustment

Most Dexter 12 1/4" electric brakes have a self adjusting feature. If manual adjusting is required, use the following procedure:

Brakes should be adjusted (1) after the first 200 miles (322 Kilometers), of operation when the brake shoes and drums have "seated", (2) at 3,000 mile (4,828 Kilometers) intervals, (3) or as use and performance requires. The brakes should be adjusted in the following manner:

1. Jack up trailer and secure on adequate capacity jack stands. Follow trailer manufacturer's recommendations for lifting and supporting the unit. Make sure the wheel and drum rotates freely.



CAUTION

DO NOT lift or support the trailer on any part of the axle or suspension system. NEVER go under any trailer unless it is properly supported on jack stands which have been rated for the load. Improperly supported vehicles can fall unexpectedly and cause serious injury or death.

2. Remove the adjusting hole cover from the adjusting slot on the bottom of the brake backing plate.
3. With a screwdriver or standard adjusting tool, rotate the star wheel of the adjuster assembly to expand the brake shoes. Adjust the brake shoes out until the pressure of the linings against the drum makes the wheel very difficult to turn.

NOTE: For drop spindle axles, a modified adjusting tool may be necessary.

4. Then rotate the star wheel in the opposite direction until the wheel turns freely with a slight lining drag.
5. Replace the adjusting hole cover and lower the wheel to the ground.
6. Repeat the above procedure on all brakes. For best results, the brakes should be set at the same clearance.

SET UP AND ADJUSTMENT (CONTINUED)

GENERAL MAINTENANCE – HYDRAULIC BRAKES

Drum Brake Adjustment - Manual

Most Dexter 12 1/4" hydraulic brakes have a self adjusting feature. If manual adjusting is required, use the following procedure:

Brakes should be adjusted (1) after the first 200 miles (322 Kilometers), of operation when the brake shoes and drums have "seated", (2) at 3,000 mile (4,828 Kilometers) intervals, (3) or as use and performance requires. The brakes should be adjusted in the following manner:

1. Jack up trailer and secure on adequate capacity jack stands. Follow trailer manufacturer's recommendations for lifting and supporting the unit. Make sure the wheel and drum rotates freely.



CAUTION

DO NOT lift or support the trailer on any part of the axle or suspension system. NEVER go under any trailer unless it is properly supported on jack stands which have been rated for the load. Improperly supported vehicles can fall unexpectedly and cause serious injury or death.

2. Remove the adjusting hole cover from the adjusting slot on the bottom of the brake backing plate.
3. With a screwdriver or standard adjusting tool, rotate the star wheel of the adjuster assembly to expand the brake shoes. Adjust the brake shoes out until the pressure of the linings against the drum makes the wheel very difficult to turn.

NOTE: For drop spindle axles, a modified adjusting tool may be necessary.

4. Then rotate the star wheel in the opposite direction until the wheel turns freely with a slight lining drag.
5. Replace the adjusting hole cover and lower the wheel to the ground.
6. Repeat the above procedure on all brakes. For best results, the brakes should be set at the same clearance.

Synchronizing Your Trailer Brakes

To insure safe brake performance and synchronization, read the brake controller manufacturer's instructions completely before attempting any synchronization procedure.



CAUTION

Before road testing, make sure the area is clear of vehicular and pedestrian traffic. Failure to brake safely could result in an accident and personal injury to your self and / or others.

Make several hard stops from 20 mph (32 Km/hr) on a dry paved road free of sand and gravel. If the trailer brakes lock and slide, decrease the gain setting on the controller. If they do not slide, slightly increase the gain setting. Adjust the controller just to the point of impending brake lockup and wheel skid.

SET UP AND ADJUSTMENT (CONTINUED)

NOTE: Not all trailer brakes are capable of wheel lockup. Loading conditions, brake type, wheel and tire size can all affect whether a brake can lock. It is not generally considered desirable to lock up the brakes and slide the tires. This can cause unwanted flat spotting of the tires and could also result in a loss of control.

If the controller is applying the trailer brakes before the tow vehicle brakes, then the controller adjustment should be made so the trailer brakes come on in synchronization with the tow vehicle brakes. For proper braking performance, it is recommended that the controller be adjusted to allow the trailer brakes to come on just slightly ahead of the tow vehicle brakes. When proper synchronization is achieved there will be no sensation of the trailer “Jerking” or “Pushing” the tow vehicle during braking.



CAUTION

DO NOT attempt to repair or modify a damaged wheel. Even minor modifications can cause a dangerous failure of the wheel and result in personal injury or death.

Torque Requirements

In June of 2004, Dexter Axle ceased production of trailer wheels. If your vehicle is equipped with Dexter steel wheels manufactured before that date, the following wheel torque information will be applicable.

If your trailer is equipped with wheels produced by other manufacturers, you must consult with the vehicle manufacturer to determine the appropriate torque lever for your wheels. However, you must not exceed the limits of the wheel mounting studs on the axles.

It is extremely important to apply and maintain proper wheel mounting torque on your trailer axle. Torque is a measure of the amount of tightening applied to a fastener (nut or bolt) and is expressed as length force. For example, a force of 90 pounds (40 kilograms) applied at the end of a wrench one (1) foot (.304 meter) long will yield 90 ft.-lbs (122N-m) of torque. Torque wrenches are the best method to assure the proper amount of torque is being applied to a fastener.



CAUTION

Wheel nuts or bolts must be tightened and maintained at the proper torque levels to prevent loose wheels, broken studs, and possible dangerous separation of wheels from your axle, which can lead to an accident, personal injury or death.

Be sure to use only the fasteners matched to the cone angle of your wheel (usually 60° or 90°). The proper procedure for attaching your wheels is as follows:

1. Start all bolts or nuts by hand to prevent cross threading.
2. Tighten bolts or nuts in the sequence shown for Wheel Torque Requirements.
3. The tightening of the fasteners should be done in stages. Following the recommended sequence, tighten fasteners per wheel torque requirements diagram.

SET UP AND ADJUSTMENT (CONTINUED)

Wheel nuts / bolts should be torqued before the first road use and after each wheel removal. Check and re-torque after the first 10, 25, and 50 miles (16, 40, and 80 kilometers). Check periodically thereafter.

TABLE 9-1. WHEEL TORQUE REQUIREMENTS
(For Dexter Steel Wheels Prior to June of 2004)

TORQUE SEQUENCE			
Wheel Size	1st Stage	2nd Stage	3rd Stage
12"	20-25 ft-lb (27-34 N-m)	35-40 ft-lb (47-54 N-m)	50-75 ft-lb (68-102 N-m)
13"	20-25 ft-lb (27-34 N-m)	35-40 ft-lb (47-54 N-m)	50-75 ft-lb (68-102 N-m)
14"	20-25 ft-lb (27-34 N-m)	50-60 ft-lb (68-81 N-m)	90-120 ft-lb (122-162 N-m)
15"	20-25 ft-lb (27-34 N-m)	50-60 ft-lb (68-81 N-m)	90-120 ft-lb (122-162 N-m)
16"	20-25 ft-lb (27-34 N-m)	50-60 ft-lb (68-81 N-m)	90-120 ft-lb (122-162 N-m)
16.5" x 6.75"	20-25 ft-lb (27-34 N-m)	50-60 ft-lb (68-81 N-m)	90-120 ft-lb (122-162 N-m)
16.5" x 9.75	55-60 ft-lb (75-81 N-m)	120-125 ft-lb (162-169 N-m)	175-225 ft-lb (237-305 N-m)
14.5 Demont	Tighten sequentially to		85-95 ft-lb (115-128 N-m)
17.5" Hub Pilot Clamp Ring & Cone Nuts	50-60 ft-lb (68-81 N-m)	100-120 ft-lb (135-162 N-m)	190-210 ft-lb (257-284 N-m)
17.5" Hub Pilot 5/16" Flange Nuts	50-60 ft-lb (68-81 N-m)	90-200 ft-lb (122-270 N-m)	275-325 ft-lb (372-441 N-m)

Maximum Wheel Fastener Torque

The wheel mounting studs used on Dexter axles conform to the SAE standards for grade 8. The maximum torque level that can be safely applied to these studs is listed in the following chart:

Stud Size	Maximum Torque
1/2"-20 UNF, class 2A	120 ft-lb (162 N-m)
9/16"-18 UNF, class 2A	170 ft-lb (230 N-m)
5/8"-18 UNF, class 2A	325 ft-lb (440 N-m)



CAUTION

Exceeding the above listed torque limits can damage studs and / or nuts and lead to eventual fractures and dangerous wheel separation.

HOW TO USE YOUR ELECTRIC BRAKES PROPERLY

Your trailer brakes are designed to work in synchronization with your tow vehicle brakes. Never use your tow vehicle or trailer brakes alone to stop the combined load.

Your brake controller must be set up according to the manufacturer's recommendations to ensure proper synchronization between the tow vehicle and the trailer. Additionally, you may have to make small adjustments occasionally to accommodate changing loads and driving conditions.

Proper synchronization of tow vehicle to trailer braking can only be accomplished by road testing. Brake lockup, "grabiness", or harshness is quite often due to the lack of synchronization between the tow vehicle and the trailer being towed, too high of a threshold voltage (over 2 volts), or under adjusted brakes.

Before any synchronization adjustments are made, your trailer brakes should be burnished-in by applying the brakes 20-30 times with approximately a 20 mph (32 Km/h) decrease in speed, e.g. 40 mph (64Km/h) to 20 mph (32Km/h). Allow ample time for brakes to cool between applications. This allows the brake shoes and magnets to slightly "wear-in" to the drum surfaces.

TABLE 9-2. TRAILER WIRE SIZE CHART

Number of Brakes	Hitch-to-Axle	Recommended Minimum Hook-up Wire size (copper)
2		12 AWG
4	Under 30 ft (9.0 m)	12 AWG
4	30 ft - 50 ft (9.0 - 15m)	10 AWG
6	Under 30 ft (9.0 m)	10 AWG
6	30 ft - 50 ft (9.0 - 15m)	8 AWG

MAINTENANCE**TABLE 9-3. MAINTENANCE SCHEDULE**

Item	Function Required	Weekly	3 Months or 3,000 Miles (4,828 Km)	6 Months or 6,000 Miles (9,656 Km)	12 Months or 12,000 Miles (19,312 Km)
Brakes	Test That They Are Operational.	At Every Use			
Brake Adjustment	Adjust to Proper Operating Clearance.		•		
Brake Magnets	Inspect For Wear and Current Draw.			•	
Brake Linings	Inspect For Wear or Contamination.				•
Brake Controller	Check for Correct Amperage and Modulation.			•	
Brake Cylinders	Check for Leaks, Sticking.				•
Brake Lines	Inspect for Cracks, Leaks, and Kinks.				•
Trailer Brake Wiring	Inspect Wiring for Bare Spots, Fray, etc.				•
Breakaway System	Check Battery Charge and Switch Operation.	At Every Use			
Hub / Drum	Inspect for Abnormal Wear or Scoring.				•
Wheel Bearings and Cups	Inspect for Corrosion or Wear. Clean and Repack.				•
Seals	Inspect for Leakage. Replace if Removed.				•
Springs	Inspect for Wear, Loss of Arch.				•
Suspension Parts	Inspect for Bending, Loose Fasteners and Wear.			•	
Hangers	Inspect Welds.				•
Wheel Nuts and Bolts	Tighten to Specified Torque Values.		•		
Wheels	Inspect for Cracks, Dents, or Distortion.			•	
Tire Inflation Pressure	Inflate Tires to Manufacturer's Specifications.	•			
Tire Condition	Inspect for Cuts, Wear, Bulging, etc.		•		

MAINTENANCE (CONTINUED)

MAGNETS

Your electric brakes are equipped with high quality electromagnets that are designed to provide the proper input force and friction characteristics. Your magnets should be inspected and replaced if worn unevenly or abnormally. As indicated below, a straightedge should be used to check magnet condition. For best results, the magnet should be flat.

Even if wear is normal as indicated by your straightedge, the magnets should be replaced if any part of the magnet coil has become visible through the friction material facing of the magnet. It is also recommended that the drum armature surface be refaced when replacing magnets (see section on Brake Drum Inspection). Magnets should also be replaced in pairs – both sides of an axle. Use only genuine Dexter replacement parts when replacing your magnets.

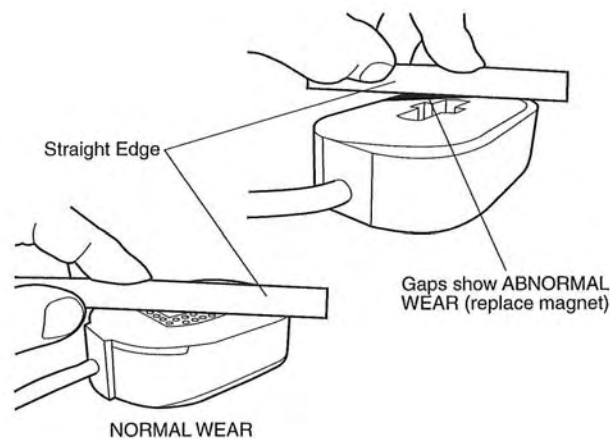

BREAK CLEANING AND INSPECTION

Your trailer brakes must be inspected and serviced immediately if a loss of performance is indicated. With normal use, servicing at one year intervals is usually adequate. With increased usage, this work should be done more frequently as required. Magnets and shoes must be changed when they become excessively worn or scored, a condition which can reduce vehicle braking.

Clean the backing plate, magnet arm, magnet, and brake shoes. Make certain that all the parts removed are replaced in the same brake and drum assembly. Inspect for any loose or worn parts, stretched or deformed springs and replace as necessary.



CAUTION

POTENTIAL ASBESTOS DUST HAZARD!

Some older brake linings may contain asbestos dust, which has been linked to serious or fatal illnesses.

Certain precautions need to be taken when servicing brakes:

1. Avoid creating or breathing dust.
2. Avoid machining, filing or grinding the brake linings.
3. **DO NOT** use compressed air or dry brushing for cleaning (dust can be removed with a damp brush).

MAINTENANCE (CONTINUED)

BRAKE LUBRICATION

Before reassembling, apply a light film of grease or anti-seize compound on the brake anchor pin, the actuation arm bushing and pin, and the areas on the backing plate that are in contact with the brake shoes and magnet lever arm. Apply a light film of grease on the actuation block mounted on the actuation arm.

CAUTION

DO NOT get grease or oil on the brake linings, drums or magnets.

SHOES AND LININGS

A simple visual inspection of your brake linings will tell if they are usable. Replacement is necessary if the lining is worn to 1/16" (.159 cm) or less. Shoes contaminated with grease or oil, or abnormally scored or gouged should also be replaced. Hairline heat cracks are normal in bonded linings and should not be cause for concern. When replacement is necessary, it is important to replace both shoes on each brake and both brakes of the same axle. This will help retain the "balance" or your brakes.



CAUTION

POTENTIAL ASBESTOS DUST HAZARD!

Some older brake linings may contain asbestos dust, which has been linked to serious or fatal illnesses. Certain precautions need to be taken when servicing brakes:

1. **Avoid creating or breathing dust.**
2. **Avoid machining, filing or grinding the brake linings.**
3. **Do not use compressed air or dry brushing for cleaning (dust can be removed with a damp brush).**

After replacement of brake shoes and linings, the brakes must be re-burnished to seat in the new components. This should be done by applying the brakes 20 - 30 times from an initial speed of 40 mph (64 Km/h), slowing the vehicle to 20 mph (32 Km/h). Allow ample time for brakes to cool between applications. This procedure allows the brake shoes to seat in to the drum surface.

HUBS / DRUMS / BEARINGS

Dexter Axle offers several types of bearing arrangements and lubrication methods.

- Dexter's standard wheel bearing configuration consists of opposed tapered roller bearing cones and cups, fitted inside of a precision machined cast hub. This method of using tapered roller bearings requires that a minimal amount of axial end play is essential to the longevity of the bearings service life. This design is typically lubricated with grease, packed into the bearings. Oil lubrication is another method which is available in some of the larger axle capacities.
- E-Z Lube® is another option chosen by some trailer manufacturers. If your axle is equipped with the Dexter E-Z Lube® feature, the bearings can be periodically lubricated without removing the hubs from the axle. This feature consists of axle spindles that have been specially drilled and assembled with grease fittings in their ends. When grease is pumped into the fitting, it is channeled to the inner bearing and then flows back to the outer bearing and eventually back out the grease cap hole.

MAINTENANCE (CONTINUED)

- Nev-R-Lube™ option is the latest innovation from Dexter. Nev-R-Lube™ bearings are comprised of opposed tapered roller bearing cones sealed inside of a precision ground, one piece double cup arrangement. These bearings are designed with a small amount of axial end play. This end play is essential to the longevity of the bearings service life. They are lubricated, assembled and sealed at the factory. No further lubrication is ever needed.

Before attempting any disassembly of your Dexter axle, make sure you read and follow the instructions for the appropriate axle type.

HUB REMOVAL – STANDARD BEARINGS.

Whenever the hub equipment on your axle must be removed for inspection or maintenance the following procedure should be utilized.

1. Elevate and support the trailer unit per manufacturers' instructions.



CAUTION

You must follow the maintenance procedures to prevent damage to important structural components. Damage to certain structural components such as wheel bearings can cause the wheel end to come off of the axle. Loss of a wheel end while the trailer is moving can cause you to lose control and lead to an accident, which can result in serious injury or death.

2. Remove the wheel.
3. Remove the grease cap by carefully prying progressively around the flange of the cap. If the hub is an oil lube type, then the cap can be removed by unscrewing it counterclockwise while holding the hub stationary.
4. Remove the cotter pin from the spindle nut.
For E-Z Lube® axles produced after February of 2002, a new type of retainer is used. Gently pry off retainer from the nut and set aside.
5. Unscrew the spindle nut (counterclockwise) and remove the spindle washer.
6. Remove the hub from the spindle, being careful not to allow the outer bearing cone to fall out. The inner bearing cone will be retained by the seal.
7. For 7,200 lb. (3,265 Kg) and 8,000 lb. (3,628 Kg) axles, a hub puller may be necessary to assist in drum removal.

BRAKE DRUM INSPECTION

There are two areas of the brake drum that are subject to wear and require periodic inspection. These two areas are the drum surface where the brake shoes make contact during stopping and the armature surface where the magnet contacts (only in electric brakes)

The drum surface should be inspected for excessive wear or heavy scoring. If worn more than .020" (.05 cm) oversized, or the drum has worn out of round by more than .015" (.038 cm), then the drum surface should be re-machined. If scoring or other wear is greater than .090" (.228) on the diameter, the drum must be replaced.

MAINTENANCE (CONTINUED)

When turning the drum surface, the maximum rebores diameter is as follows:

- 7" Brake Drum – 7.090" (18.0 cm) diameter
- 10" Brake Drum – 10.090" (25.6 cm) diameter
- 12" Brake Drum – 12.090" (30.7 cm) diameter
- 12 1/4" Brake Drum – 12.340" (31.3 cm) diameter
- 6K and 8K Rotor – 1.03" 2.61 cm) minimum thickness
- 3.5K Rotor – .85" (2.16 cm) minimum thickness

The machined inner surface of the brake drum that contacts the brake magnet is called the armature surface. If the armature surface is scored or worn unevenly, it should be refaced to a 120 micro inch finish by removing not more than .030" (.07 cm) of material. To insure proper contact between the armature face and the magnet face, the magnets should be replaced whenever the armature surface is refaced and the armature surface should be refaced whenever the magnets are replaced.

Note: It is important to protect the wheel bearing bores from metallic chips and contamination which result from drum turning or armature refacing operations. Make certain that the wheel bearing cavities are clean and free of contamination before reinstalling bearing and seals. The presence of these contaminants will cause premature wheel bearing failure.

BEARING INSPECTION

Wash all grease and oil from the bearing cone using a suitable solvent. Dry the bearing with a clean, lint-free cloth and inspect each roller completely.



Be sure to wear safety glasses when removing or installing force fitted parts. Failure to comply may result in serious eye injury.

If any pitting, spalling, or corrosion is present, then the bearing must be replaced. The bearing cup inside the hub must be inspected.

IMPORTANT: Bearings must always be replaced in sets of a cone and a cup.

CAUTION

NEVER spin the bearing with compressed air.
THIS CAN DAMAGE THE BEARING.

When replacing the bearing cup proceed as follows:

- 1 Place the hub on a flat work surface with the cup to be replaced on the bottom side.
- 2 Using a brass drift punch, carefully tap around the small diameter end of the cup to drive out.
- 3 After cleaning the hub bore area, replace the cup by tapping in with the brass drift punch. Be sure the cup is seated all the way against the retaining shoulder in the hub.

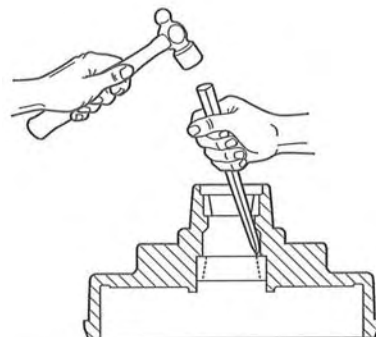

Replace only with bearings as specified in the Bearing Replacement Chart.

MAINTENANCE (CONTINUED)

BEARING LUBRICATION – GREASE

CAUTION

DO NOT mix Lithium, calcium, sodium or barium complex greases due to possible compatibility problems.

When changing from one type of grease to another, it is necessary to insure all the old grease has been removed.

Along with bearing adjustment, proper lubrication is essential to the proper function and reliability of your trailer axle. Bearings should be lubricated every 12 months or 12,000 miles (19,312 kilometers). The method to repack bearing cones is as follows:

1. Place a quantity of grease into the palm of your hand.
2. Press a section of the widest end of the bearing into the outer edge of the grease pile closest to the thumb forcing grease into the interior of the bearing.
3. Repeat this while rotating the bearing from roller to roller.
4. Continue this process until you have the entire bearing completely filled with grease.
5. Before reinstalling, apply a light coat of grease on the bearing cup.

BEARING LUBRICATION – OIL

If your axles are equipped with oil lubricated hubs, periodically check and refill the hub as necessary with high quality hypoid gear oil to the level indicated on the clear plastic oil cap. The oil can be filled from either the oil fill hole, if present, in the hub or through the rubber plug hole in the cap itself.

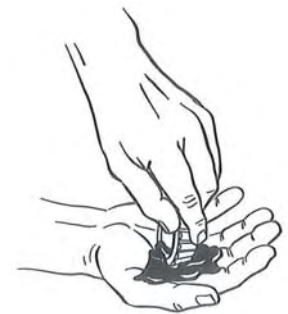

MAINTENANCE (CONTINUED)

TABLE 9-4. RECOMMENDED WHEEL BEARING LUBRICATION SPECIFICATIONS

Grease	
Thicker Type	Lithium Complex
Dropping Point	215°C (419°F) Minimum
Consistency	NLGI No. 2
Additives	EP, Corrosion & Oxidation Inhibitors
Viscosity Index	80 Minimum
Approved Grease Sources	
ConocoPhillips / 76 Lubricants / Kendall	Multiplex RED #2 L427 Super Blu Grease
Citgo	Lithoplex MP #2 Lithoplex CM #2 Mystik JT-6 Hi-Temp Grease #2
Exxon / Mobil Company	Ronex, MP Mobilith AW 2 Mobil I Synthetic Grease
Oil Center Research of Oklahoma	Liquid-O-Ring No. 167L
Pennzoil-Quaker State Company	Synthetic Red Grease
Shell	ALBIDA EP 2 ALBIDA Grease SLC 220 Rotella Heavy Duty Lithium Complex #2
Royal Manufacturing Company	Royal 98 Lithium Complex EP #2
Chevron Texaco	Chevron Ulti-Plex Grease EP #2 Texaco Starplex Moly MPGM #2
Valvoline	Valvoline Multi-Purpose GM Valvoline Durablend
Great Plans Lubricants	Lithium Complex EP #2
Chem Arrow	Arrow 2282
Oil	
SAE 90, SAE 80W-90, SAE 75W-90	
Approved Oil Sources	
Ashland Oil	Valvoline Durablend Valvoline Power Lube
CITGO Petroleum Company	CITGO Premium Gear Oil MP Mystik JT-7 Mystik Power Lube
Exxon Company USA	Gear Oil GX 80W-90
Industrial Oils Unlimited	Super MP Gear Oil 80W90
Kendall Refining Company	Kendall NS-MP Hypoid Gear Lube
Lubriplate Division / Fiske Brothers Refining	Lubriplate APG 90
Mobile Oil Corporation	Mobilube SHC Mobile 1 Synthetic Gear Lube
Phillips 66 Petroleum	Super Multi-Purpose Gear Oil Philguard Gear Oil Philsyn Gear Oil
Pennzoil Products Company	Gear Plus 80W-90 GL-5 Gear Plus Super 75W-90 Gear Plus Super EW 80W-90 Multi-Purpose 4092 Gear Lube
Oil Center Research	Liquid-O-Ring 750 GX
Sun Refining and Marketing Company	Sonoco Ultra Sonoco Dura Gear
Shell Oil Company	Spirax A Spirax G Spirax HD Spirax S
Texaco Oil Company	Multigear EP Multigear SS
Troco Division / Royal Manufacturing	Multigear Select Gear Oil
Union Oil Company	Unocal MP Gear Lube 76 Triton Syn Lube EP

MAINTENANCE (CONTINUED)

NOTE: The convenient lubrication provisions of the E-Z Lube® and the oil lubrication must not replace periodic inspection of the bearings.

SEAL INSPECTION AND REPLACEMENT

Whenever the hub is removed; inspect the seal to assure that it is not kicked or torn and is still capable of properly sealing the bearing cavity. If there is any question of condition, replace the seal. Use only the seals specified in the Seal Replacement Chart.

To replace the seal:

1. Pry the seal out of the hub with a screwdriver. Never drive the seal out with the inner bearing as you may damage the bearing.
2. Apply a PERMATEX sealant to the outside of the new seal.

NOTE: Permatex sealant should not be used on rubber encased seals.

3. Tap the new seal into place using a clean wood block.

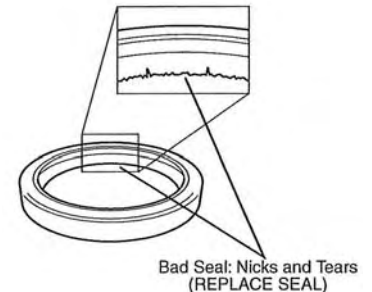
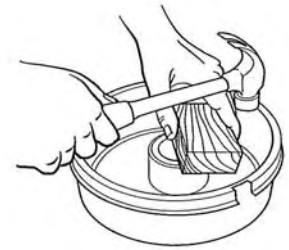

BEARING ADJUSTMENT AND HUB REPLACEMENT

If the hub has been removed or bearing adjustment is required, the following adjustment procedure must be followed:

1. After placing the hub bearings, washers, and spindle nut back on the axle spindle in reverse order as detailed in the previous section on hub removal, rotate the hub assembly slowly while tightening the spindle nut to approximately 50 ft-lb (68 N-m), (12" (30 cm) wrench or pliers with full hand force.)
2. Then loosen the spindle nut to remove the torque. DO NOT rotate the hub.
3. Finger-tighten the spindle nut until just snug.
4. Back the spindle nut out slightly until the first castellation lines up with the cotter key hole and insert the cotter pin.
5. Bend over the cotter pin legs to secure the nut.
6. Nut should be free to move with only restraint being the cotter pin.

For E-Z Lube® axles using the new nut retainer:

1. After placing the hub, bearings, washers and spindle nut back on the axle spindle in reverse order as detailed in the previous section on hub removal, rotate the hub assembly slowly while tightening the spindle nut to approximately 50 ft-lb (68 N-m), (12" (30 cm) wrench or pliers with full hand force.)
2. Then loosen the spindle nut to remove the torque. DO NOT rotate the hub.
3. Finger-tighten the spindle nut until just snug; align the retainer to the machined flat on the spindle and press the retainer onto the nut. The retainer should snap into place. Once in place, the retainer / nut assembly should be free to move slightly.
4. If the nut is too tight, remove the retainer and back the nut off approximately one twelfth of a turn and reinstall the retainer. The nut should now be free to move slightly.
5. Reinstall grease cap.

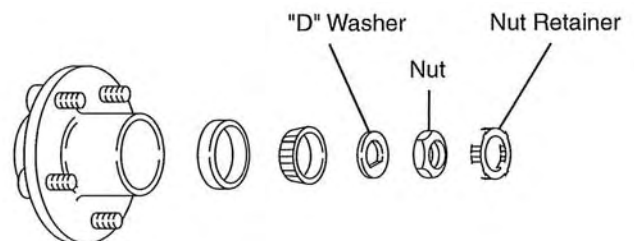

Typical E-Z Lube® After Spring 2002

MAINTENANCE (CONTINUED)

E-Z LUBE® LUBRICATION

The Procedure is as follows:

1. Remove the rubber plug from the end of the grease cap.
2. Place a standard grease gun into the grease fitting located in the end of the spindle. Make sure the grease gun nozzle is fully engaged on the fitting.
3. Pump grease into the fitting. The old displaced grease will begin to flow back out the cap around the grease gun nozzle.
4. When the new clean grease is observed, remove the grease gun, wipe off any excess, and replace the rubber lug in the cap.
5. Rotate hub or drum while adding grease.

NOTE: The E-Z Lube® feature is designed to allow immersion in water. Axles not equipped with E-Z Lube® are not designed for immersion and bearings should be repacked after each immersion. If hubs are removed from an axle with the E-Z Lube® feature, it is imperative that the seals be replaced BEFORE bearing lubrication. Otherwise, the chance of grease getting on brake linings is greatly increased.

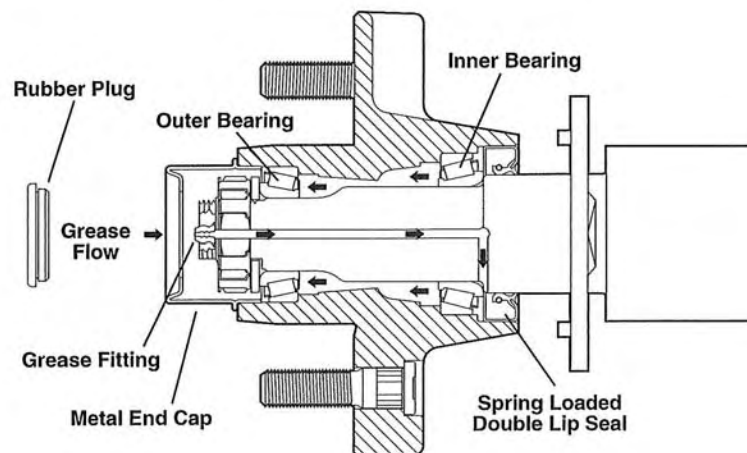

BEARING REPLACEMENT AND DRUM INSTALLATION

1. Once the drum and bearing assembly is removed from the axle, remove "internal snap ring from the bearing bore that retains bearing.
2. Using an arbor press and mandrel, press the bearing out of the drum. Bearing will exit on the wheel side of the drum
3. When replacing a Nev-R-Lube™ bearing pack, the bore in the hub should be cleaned and inspected for visual damage (replace as necessary).
4. Install the new bearing using an arbor press fitted with a hollow or stepped punch face to press only on the outer housing of the bearing. Failure to follow procedure will damage the bearing and / or seals during installation. Press bearing until it seats against the backup shoulder machined into the hub.
5. Install "internal" snap ring into hub.
6. Clean and inspect spindle shaft. Apply a light coating of anti-seize lubricant to the spindle shaft prior to assembling drum.

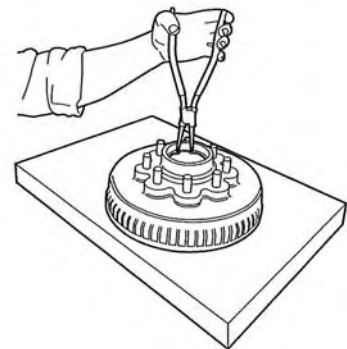

MAINTENANCE (CONTINUED)

7. Install drum assembly onto spindle (**DO NOT** Force).
8. Install steel washer into spindle end.
9. Start self-locking nut into spindle thread by hand. Complete installation using a 1 1/2" or 1 7/16" socket and torque wrench. Nut should be torqued to **145-155 Ft. Lbs (196-210 N-m)**. (This torque will set the internal bearing adjustment; no other adjustments are to be made).
10. Install "torque instruction" washer onto end of spindle.
11. Install "external" snap ring onto end of spindle to retain washer.
12. Inspect assembly for excessive end play, noise, and rotation restriction prior to mounting final wheel end hardware.

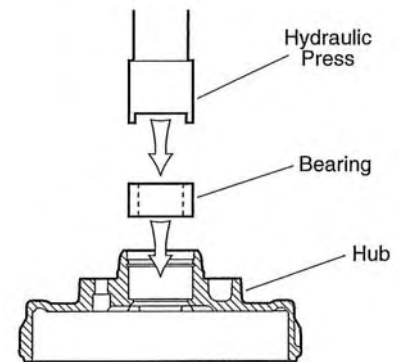

TIRES

Before mounting tires onto the wheels, make certain that the rim size and contour is approved for the tire as shown in the Tire and Rim Association Yearbook or the tire manufacturers catalog. Also make sure the tire will carry the rated load. If the load is not equal on all tires due to trailer weight distribution, use the tire rated for the heaviest wheel position.

NOTE: The capacity rating molded into the sidewall of the tire is not always the proper rating for the tire if used in a trailer application. Use the following guidelines:

1. LT and ST tires. Use the capacity rating molded into the tire.
2. Passenger Car Tires. Use the capacity rating molded into the tire sidewall **divided by 1.10** for trailer use

Use tire mounting procedures as outlined by the Rubber Manufacturer's Association or the tire manufacturers.







Tire inflation pressure is the most important factor in tire life. Inflation pressure should be as recommended by the manufacturer for the load. Pressure should be checked cold before operation. **DO NOT** bleed air from tires when they are hot. Check inflation pressure weekly during use to insure the maximum tire life and tread wear. The following tire wear diagnostic chart will help you pinpoint the causes and solutions of tire wear problems.

CAUTION

Tire wear should be checked frequently because once a wear pattern becomes firmly established in a tire it is difficult to stop, even if the underlying cause is corrected.

MAINTENANCE (CONTINUED)

TABLE 9-5. TIRE WEAR DIAGNOSTIC CHART

Wear Pattern	Cause	Action
	Center Wear Over Inflation	Adjust pressure to particular load per tire catalog
	Edge Wear Under Inflation	Adjust pressure to particular load per tire catalog
	Side Wear Loss of camber or overloading	Make sure load doesn't exceed axle rating. Align at alignment shop
	Toe Wear Incorrect toe-in	Align at alignment shop
	Cupping Out-of-balance	Check bearing adjustment and balance tires
	Flat Spots Wheel lockup & tire skidding	Avoid sudden stops when possible and adjust brakes

HOW TO MEASURE VOLTAGE

System voltage is measured at the magnets by connecting the voltmeter to the two magnet lead wires at any brake. This may be accomplished by using a pin probe inserted through the insulation of wires. The engine of the towing vehicle should be running when checking the voltage so that a low battery will not affect the readings.

Voltage in the system should begin at 0 volts and, as the controller bar is slowly actuated, should gradually increase to about 12 volts. If the controller does not produce this voltage control, consult your controller manual.

The threshold voltage of a controller is the voltage applied to the brakes when the controller first turns on. Lower threshold voltage will provide for smoother braking. If the threshold voltage is too high, the brakes may feel grabby and harsh.

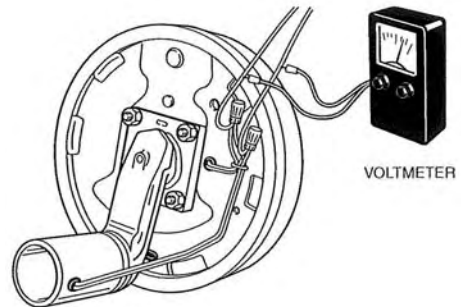
**HOW TO MEASURE AMPERAGE**

System amperage is the current flowing in the system when all the magnets are energized. The amperage will vary in proportion to the voltage. The engine of the tow vehicle should be running with the trailer connected when checking the trailer braking system.

One place to measure system amperage is at the BLUE wire of the controller, which is the output to the brakes. The BLUE wire must be disconnected and the ammeter put in series into the line. System amperage draw should be as noted in the following table. Make sure your ammeter has sufficient capacity and note polarity to prevent damaging your ammeter.

MAINTENANCE (CONTINUED)

TABLE 9-6. MAGNET AMPERES CHART

Brake Size	Amps / Magnet	Two Brakes	Four Brakes	Six Brakes	Magnet / Ohms
7" x 1 1/4"	2.5	5.0	10.0	15.0	3.9
10" x 1 1/2"	3.0	6.0	12.0	18.0	3.2
10" x 2 1/4"	3.0	6.0	12.0	18.0	3.2
12" x 2"	3.0	6.0	12.0	18.0	3.2
12" x 2 1/2"	3.0	6.0	12.0	18.0	3.2
12" x 3 3/8"	3.0	6.0	12.0	18.0	3.2

If a resistor is used in the brake system, it must be set at zero or bypassed completely to obtain the maximum amperage reading. Individual amperage draw can be measured by inserting the ammeter in the line at the magnet you want to check.

Disconnect one of the magnet lead wire connectors and attach the ammeter between the two wires. Make sure that the wires are properly reconnected and sealed after testing is completed.

The most common electrical problem is low or no voltage and amperage at the brakes. Common causes of this condition are:

1. Poor electrical connections
2. Open circuits
3. Insufficient wire size
4. Broken wires
5. Blown fused (fusing of brakes is not recommended)
6. Improperly functioning controllers or resistors

Another common electrical problem is shorted or partially shorted circuits (indicated by abnormally high system amperage). Possible causes are:

1. Shorted magnet coils
2. Defective controllers
3. Bare wires contacting a grounded object

Finding the cause of a short circuit in the system is done by isolating one section at a time. If the high amperage reading drops to zero by unplugging the trailer, then the short is in the trailer. If the amperage reading remains high with all the brake magnets disconnected, the short is in the trailer wiring.

All electrical trouble shooting procedures should start at the controller. Most complaints regarding brake harshness or malfunction are traceable to improperly adjusted or non-functioning controllers. See your controller manufacturer's data for proper adjustment and testing procedures. For best results, all the connection points in the brake wiring should be sealed to prevent corrosion. Loose or corroded connectors will cause an increase in resistance which reduces the voltage available for the brake magnets.

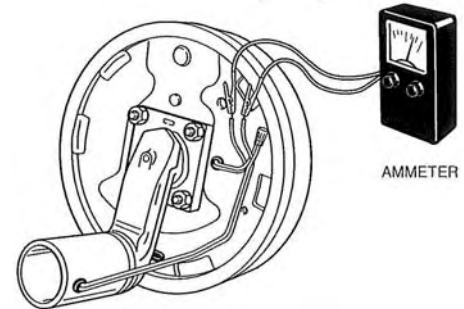

STORAGE

STORAGE PREPARATION

If your trailer is to be stored for an extended period of time or over the winter, it is important that the trailer be prepared properly.

1. Remove the emergency breakaway battery and store inside, out of the weather. Charge the battery at least every 90 days.
2. Jack up the trailer and place jack stands under the trailer frame so that the weight will be off the tires. Follow trailer manufacturer's guidelines to lift and support the unit. Never jack up or place jack stands on the axle tube or on the equalizers.



CAUTION

DO NOT lift or support the trailer on any part of the axle or suspension system. NEVER go under any trailer unless it is properly supported on jack stands which have been rated for the load. Improperly supported vehicles can fall unexpectedly and can cause serious injury or death.

3. Lubricate mechanical moving parts such as the hitch, and suspension parts, that are exposed to the weather.
4. Boat trailer axles are subject to repeated immersion. Before storing, remove brake drums; clean, dry and re-lubricate moving brake components; inspect bearings – clean and re-lubricate.
5. On oil lubricated hubs, the upper part of the roller bearings are not immersed in oil and are subject to potential corrosion. For maximum bearing life, it is recommended that you revolve your wheels periodically (every 2-3 weeks) during periods of prolonged storage.

AFTER PROLONGED STORAGE INSPECTION PROCEDURE

Before removing trailer from jack stands:

1. Remove all wheels and hubs or brake drums. Note which spindle and brake that the drum was removed from so that it can be reinstalled in the same location.
2. Inspect suspension for wear.
3. Check tightness of hanger bolt, shackle bolt, and U-bolt nuts per recommended torque values.
4. Check brake linings, brake drums and armature faces for excessive wear or scoring.
5. Check brake magnets with an ohmmeter. The magnets should check 3.2 ohms. If shorted or worn excessively, they must be replaced.
6. Lubricate all brake moving parts using a high temperature brake lubricant (LUBRIPLATE or Equivalent).

CAUTION

DO NOT get grease or oil on brake linings or magnet face.

7. Remove any rust from braking surface and armature surface of drums with fine emery paper or crocus cloth. Protect bearings from contamination while so doing.

STORAGE (CONTINUED)

8. Inspect oil or grease seals for wear or nicks. Replace if necessary.
9. Lubricate hub bearings. Refer to procedure in this manual.
10. Reinstall hubs and adjust bearings per instructions in this manual.
11. Mount and tighten wheels per instructions in this manual.

TRIP PREPARATION CHECKLIST

There are a number of simple rules to follow in caring for your trailer axle assembly that can add to its life and in the case some of these rules; you may be protecting your own life as well.

Using the following checklist before starting a trip with your trailer is highly recommended. Some of these items should be checked 2-3 weeks prior to a planned trip to allow sufficient time to perform maintenance.

1. Check your maintenance schedule and be sure you are up-to-date.
2. Check hitch. Is it showing wear? Is it properly lubricated?
3. Fasten safety chains and breakaway switch actuating chain securely. Make certain the breakaway battery is fully charged.
4. Inspect towing hookup for secure attachment.
5. Load your trailer so that approximately 10% of the trailers total weight is on the hitch. For light trailers this should be increased to 15%
6. **DO NOT OVERLOAD.** Stay within your gross vehicle rated capacity (consult your trailers identification plate).
7. Inflate tires according to manufacturer's specifications; inspect tires for cuts, excessive wear, etc.
8. Check wheel mounting nuts / bolts with a torque wrench. Torque in proper sequence, to the levels specified in this manual.
9. Make certain the brakes are synchronized and functioning properly.
10. Check tightness of hanger bolt, shackle bolt, and U-bolts nuts per torque values specified in this manual.
11. Check operation of all lights.
12. Check that your trailer is towing in a level position and adjust hitch height if required.

TROUBLE SHOOTING

INTRODUCTION TO TROUBLESHOOTING – HYDRAULIC BRAKING SYSTEM

Proper brake function is critical to the safe operation of any vehicle. A properly installed vacuum / hydraulic, air / hydraulic system should not require any special attention with the exception of routine maintenance as defined by the manufacturer. If problems occur, the entire tow vehicle / trailer braking system should be analyzed by a qualified mechanic. Typical problems in a hydraulic braking system are:

- Air or vacuum leaks
- Hydraulic system leaks
- Air in brakes lines
- Water or other impurity in brake fluid
- Rusted or corroded master or wheel cylinders
- Actuation system malfunction

Please consult the following trouble shooting charts to determine the causes and solutions for common problems found in trailer braking systems.

CAUTION

The operation pressure required for Dexter brakes:

- 7" diameter drum brakes
Maximum operating pressure is 750 psi (52 bar)
- 10" diameter and larger drum brakes
Maximum operating pressure is 1,000 psi (69 bar)
- Hydraulic disc brakes (all sizes)
Maximum operation pressure is 1,600 psi (110 bar)

TROUBLE SHOOTING (CONTINUED)

TABLE 9-7. TROUBLESHOOTING – HYDRAULIC BRAKING SYSTEM

Symptom	Causes	Remedies
No Brakes	Broken or Kinked Brake Line	Repair or Replace
	Severe Under Adjustment	Adjust Brakes
	Malfunctioning Actuation System	Troubleshoot System
Weak Brakes	Brake Adjustment Not Correct	Manual - Adjust Brakes Automatic - Make Several Reverse Stops
	Excessively Worn Brake Linings	Replace Shoe and Lining
	Incorrect Lining	Install Correct Shoe and Lining
	Grease or Fluid Soaked Lining	Repair Grease Seal or Wheel Cylinder. Install New Shoe and Lining.
	Frozen Master Cylinder or Wheel Cylinder Pistons	Recondition or Replace All Cylinders, Brake Fluid
	Glazed Lining	Re-burnish or Replace
	Excessive Drum Wear	Replace
	Trapped Air in Lines	Bleed System
	Overloaded Trailer	Correct
	Malfunctioning Actuation System	Troubleshoot System
Harsh Brakes	Brake Adjustment Not Correct	Manual - Adjust Brakes Automatic - Make Several Reverse Stops
	Grease or Fluid on Linings	Replace Shoes and Lining
Surging Brakes	Grease or Oil on Linings	Clean or Replace
	Out of Round Drums or Cracked Drums	Machine or Replace
Noisy Brakes	Under Adjustment	Adjust
	Lack of Lubrication	Lubricate
	Broken Brake Components	Replace Components
	Incorrect Brake Components	Correct
Locking Brakes	Loose, Bent or Broken Brake Components	Replace Components
	Under Adjustment	Adjust
	Out of Round Drums	Machine or Replace
Pulls to One Side	Incorrect Tire Pressure	Inflate Evenly on Both Sides to Required Pressures
	Unmatched Tires on Same Axle	Match Tires on Axle
	Restricted Brake Lines or Hoses	Repair or Replace
	Malfunctioning Cylinder Assembly	Check for Stuck or Sluggish Pistons
	Defective or Damaged Shoe and Lining	Install New Shoe and Lining - Complete Axle
	One Side Out of Adjustment	Adjust
Dragging	Improper Fluid	Replace Rubber Parts - Fill with DOT4 Fluid
	Blocked Master Cylinder	Open with Compressed Air or Replace Cylinder
	Parking Brake Cable Frozen	Free Cable and Lubricate
	Improper Lining Thickness or Location	Install New Shoe and Lining

TROUBLESHOOTING (CONTINUED)

INTRODUCTION TO TROUBLESHOOTING – ELECTRIC BRAKING SYSTEM

Proper brake function is critical to the safe operation of any vehicle. If problems are encountered with your trailer braking system, the following guide can be used to find the causes and remedies for some of the more common problems. If you are unsure or unable to resolve the problem, please contact your nearest repair facility for professional assistance.

TROUBLESHOOTING

Most electric brake malfunctions that cannot be corrected by either brake adjustments, or synchronization adjustments, can generally be traced to electrical system failure. Voltmeters and ammeters are essential tools for proper troubleshoot of electric brakes.

Mechanical causes are ordinarily obvious, i.e. bent or broken parts, worn out linings or magnets, seized lever arts or shoes, scored drums, loose parts, etc. Replace defective parts with genuine Dexter replacements.

Please consult the following trouble shooting charts to determine the causes and solutions for common problems found in trailer braking systems.

CAUTION

Best braking performance is achieved with a controller setting that is just short of wheel lock up or slide. Overly aggressive braking, which results in wheel lock up and sliding, can cause a dangerous loss of control and result in personal injury or death.

TROUBLE SHOOTING (CONTINUED)

TABLE 9-8. TROUBLESHOOTING - ELECTRIC BRAKING SYSTEM

Symptom	Causes	Remedies
No Brakes	Open Circuits	Find and Correct
	Severe Under Adjustment	Adjust Brakes
	Faulty Controller	Test and Correct
Weak Brakes	Short Circuits	Find and Correct
	Grease or Oil on Magnets or Linings	Clean or Replace
	Corroded Connections	Clean and Correct Cause of Corrosion
	Worn Linings or Magnets	Replace
	Scored or Grooved Brake Drums	Machine or Replace
	Improper Synchronization	Correct
	Under Adjustment	Adjust Brakes
	Glazed Linings	Re-Burnish or Replace
Locking Brakes	Overloaded Trailer	Correct
	Under Adjustment	Adjust
	Improper Synchronization	Correct
	Faulty Controller	Test and Correct
	Loose, Bent or Broken Brake Components	Replace Components
	Out of Round Brake Drums	Machine or Replace
Intermittent Brakes	Insufficient Wheel Load	Adjust System Resistor and Synchronize
	Faulty Controller	Test and Correct
	Broken Wires	Repair or Replace
	Loose Connections	Find and Repair
Brakes Pull to One Side	Faulty Ground	Find and Repair
	Wrong Magnet Lead Wire Color	Correct
	Incorrect Adjustment	Adjust
	Grease or Oil on Magnets or Linings	Clean or Replace
	Broken Wires	Find and Repair
Harsh Brakes	Bad Connections	Find and Repair
	Under Adjustment	Adjust
	Improper Synchronization	Correct
	Improper Controller	Change
Noisy Brakes	Faulty Controller	Test and Correct
	Under Adjustment	Adjust
	Lack of Lubrication	Lubricate
	Broken Brake Components	Replace Components
Surging Brakes	Incorrect Brake Components	Correct
	Grease or Oil on Magnets or Linings	Clean or Replace
	Out of Round or Cracked Brake Drums	Machine or Replace
Dragging	Faulty Controller	Test and Correct
	Over Adjustment	Re-Adjust
	Out of Round Brake Drums	Machine or Replace
	Incorrect Brake Components	Replace
	Loose, Bent or Broken Brake Components	Replace
	Faulty Brake away Switch	Repair or Replace
	Loose Wheel Bearing Adjustment	Adjust
Bent Spindle	Replace Axle	

9B BRADLEY BRAKE ADJUSTMENT

AERIAL WORK PLATFORMS WITH STANDARD BRAKES

1. All brake adjustments must be done with the aerial work platform's wheels off the ground, with the **ROD** and **BRAKE CABLES** completely slack (no tension). Refer to Figure 9-1 for steps 2 through 7.

2. Locate the **BRAKE ADJUSTER NUT** (not shown) on the rear of the **BRAKE BACKER PLATE**.

3. While rotating the wheel in the forward direction, turn the **ADJUSTER NUT** clockwise until the wheel locks, (this centralizes the shoes in the drum).

NOTE: Never turn the wheel in the opposite direction for this adjustment.

4. Loosen, or "back off" the **ADJUSTER NUT**, by turning the nut counterclockwise while rotating the wheel in the forward direction; turn the nut until there is a slight rubbing of the shoes on the drum.

5. Repeat steps 2-4 to adjust the other **BRAKE**.

6. Confirm that the **BRAKE CABLES** are attached at both ends. Each cable has two threaded ends, a dished washer and two nuts, fitted to each cable stud and locked together. Check the end that is connected inside the brake hub first. Next confirm that the **BALANCE BAR** is parallel to the **AXLE BODY**, then check the other end of the **BRAKE CABLE**, it should pass through the **CABLE STOP**, and be secured with a nut, the cable then passes through the **BALANCE BAR** and is secured with a M8 washer (0096-0104) and two M8 nuts (0096-0149) for locking.

NOTE: The washer and nuts must be on the front side of the balance bar.

7. Confirm that the M10 x 1.5 x 82" (A-03677) fully **THREADED ROD (BRAKE ROD)**, passes through the center hole of the **BALANCE BAR** and **CABLE STOP**, and has approximately three inches (3") of the rod behind the **CABLE STOP**. Check that the two (2) M10 nuts (0096-0114) and the dish washer are assembled between the **BALANCE BAR** and **CABLE STOP** (This ensures that the rod will not be pulled through and become unsupported).

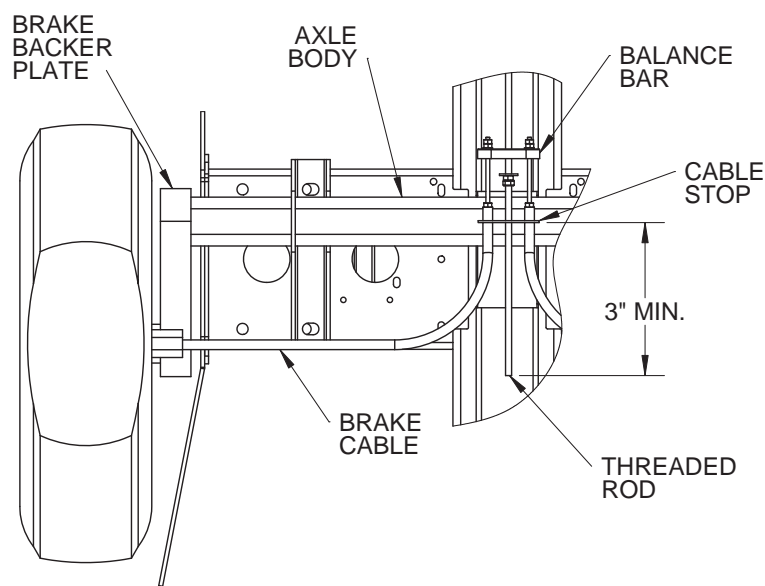

Figure 9-1. Standard Brake Adjustment Procedure

8. Verify that the rod's front end is connected at the **COUPLER**, through the **CLEVIS PIN**, and secured with a M10 lock nut. The rod should not protrude more than 5/8" past the lock nut.

NOTE: DO NOT take the slack out of the rod at this end.

NOTE: If either the coupler or the M10 x 1.5 x 32" rod needs to be replaced this step needs to be performed.

9. Remove the slack out of the **ROD ASSEMBLY** using the M10 nuts (0096-0114) at the **BALANCE BAR**. A minimum 1/8" gap should be left between the nose of the brake link and the rear of the drawbar. If the **BRAKE LEVER** is difficult to pull over center to the point where the **SPRING** becomes operable increase the gap to 3/8" maximum.
10. Remove the "U" clip in the coupler spring and operate the lever two or three times adjusting the nuts on the rod at the **BALANCE BAR** each time to take up slack in **CABLES**. Make sure the gap from step 9 is maintained.
11. Once the slack and stretch is resolved, lock the system off by ensuring all nuts and washers are present and secured.
12. With the parking brake on, rotate the wheels in the reverse direction, this will cause brake "run off" to occur. Both wheels need to be rotated in the reverse direction to properly set the run away brakes. At this point the brakes will lock up the wheels.
13. Disengage the brakes, if the brakes need to be re-adjusted, repeat step 10.
14. The brakes are now ready for the 13 percent Grade Test.

THIRTEEN PERCENT (13 %) GRADE TEST

With the trailer on flat level ground, that is dry and free of ice, perform the following steps to test the brakes.

1. Start by applying the handbrake.
2. Attach a chain to the "chain anchor point", located at the rear of the aerial work platform.
3. Attach a Force Measuring Device (**Load Cell**) to the end of the chain.
4. The opposite end of the **Load Cell** needs to be attached to a fork lift, or a vehicle that can pull the aerial work platform.

NOTE: Ensure that the chain pulls level to ground.

5. Start to pull the aerial work platform backwards; the boom will move a small amount, the coupler handle (brake lever) may "rock" backwards this signifies that the brakes have locked.
6. Read the load reached on the **Load Cell** when the wheels begin to rotate.

NOTE: The peak feature of the **Load Cell** can be use to get the highest load that was reached during the testing.

7. The load reading needs to be 13% of the GVW (gross vehicle weight), for example 2000kg x 0.13 = 260 kg.

NOTE: Bearing in mind that with virgin shoes and drums if you are 10% below this figure it will not be a problem as the system will become more efficient as the brakes "bed in".

AERIAL WORK PLATFORMS WITH DRIVE AND SET BRAKES

1 All brake adjustments must be done with the aerial work platform's wheels off the ground, with the **ROD** and **BRAKE CABLES** completely slack (no tension). Refer to Figure 2 for steps 2 through 7.

2 Locate the **BRAKE ADJUSTER NUT** (not shown) on the rear of the **BRAKE BACKER PLATE**.

3 While rotating the wheel in the forward direction, turn the **ADJUSTER NUT** clockwise until the wheel locks, (this centralizes the shoes in the drum).

NOTE: Never turn the wheel in the opposite direction for this adjustment.

4 Loosen, or "back off" the **ADJUSTER NUT**, by turning the nut counter clockwise while rotating the wheel in the forward direction; turn the nut until there is a slight rubbing of the shoes on the drum.

5 Repeat steps 2-4 to adjust the other brake.

6 Confirm that the **BRAKE CABLES** are attached at both ends. Each cable has two threaded ends, a dished washer and two nuts, fitted to each cable stud and locked together. Check the end that is connected inside the brake hub first. Next confirm that the **BALANCE BAR** is parallel to the **AXLE BODY**, then check the other end of the **BRAKE CABLE**, it should pass through the **CABLE STOP** and should be secured with a nut at the **CABLE STOP**, the cable then passes through the **BALANCE BAR** and is secured with a M8 washer (0096-0104) and two M8 nuts (0096-0149) for locking.

NOTE: The washer and nuts must be on the front side of the **BALANCE BAR**.

7 Confirm that the M10 x 1.5 x 32" (A-03677) fully **THREADED ROD (BRAKE ROD)**, passes through the slots of the **CABLE BRAKE MOUNT** and **BRAKE RELEASE BRACKET**, then through the center holes of the **BALANCE BAR** and **CABLE STOP**, and has approximately three inches (3") of the rod behind the **CABLE STOP**. Check that the two (2) M10 nuts (0096-0114) and the dish washer are assembled between the **BALANCE BAR** and **CABLE STOP**. This ensures that the rod will not be pulled through and become unsupported. Check that two (2) M12 large O.D. washers (0096-0046), one (1) M10 large O.D. washer (0096-0093) and two (2) M10 nuts (0096-0041) are placed between the **BALANCE BAR** and the **BRAKE RELEASE BRACKET**.

NOTE: Make sure that the washer and nuts between the **BALANCE BAR** and the **BRAKE RELEASE BRACKET**, **DO NOT** interfere with the movement of the **THREADED ROD**.

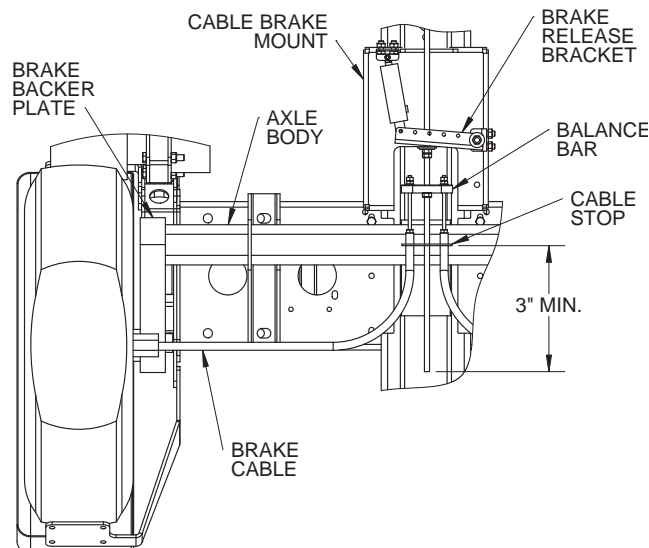

Figure 9-2 Drive & Set Brake Adjustment Procedure

- 8 Verify that the rod's front end is connected at the **COUPLER**, through the **CLEVIS PIN**, and secured with a M10 lock nut. The **ROD** should not protrude more than 5/8" past the lock nut.

NOTE: DO NOT take the slack out of the **ROD** at this end.

NOTE: If either the coupler or the M10 x 1.5 x 32" rod needs to be replaced this step needs to be performed.

- 9 Remove the slack out of the **ROD ASSEMBLY** using the M10 nuts (0096-0114) at the **BALANCE BAR**. A minimum 1/8" gap should be left between the nose of the brake link and the rear of the drawbar. If the **BRAKE LEVER** is difficult to pull over center to the point where the **SPRING** becomes operable increase the gap to 3/8" maximum.
- 10 Remove the "**U**" **CLIP** in the **COUPLER SPRING** and operate lever two or three times adjusting the nuts on the **ROD** at the **BALANCE BAR** each time to take up slack in cables. Make sure the gap from # 9 is maintained.
- 11 With the brakes in the "roll off" position (**ROD** at the maximum travel position forward), the two (2) washers and nuts can now be moved up behind the **BRAKE RELEASE BRACKET**. The distance between washer and bracket must be set as a constant, so that the **BRAKE HANDLE** can reapply the brake when the bracket is released during drive functions, the washer must not interfere with **ROD** movement forward for "roll off" breaking. After correct adjustment has been made the washer positioning nut can be locked in place.

NOTE: If the brake rods are adjusted at this point forward and / or reverse the washers and nuts will also need to be readjusted.

TROUBLESHOOTING THE BRADLEY RUNNING GEAR

1. When the brake lever is on and the vehicle is reversed, if and when both brakes have rolled off and the brake lever has re-applied the brake. The cable balance bar is not parallel to the axle body then one of the brakes is set higher than the other and cannot back off. Adjustment of the brake cables is then required.
2. Always re-adjust the side which has seen the least amount of movement. If the other side has rolled off and cannot be rotated in the reverse direction any further.
3. If the balance bar pulls unevenly in reverse and neither side lock up after roll off then start again with #4 of brake adjustment section. This can also be said for an uneven balance bar in the forward direction.
4. If the brakes are too high the brakes will have difficulty in collapsing into reverse mode.

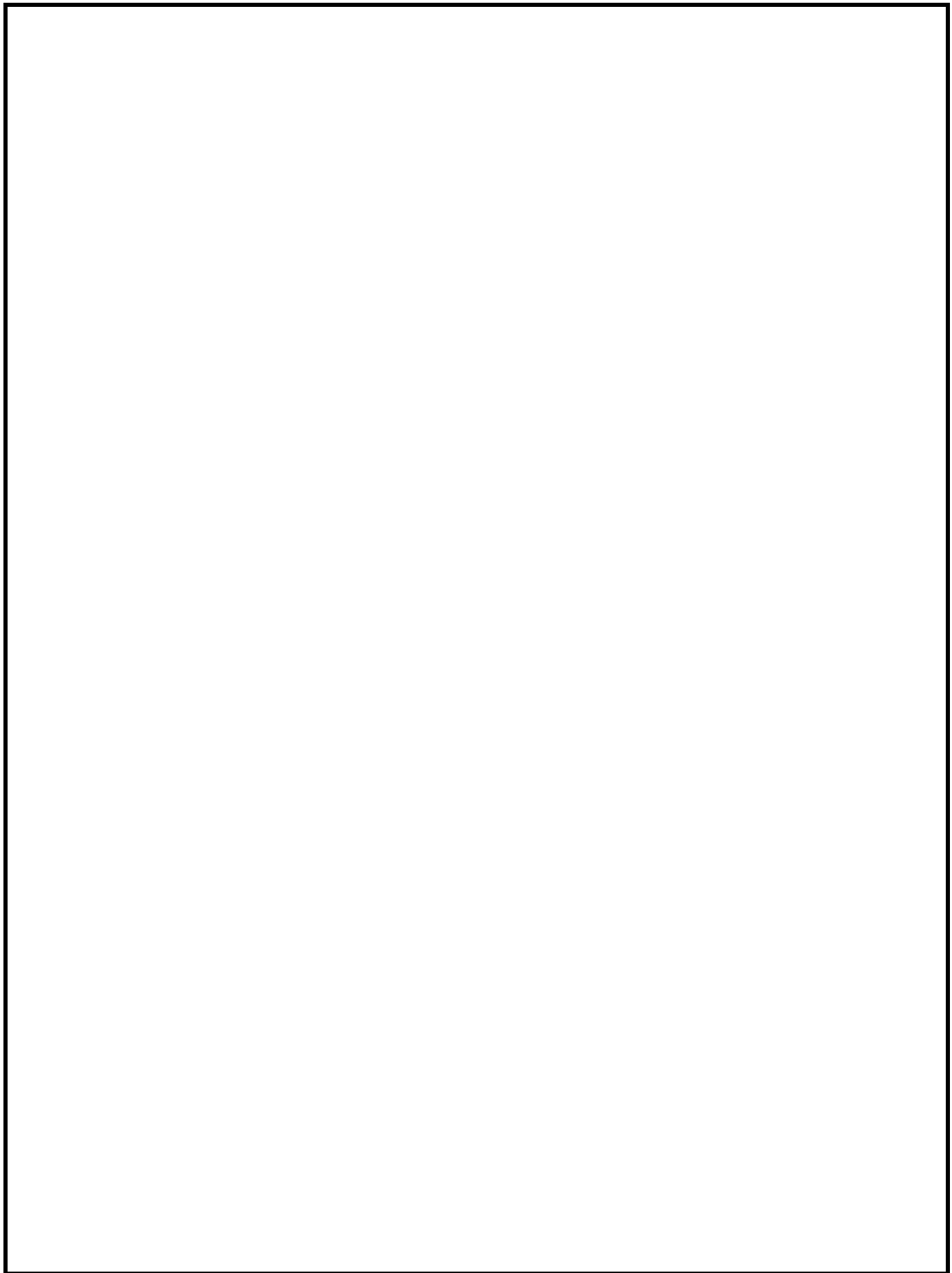

10 ANSI REPRINT

The following sections are reprinted from the ANSI A92.2-2009 code in effect at the time of manufacture and govern the safe use of the Haulotte Group.

It is the responsibility of all owners and operators of this machine to read, understand and obey the recommendations set forth by the ANSI code.

Permission to reprint this material has been granted by the Scaffold Industry Association.

7. Responsibilities of Dealers and Installers

- 7.1 General Responsibilities.** Each dealer or installer as applicable shall comply with the requirements of this section.
- 7.2 Vehicle Specifications.** Each dealer or installer, or both, who sells an aerial device shall inform the owner or user, or both, of the manufacturer's minimum vehicle specifications.
- 7.3 Vehicle Weight Distribution.** The installer shall be responsible for the weight distribution of the completed mobile unit in accordance with the requirements of the aerial device and the applicable regulations. Allowance shall be made for the weight of readily removable tools and material specified by the user.
- 7.4 Manuals.** Upon delivery of the equipment to the owner or user, the dealer or installer shall provide the manuals as required by Paragraph 6.4 of this standard and manuals for auxiliary equipment added by the installer.
- 7.5 Installations.** The installer shall comply with Sections 5 and 6 of this standard relating to proper installation and shall follow the instructions of the manufacturer. In the event the original manufacturer no longer exists, an equivalent entity may provide these instructions. The installer shall maintain access to the lower controls as described in section 4.3.3. The installer of an aerial device shall, before the mobile unit is placed in operation, perform stability tests in accordance with the requirements of 4.5.1 and 4.5.2, the operational and visual tests in accordance with the requirements of 6.6.1 and 6.6.2, and the appropriate electrical tests required in 5.4 of this standard. For insulating aerial devices, the installer shall assure conformance to the Qualification test requirements of 5.3.2 by either obtaining a certification of the test and performing a periodic test after installation, or by performing the Qualification test. The installer shall, when installing an aerial device on a chassis which is a highway vehicle, comply with all requirements of the applicable Federal Motor Vehicle Safety Standards in effect at the time of installation. Certification as a manufacturer (alteration, intermediate or final) of a motor vehicle under the Federal Motor Vehicle Safety Standards is required. The travel height of the mobile unit shall be posted in a location that is readily visible to the vehicle operator.
- 7.6 Quality Assurance.** The installer shall have a documented quality assurance program which will ensure compliance with this standard.
- 7.7 Weldings.** All welds made by the installer, whose failure could result in motion of the platform(s) shall meet the Structural Welding Code AWS D1.1-2006 or AWS DI.2-2003. The installer shall establish applicable welding quality assurance procedures for all weldments.
- 7.8 Training.** The dealer or installer shall offer training or training materials that aid owners, users, operators, lessors and lessees in the operation, inspection, testing and maintenance of the aerial device. This training shall be offered initially and subsequently on request.
- 7.8.1 Dealer or Installer as User.** Whenever a dealer or installer directs personnel to operate an aerial device (inspecting, sales demonstrations, or any form of use), the dealer or installer shall assume the responsibilities of users as specified in Section 9 of this standard. All personnel authorized to operate the aerial device shall have been trained in a program that meets the requirements of this standard.
- 7.9 Maintenance Training.** Dealer maintenance personnel shall be trained in inspection, testing and maintenance of the aerial device in accordance with the manufacturer's recommendations.

8. Responsibilities of Owners

- 8.1 General Responsibilities.** Each owner shall comply with the requirements of this section. The following responsibilities pertain to the owner's inspection, testing, maintenance, modification, training, and transfer of ownership. These activities shall be performed by qualified person(s).
- 8.2 Inspection and Testing Classifications.**
- 8.2.1 Initial Inspection and Test.** Prior to initial use, all new or modified mobile units shall be inspected and tested to ensure compliance with the provisions of this standard. Certification by the manufacturer, dealer, final installer or an equivalent entity(s) meets this requirement.
- 8.2.2 Regular Inspection and Tests.** The inspection procedure for mobile units is divided into two classifications based upon the intervals at which inspections and tests shall be performed. Intervals shall be set by the owner in accordance with the manufacturer's recommendations. Such intervals are dependent upon component function and exposure to wear, deterioration and other agents which adversely affect component life. Two classifications are designated:
- (1) Frequent Inspection and Test: Daily to monthly intervals.
 - (2) Periodic Inspection and Test: One to twelve month intervals.
- 8.2.3 Frequent Inspection and Test.** Items determined by the owner in accordance with the manufacturer's recommendations for each specific aerial device shall be inspected for defects. The following inspections and tests shall be performed by the operator immediately prior to first use at the beginning of each shift:
- (1) Conduct walk around visual inspection looking for damaged components, cracks or corrosion, excessive wear and any loose, deformed or missing bolts, pins, fasteners, locking devices and covers.
 - (2) Check all controls and associated mechanisms for proper operation to include, but not limited to, the following:
 - a) Proper operation of interlocks.
 - b) Controls return to neutral when released and not sticking.
 - c) Control functions and operation clearly marked.

- (3) Check visual and audible safety devices for proper operation.
- (4) Visually inspect fiberglass and insulating components for visible damage and contamination.
- (5) Check for missing or illegible operational and instructional markings.
- (6) Check hydraulic and pneumatic systems for observable deterioration and excessive leakage.
- (7) Check electrical systems related to the aerial device for malfunctions, signs of excessive deterioration, dirt and moisture accumulation.
- (8) Perform functional test to include, but not limited to, the following:
 - (a) Set-up the aerial device for operation, including outriggers.
 - (b) Cycle the aerial device functions through the complete range of motion from the lower controls, except where operation through the complete range of motion would create a hazard.
 - (c) Check functionality of emergency controls.

Any suspected items shall be carefully examined or tested and a determination made by a qualified person as to whether they constitute a safety hazard. All unsafe items shall be replaced or repaired before use.

8.2.4 Periodic Inspection or Test. An inspection of the mobile unit shall be performed at the intervals defined in 8.2.2 depending upon its activity, severity of service, and environment, or as specifically indicated below. (These inspections shall include the requirements of 8.2.3):

- (1) Structural members for deformation, cracks or corrosion.
- (2) Parts, such as pins, bearings, shafts, gears, rollers, locking devices, chains, chain sprockets, wire and synthetic ropes, and sheaves for wear, cracks or distortion.
- (3) Hydraulic and pneumatic relief valve settings.
- (4) Hydraulic system for proper oil level.
- (5) Hydraulic and pneumatic fittings, hoses, and tubing for evidence of leakage, abnormal deformation or excessive abrasion.
- (6) Compressors, pumps, motors, and generators for loose fasteners, leaks, unusual noises or vibrations, loss of operating speed and excessive heating.
- (7) Hydraulic and pneumatic valves for malfunction and visible cracks in the external valve housing, leaks, and sticking spools.
- (8) Visually inspect any vacuum prevention systems and verify function of such systems.
- (9) Hydraulic and pneumatic cylinders and holding valves for malfunction and visible damage.
- (10) Hydraulic and pneumatic filters for cleanliness and the presence of foreign material in the system indicating other component deterioration.
- (11) Electrical systems and components for deterioration or wear including those not readily visible on a frequent inspection.
- (12) Performance test of all boom movements.
- (13) Condition and tightness of bolts and other fasteners in accordance with the manufacturer's recommendation.
- (14) Welds, as specified by the manufacturer.
- (15) Legible and proper identification, operational, and instructional markings.
- (16) If the aerial device is rated as an insulating device, the electrical insulating components and system(s) shall be thoroughly inspected for lack of cleanliness and other conditions that compromise insulation. Then these components and system(s) shall be tested for compliance with the rating of the aerial device in accordance with one of the applicable

methods and procedures as outlined in section 5.4.3 of this standard:

- (a) If the aerial device is used for ac bare-hand work, the 'in the field' tests outlined in 5.4.3.1 (10) (c) may be relied upon when performed frequently, however the unit shall undergo an ac voltage test at least every three years in accordance with Table 2 criteria;
 - (b) If the aerial device is used for dc bare-hand work, the 'in the field' tests outlined in 5.4.3.1 (10) (c) may be relied upon when performed frequently, however the unit shall undergo an appropriate dc over voltage test at least every three years;
 - (c) After repair or replacement of any component that crosses the insulating system(s), or the repair or replacement of an insulating component(s) (e.g., hoses, leveling rods, boom coating, etc.), the unit shall be dielectrically tested in accordance with section 5.4.3;
 - (d) An insulating replacement boom shall be tested to ensure conformance to 5.3.3 by the supplier;
 - (e) Bare-hand work units shall be tested for the applicable unit rating in accordance with Table I (or appropriate dc test for units used on direct current lines, see Appendix B) after any major repair to the insulating boom or any insulating boom replacement. Major repair to the insulating boom shall include resurfacing or repainting of the exterior or interior boom surfaces. The removal and subsequent reinstallation of a gradient control device is not considered a 'major repair' provided proper reinstallation of the gradient control device is performed by a qualified person in accordance with the manufacturer's instructions.
- (17) If the aerial device has upper controls equipped with high electrical resistance components and the manufacturer so indicates, they shall be maintained as high electrical resistance components and should be electrically tested per 5.4.3.6. Any suspected items shall be carefully examined or tested and a determination made by a qualified person as to whether they constitute a safety hazard. All unsafe items shall be replaced or repaired before use.

8.2.5 Post Event Inspection or Test. After any reported event during which structural members of an aerial device or mobile unit are suspected of being subjected to loading or stresses in excess of design stress such as after an accident involving overturning of the mobile unit or application of unintended external mechanical or electrical forces to the aerial device, the aerial device shall be removed from service and subjected to the applicable periodic inspection requirements in 8.2.4. In addition to the periodic inspection, supplemental non-destructive examination procedures or other tests to assist in detecting possible structural damage to the aerial device may be required. All damaged items shall be replaced or repaired before the unit is returned to service. Return to service shall be approved by a qualified person.

8.3 Inspection and Test Records.

8.3.1 Frequent. Items to be inspected shall be designated to the operator or other authorized person making frequent inspections. Records of frequent inspections need not be made. However, where a safety hazard is found, it shall be reported in writing to a person responsible for the corrective action and that report and a record of the

correction shall be maintained for five years, or as required by applicable regulations.

- 8.3.2 Periodic.** Written, or appropriately archived electronic, dated and signed reports and records shall be made of periodic inspections and tests and retained for a period of five years or as required by applicable regulations.
- 8.4 Maintenance.** Maintenance and frequency of maintenance shall be determined by the owner in accordance with the manufacturer's recommendations.
- 8.4.1 Maintenance Training.** The owner shall train their maintenance personnel in inspection and maintenance of the aerial device in accordance with the manufacturer's recommendations and Section 8 of this standard.
- 8.4.2 Weldings.** Welding repairs of components or welds, designated as critical in the manufacturer's manual shall be made in accordance with the manufacturer's recommendations and shall meet the Structural Welding Code AWS D1.1-2006 or AWS D1.2-2003. Should the original manufacturer no longer exist, an equivalent entity may determine the required procedure.
- 8.5 Modifications.** No modifications or additions which affect the stability, mechanical, hydraulic, or electrical integrity or the safe operation of the aerial device shall be made without the written approval of the manufacturer. If such modifications or changes are made, the capacity, operation, and maintenance instruction markings shall be changed accordingly. In no case shall the safety factors be reduced below those specified in this standard or below the manufacturer's design safety factors, whichever are greater. Should the original manufacturer no longer exist, an equivalent entity may approve required modification.
- 8.5.1 Alterations.** Altering or disabling the function of safety devices, guards, or interlocks, if so equipped, is prohibited.
- 8.6 Weight Distribution.** Changes in loading or additions made to the mobile unit after the final acceptance that affect weight distribution shall meet applicable regulations by governmental agencies. In no case shall axle loads of the fully loaded vehicle exceed the Gross Axle Weight Ratings (GAWR) assigned by the manufacturer. Note: Any change in weight distribution may adversely affect stability.
- 8.7 Transfer of Ownership.** When a change in ownership of an aerial device occurs, it shall be the responsibility of the seller to provide the manufacturer's manual(s) for that aerial device to the purchaser. It is the responsibility of the purchaser to notify the manufacturer of the unit model and serial number and the name and address of the new owner within 60 days. If the owner uses other entities as agents (e.g., Brokers) for the sale or the arrangement of a sale of an aerial device(s) their responsibilities under this section continue.
- 8.8 Markings.** The markings on the aerial device shall not be removed, defaced, or altered. All missing or illegible markings shall be promptly replaced.
- 8.9 Parts.** When parts or components are replaced they shall be identical in specification and function to the original aerial device parts or components or shall provide an equal or greater factor of safety.
- 8.10 Safety Bulletins.** Owners shall comply with safety related bulletins as received from the manufacturer, dealer or installer.
- 8.11 Manuals.** The owner shall insure that the operating manual(s) is stored on the mobile unit.

8.12 Training, Retraining, and Familiarization of Operators.

- 8.12.1 General Training.** Only personnel who have received general instructions regarding the inspection, application and operation of aerial devices, including recognition and avoidance of hazards associated with their operation, shall operate an aerial device. Such items covered shall include, but not necessarily be limited to, the following issues and requirements:
- (1) The purpose and use of manuals.
 - (2) That operating manuals are an integral part of the aerial device and must be properly stored on the vehicle when not in use.
 - (3) A pre-start inspection.
 - (4) Responsibilities associated with problems or malfunctions affecting the operation of the aerial device.
 - (5) Factors affecting stability.
 - (6) The purpose of placards and decals.
 - (7) Workplace inspection.
 - (8) Applicable safety rules and regulations, such as Part 4, ANSI C2-2007, National Electrical Safety Code (applies to utility workers as defined in ANSI C2). The above standard is an example; other industries using aerial devices have safety rules pertinent to that industry.
 - (9) Authorization to operate.
 - (10) Operator warnings and instructions.
 - (11) Actual operation of the aerial device. Under the direction of a qualified person, the trainee shall operate the aerial device for a sufficient period of time to demonstrate proficiency in the actual operation of the aerial device.
 - (12) Proper use of personal fall protection equipment. Fall protection systems criteria and practices are covered in 29 CFR 1926.502.
- 8.12.2 Retraining.** The operator shall be retrained, when so directed by the user, based on the user's observation and evaluation of the operator.
- 8.12.3 Familiarization.** When an operator is directed to operate an aerial device they are not familiar with, the operator, prior to operating, shall be instructed regarding the following items:
- (1) The location of the manuals.
 - (2) The purpose and function of all controls.
 - (3) Safety devices and operating characteristics specific to the aerial device.
 - (4) Under the direction of a qualified person, the trainee shall operate the aerial device for a sufficient period of time to demonstrate proficiency in the actual operation of the aerial device.
- 8.13 Owner as a Lessor.** When owners function as lessors, they shall have the same responsibilities as specified under Section 11 of this standard.
- ## 9. Responsibilities of Users.
- 9.1 General Responsibilities.** Each User shall comply with the requirements of this section.
- 9.2 Personnel.** Only trained and authorized personnel shall be permitted to operate the aerial device.
- 9.3 Training, Retraining, and Familiarization of Operators.**
- 9.3.1 General Training.** Only personnel who have received general instructions regarding the inspection, application and operation of aerial devices, including recognition and avoidance of hazards associated with their operation, shall operate an aerial device. Such items covered shall include, but not necessarily be limited to, the following issues and requirements:
- (1) The purpose and use of manuals.

- (2) That operating manuals are an integral part of the aerial device and must be properly stored on the vehicle when not in use.
- (3) A pre-start inspection.
- (4) Responsibilities associated with problems or malfunctions affecting the operation of the aerial device.
- (5) Factors affecting stability.
- (6) The purpose of placards and decals.
- (7) Workplace inspection.
- (8) Applicable safety rules and regulations, such as Part 4, ANSI C2-2007, National Electrical Safety Code. (applies to utility workers as defined in ANSI C2). The above standard is an example; other industries using aerial devices have safety rules pertinent to that industry.
- (9) Authorization to operate.
- (10) Operator warnings and instructions.
- (11) Actual operation of the aerial device. Under the direction of a qualified person, the trainee shall operate the aerial device for a sufficient period of time to demonstrate proficiency in the actual operation of the aerial device.
- (12) Proper use of personal fall protection equipment. Fall protection systems criteria and practices are covered in 29 CFR 1926.502.

9.3.2 Retraining. The operator shall be retrained, when so directed by the user, based on the user's observation and evaluation of the operator.

9.3.3 Familiarization. When operators are directed to operate an aerial device with which they are not familiar, they shall receive prior instruction regarding the following items:

- (1) The location of the manuals.
- (2) The purpose and function of all controls.
- (3) Safety devices and operating characteristics specific to the aerial device.
- (4) Under the direction of a qualified person, the trainee shall operate the aerial device for a sufficient period of time to demonstrate proficiency in the actual operation of the aerial device.

9.3.4 Proof of Training. Users providing training should provide successful trainees a means to evidence their training and should provide such proof if requested by the trainee. The document evidencing training shall include the following information:

- (1) Name of trainee
- (2) Name of entity providing training or retraining
- (3) Name of trainer(s)
- (4) Clear identification of the make(s) and model(s) of the mobile unit(s) on which the operator has been trained.

9.4 Application. The employer and authorized operator(s) shall insure that the aerial device is used only for intended applications as defined in the operating manual and that all recognized safety practices are observed.

Note: The User is directed to Appendix C for guidance as to appropriate applications.

9.5 Electrical Hazard. All applicable safety related work practices intended to protect from electrical hazards shall be defined and explained to the operator by a qualified person. The operator shall maintain the appropriate Minimum Approach Distance (MAD) from energized conductors and apparatus, commensurate with the operator's qualifications. See Appendix F for the information on the Minimum Approach Distances and other precautions.

9.6 Bare-Hand Work. For bare-hand work, a Category A aerial device shall be used.

9.7 Lower Controls. The lower controls of aerial devices shall not be used for continuous operation with personnel in the platform.

9.8 Manufacturer's Safety Bulletins. The user shall comply with the applicable safety-related bulletins as received from the manufacturer, installer, dealer or owner.

10. Responsibilities of Operators

10.1 General Responsibilities. Each operator shall comply with the requirements of this section.

10.2 Personnel. Only trained and authorized personnel shall be permitted to operate the aerial device.

10.3 Operation. During operation of the aerial device all platform occupants shall use appropriate fall protection connected to the aerial device anchorage(s).

10.4 Work Platform. The operator shall not use railings, planks, ladders or any other device in or on the work platform for achieving additional working height or reach.

10.5 Brakes. The vehicle parking brake(s) shall be set at all times that the boom is elevated except when the aerial device is being used in accordance with 10.11.

10.6 Loading. Any loading which includes a horizontal load shall be avoided unless the mobile unit is designed for that application.

10.7 Alterations. Altering or disabling the function of safety devices, guards or interlocks, if so equipped, is prohibited.

10.8 Observations. Observations during operation for any defects shall be conducted on an ongoing basis.

10.8.1 Pre-start Inspection. Items determined by the owner in accordance with the manufacturer's recommendations for each specific aerial device shall be inspected for defects prior to each day's operation. The following tests and inspections shall be performed by the operator once daily, prior to first use:

- (1) Conduct walk around visual inspection, looking for damaged components, cracks or corrosion, excessive wear and any loose, deformed or missing bolts, pins, fasteners, locking devices and covers.
- (2) Check all controls and associated mechanisms for proper operation to include, but not limited to, the following:
 - (a) Proper operation of interlocks.
 - (b) Controls return to neutral when released and not sticking.
 - (c) Control functions and operation clearly marked.
- (3) Check visual and audible safety devices for proper operation.
- (4) Visually inspect fiberglass and insulating components for visible damage and contamination.
- (5) Check for missing or illegible operational and instructional markings.
- (6) Check hydraulic and pneumatic systems for observable deterioration and excessive leakage.
- (7) Check electrical systems related to the aerial device for malfunction, signs of excessive deterioration, dirt, and moisture accumulation.
- (8) Perform functional test to include, but not limited, to the following:
 - (a) Set-up aerial device for operation, including outriggers.
 - (b) Cycle each aerial device boom function through its complete range of motion from the lower controls, except where operation through the complete range of motion would create a hazard.
 - (c) Check functionality of emergency controls.

Any suspected items shall be carefully examined or tested and a determination made by a qualified person as to whether they constitute a safety hazard. All unsafe items shall be replaced or repaired before use.

- 10.9 Worksite.** Before the aerial device is used the worksite shall be surveyed for hazards such as:
- (1) Insufficient supporting surfaces such as soft ground or tamped earth fills.
 - (2) Ditches.
 - (3) Excessive slopes, drop-offs, curbs, and floor obstructions.
 - (4) Debris.
 - (5) Overhead obstructions and electrical conductors.
 - (6) Weather conditions.
 - (7) Presence of unauthorized persons.
 - (8) Road or worksite traffic.
 - (9) Subsurface chambers such as underground utility components or septic systems.
- 10.10 Precautions.** Before and during each use the operator shall:
- (1) Check for overhead obstructions and electrical conductors.
 - (2) Insure that the load on the platform and/or load lifting device is in accordance with the manufacturer's rated capacity.
 - (3) Insure that outriggers and stabilizers are used if the manufacturer's instructions require their use.
 - (4) Insure that guardrails are properly installed, and the gates are closed.
 - (5) Use outrigger pads when necessary to provide firm footing.
- 10.11 Mobile Operation.** Before engaging in mobile operation the operator shall determine that the aerial device is specifically designed for mobile operation.
- 10.11.1 Driver Precautions.** Before and during driving, the driver shall:
- (1) Avoid traveling on any surface that adversely affects vehicle stability.
 - (2) Maintain a safe distance from obstacles and overhead lines.
 - (3) Maintain communications between driver and operator.
 - (4) Responsibilities associated with problems or malfunctions affecting the operation of the aerial device.
- 10.12 Training, Retraining, and Familiarization of Operators.**
- 10.12.1 General Training.** Only personnel who have received general instructions regarding the inspection, application and operation of aerial devices, including recognition and avoidance of hazards associated with their operation, shall operate an aerial device. Such items covered shall include, but not necessarily be limited to, the following issues and requirements:
- (1) The purpose and use of manuals.
 - (2) That operating manuals are an integral part of the aerial device and must be properly stored on the vehicle when not in use.
 - (3) A pre-start inspection.
 - (4) Responsibilities associated with problems or malfunctions affecting the operation of the aerial device.
 - (5) Factors affecting stability.
 - (6) The purpose of placards and decals.
 - (7) Workplace inspection.
 - (8) Applicable safety rules and regulations, such as Part 4, ANSI C2-2007, National Electrical Safety Code (applies to utility workers as defined in ANSI C2). The above standard is an example;

other industries using aerial devices have safety rules pertinent to that industry.

- (9) Authorization to operate.
- (10) Operator warnings and instructions.
- (11) Proper use of personal fall protection equipment. Fall protection systems criteria and practices are covered in 29 CFR 1926.502.

10.12.2 Retraining. The operator shall be retrained, when so directed by the user, based on the user's observation and evaluation of the operator.

10.12.3 Familiarization. When operators are directed to operate an aerial device with which they are not familiar, they shall be instructed, prior to operating the aerial device, regarding the following items:

- (1) The location of the manuals.
- (2) The purpose and function of all controls.
- (3) Safety devices and operating characteristics specific to the aerial device.
- (4) Under the direction of a qualified person, the trainee shall operate the aerial device for a sufficient period of time to demonstrate proficiency in the actual operation of the aerial device.

10.13 Electrical Hazard. All applicable safety related work practices intended to protect personnel from electrical hazards shall be defined and explained to the operator by a qualified person. The operator shall maintain the appropriate Minimum Approach Distance (MAD) from energized conductors and apparatus, commensurate with the operator's qualifications. See Appendix F for information on the Minimum Approach Distance and other precautions.

11. Responsibilities of Lessors or Lessees

11.1 General Responsibilities. Each lessor or lessee shall comply with the requirements of the applicable section or sections below.

11.1.1 Lessor or Lessee as Dealer or Installer. When a lessor or lessee uses the aerial device as a dealer or installer they shall have the same responsibilities as specified under Section 7 of this standard.

11.1.2 Lessor or Lessee as Owner. When a lessor or lessee uses the aerial device as an owner they shall have the same responsibilities as specified under Section 8 of this standard.

11.1.3 Lessor or Lessee as User. When a lessor or lessee uses the aerial device as a user they shall have the same responsibilities as specified under Section 9 of this standard.

11.1.4 Lessor or Lessee as Operator. When a lessor or lessee uses the aerial device as an operator they shall have the same responsibilities as specified under Section 10 of this standard.

11.2 Ownership Responsibilities. The lessor shall carry out the responsibilities of ownership specified in this standard which are not assigned to the lessee as the user.

11.3 Obligations. Upon delivery each lessor of an aerial device shall provide the operators manual and the ANSI/SIA A92.2-2009 Manual of Responsibilities for dealers, owners, users, operators, lessors, lessees and brokers of Vehicle Mounted Elevating and Rotating Aerial Devices. These manuals shall be stored on the mobile unit.

11.3.1 Inspection and Test. Prior to delivery, the lessor of an aerial device shall perform a frequent inspection as specified in Section 8.2.3 of this standard.

11.3.2 Responsibilities. Upon delivery, each lessor of an aerial device shall inform the lessee of their responsibilities in accordance with Section 8 as to inspection, testing and maintenance requirements; Section 9 as to user's responsibilities; and Section 10 as to operator's responsibilities.

11.4 Training. The lessor shall offer training or training materials that aid the lessee in the operation, inspection, testing and maintenance of the aerial device. This training shall be offered initially and subsequently on request.

11.4.1 General training. Only personnel who have received general instructions regarding the inspection, application and operation of aerial devices, including recognition and avoidance of hazards associated with their operation, shall operate an aerial device. Such items covered shall include, but not necessarily be limited to, the following issues and requirements:

- (1) The purpose and use of manuals.
- (2) That operating manuals are an integral part of the aerial device and must be properly stored on the vehicle when not in use.
- (3) A pre-start inspection.
- (4) Responsibilities associated with problems or malfunctions affecting the operation of the aerial device.
- (5) Factors affecting stability.
- (6) The purpose of placards and decals.
- (7) Workplace inspection.
- (8) Applicable safety rules and regulations, such as Part 4, ANSI C2-2007, National Electrical Safety Code (applies to utility workers as defined in ANSI C2). The above standard is an example; other industries using aerial devices have safety rules pertinent to that industry.
- (9) Authorization to operate.
- (10) Operator warnings and instructions.
- (11) Proper use of personal fall protection equipment. Fall protection systems criteria and practices are covered in 29 CFR 1926.502.
- (12) Electrical hazards and Minimum Approach Distance to energized conductors and apparatus. See Appendix F.

11.4.2 Familiarization. When operators are directed to operate an aerial device with which they are not familiar, they

shall be instructed, prior to operating the aerial device, regarding the following items:

- (1) The location of the manuals.
- (2) The purpose and function of all controls.
- (3) Safety devices and operating characteristics specific to the aerial device.
- (4) Under the direction of a qualified person, the trainee shall operate the aerial device for a sufficient period of time to demonstrate proficiency in the actual operation of the aerial device.

11.5 Communications. In the event the manufacturer or installer provides the lessor manuals, bulletins, or other materials for the information of the user of an aerial device, the lessor shall pass them on to the user without delay.

11.6 Use of Brokers. If Brokers are employed in leasing, the responsibility of lessors and lessees as specified in this Section continue even though a Broker may be involved in the transaction.

12. Responsibilities of Brokers

12.1 Broker Involved In a Sale. A broker involved in a sale shall:

- (1) Assure that the entity actually transferring ownership knows the proper location and identification of proper personnel of the purchasing entity.
- (2) Confirm that operations and maintenance manuals are provided to the new owner.
- (3) Confirm that all parties are aware of their responsibilities under Section 8.7 of this standard.

12.2 Broker Involved In a Lease. A broker involved in a lease shall:

- (1) Assure that the entity actually transferring possession knows the proper location and identification of the proper personnel of the lessee or user of the aerial device.
- (2) Confirm that the operators' manual, maintenance manual, and a Manual of Responsibilities are provided to the lessee.
- (3) Confirm that all parties are aware of their responsibilities under Section 11.4 of this standard.

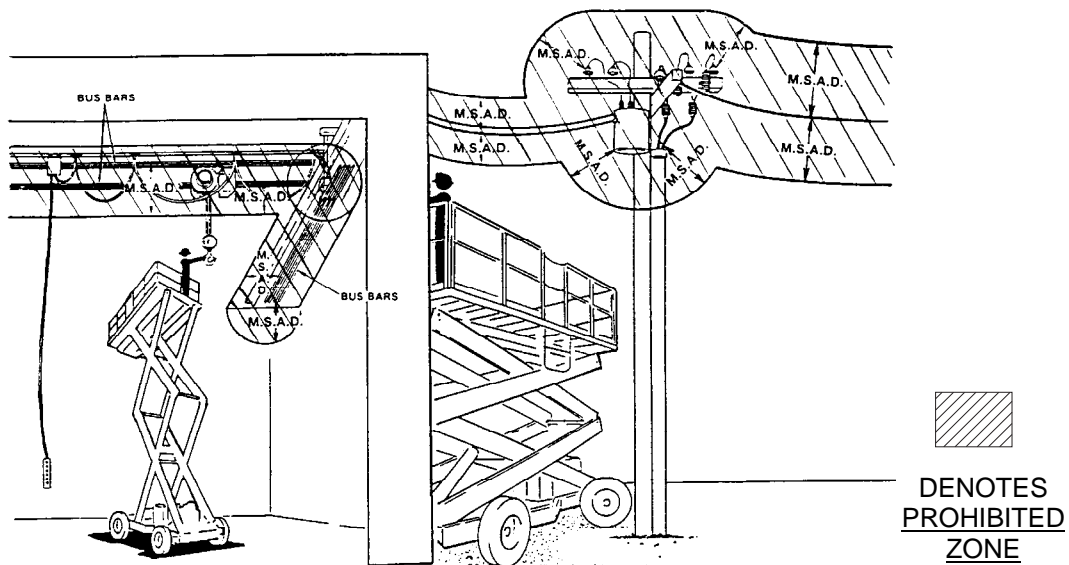

Figure 10-1. Minimum Safe Approach Distance

TABLE 10-1. MINIMUM SAFE APPROACH DISTANCES		
Voltage Range (Phase to Phase)	Minimum Safe Approach Distance	
	(Feet)	(Meters)
0 to 300V	Avoid Contact	
Over 300V to 50KV	10	3.05
Over 50KV to 200KV	15	4.60
Over 200KV to 350KV	20	6.10
Over 350KV to 500KV	25	7.62
Over 500KV to 750KV	35	10.67
Over 750KV to 1000KV	45	13.72

DANGER

DO NOT allow aerial work platform, personnel, or conductive materials inside prohibited zone. Maintain M.S.A.D from all energized lines and parts as well as those shown. Assume all electrical parts and wires are energized unless known otherwise. Failure to avoid energized power sources will result in death or serious injury.

CAUTION

Diagrams shown are only for purposes of illustration M.S.A.D. work positions, not all work positions.

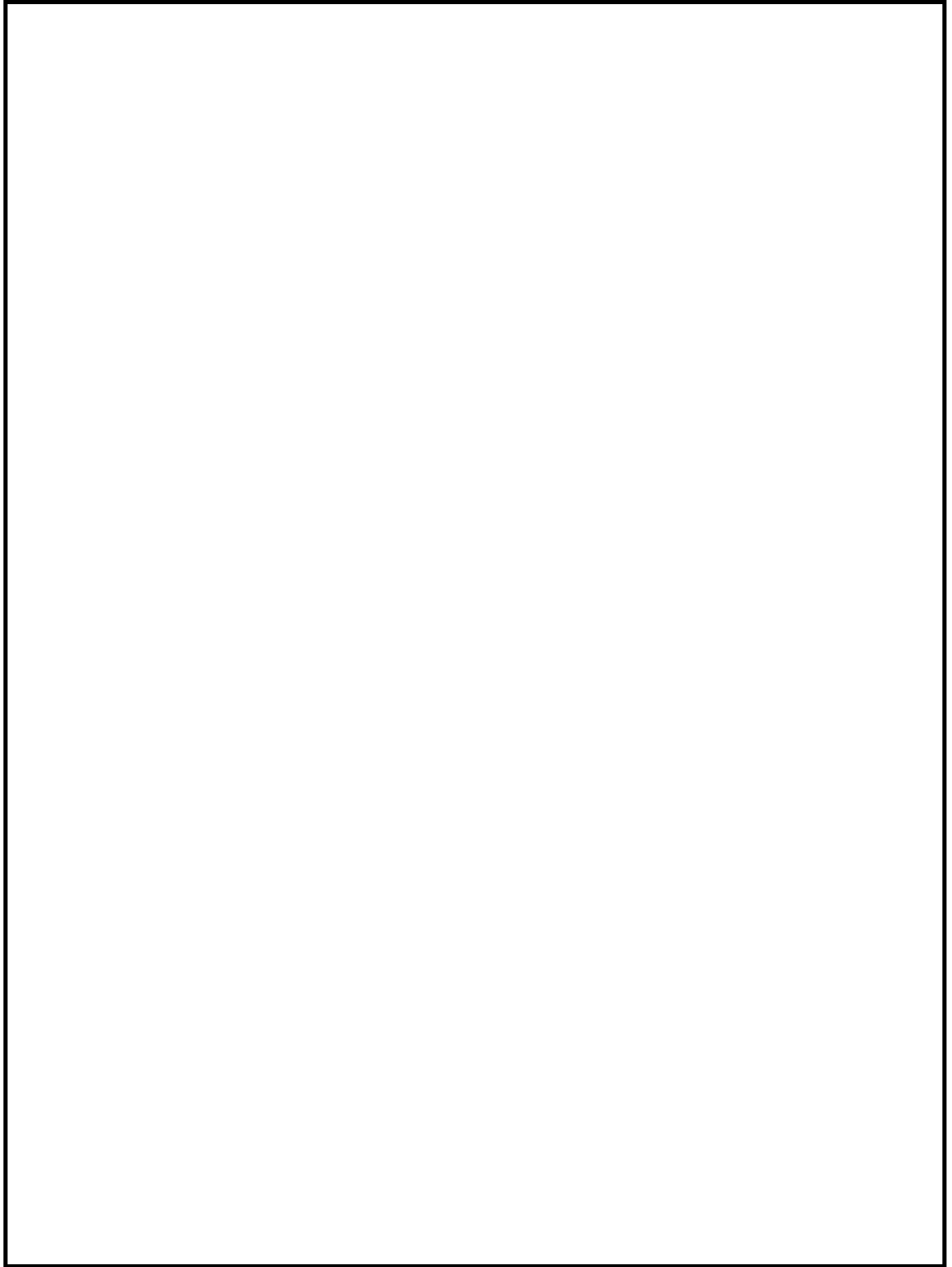

INSPECTION FORM FOR HAULOTTE AERIAL WORK PLATFORMS

Machine Model No.		Serial No.	
Date of Manufacture:		Inspection Performed by:	
Date of Inspection:		Inspection Location:	

Inspection and Maintenance of the above listed machine shall be performed only by fully trained, authorized and, where applicable, certified personnel. All service checks shall be performed in accordance with manufacturer's recommendations (Refer to the Equipment Maintenance section of this manual). Copy this form as needed. Direct any questions to the Haulotte Group Customer Service Department: at 1-800-537-0540 or visit Haulotte Group online at www.haulotte-usa.com.

Inspector: Initial in the space provided beside each service check as it is completed. Sign and date form after Inspection.
Owner: Keep this form for your records.

Frequency Key:

D=Daily (or before each use); W=Weekly; M=Monthly; A=Annually; SA= Semi-Annually

Service Check Descriptions	Frequency	Initials
Verify that all decals are legible, correctly applied and in plain view.	D	
Verify that all controls and indicators at the ground and platform control stations operate properly.	D	
Verify operation of running and brake lights.	D	
Verify proper tire inflation. See the side wall of the tire for proper inflation.	D	
Inspect tires for damage, or loose or missing lug nuts.	D	
Inspect structural components for obvious damage or debris.	D	
Inspect machine for loose, damaged or missing fasteners, including pins and bolts.	D	
Verify that the boom down limit switches operate correctly.	D	
Verify that outrigger safety interlocks operate correctly.	D	
Inspect hydraulic system and fluid levels.	D	
Check battery electrolyte level.	W	
Inspect electrical wiring for damaged, broken or frayed wires.	W	
Inspect transport hitch for damage.	W	
Inspect boom for missing, loose or damaged hardware.	W	
Inspect all hydraulic system components including power unit, hoses and cylinders, for damage, leaks, loss of pressure or speed, and unusual noise or vibration.	W	
Check Engine oil. Applicable for machines equipped with Engines.	W	
Clean all battery terminals.	M	
Check battery connections.	M	
Verify proper operation of manual lowering valves and hand pump.	M	
Lubricate all compartment hinges and latches, slew ring and mating gear using NLGI Grade 2 multi-purpose grease.	M	
Check Wheel Nut torque.	M	
Check coolant level. Applicable for machines equipped with Engines.	M	
Inspect the Air Filter. Applicable for machines equipped with Engines.	M	
Verify proper level sensor operation (use outriggers to tilt machine, try to operate boom functions).	M	
Check Drive Belt tension.	SA	
Verify Engine rpm. Applicable for machines equipped with Engines.	SA	
Add or replace Hydraulic Oil and Hydraulic Filter annually, replace more frequently in dirty conditions.	A	
Inspect pivot pins and cylinders, including rod ends for wear or damage.	A	
Visually inspect all welds for wear, damage or corrosion.	A	
Inspect outriggers for wear or damage.	A	
Inspect axle and parking brake, adjust as necessary.	A	
Load test all boom functions with a 500lb (227kg) load (440lb/200kg load if machine is equipped with jib/platform rotate).	A	
Check slew ring for wear or damage.	A	

** Refer to Engine Operators Manual for recommended Engine Maintenance

Inspector Signature _____ **Date** ___ / ___ / ___



125 Taylor Parkway
Archbold, Ohio 43502

Phone (800) 537-0540
(419) 445-8915

Fax (419) 445-0367

www.haulotte-usa.com

Distributed by: