

World's Best Drywall Lifts™

Genuine **PANELLIFT** **USA**
Brand ®

PATENT NO. 5,368,429 5,586,619 5,984,605 Other patents pending.

OPERATOR'S MANUAL

For Model 195 Loader Attachment

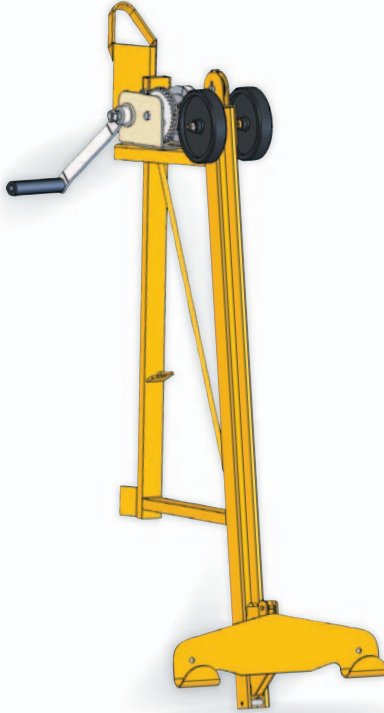

⚠ WARNING ⚠

Read and become familiar with this manual **BEFORE** operating unit.

Before operating this equipment, thoroughly read this set of instructions, make sure you understand them, and only then follow the step-by-step directions. Failure to do so could result in serious property damage and / or serious bodily injury.

To our valued customer:

Thank you for choosing the PANELLIFT® Loader Attachment. We are pleased that we are able to provide equipment to make your work easier.

Our efforts are focused on producing the finest quality equipment of which we are capable. We know that extra time and effort spent on our part to design and produce a high quality finished product will mean time and effort saved on your part when you use it. This is important to us.

Foundational to all of our work at Telpro Inc. is the fact that God is our creator. It is our desire to honor him in our work and business relationships. We are able to provide equipment to ease only your physical labor. But Jesus said, "Come to me, all you who are weary and burdened, and I will give you rest. Take my yoke upon you and learn from me, for I am gentle and humble in heart, and you will find rest for your souls. For my yoke is easy and my burden light."

Jesus also said, "I have come that they might have life, and have it to the full." The Apostle Peter said, "Salvation is to be found through him alone; in all the world there is no one else whom God has given who can save us...Leave all your worries with him because he cares for you."

Thank you again for giving us the opportunity to work with you. Any questions or comments that you may have regarding our equipment or company are always welcome.

Telpro Inc.

CONTENTS

Warning / Instructional Information.....Page 3

Initial Assembly.....Pages 4-5

Operation.....Page 6

Parts Index.....Page 7

Order Form.....Page 8

Warning

Read and follow these warnings and the instructions that follow. Failure to do so could result in serious property damage and/or serious bodily injury.

• **BEFORE** operating this equipment, thoroughly read this set of instructions, make sure you understand them, and only then follow the step-by-step directions.

FAILURE TO READ AND FOLLOW THESE INSTRUCTIONS could result in failure of the equipment. Failure of the equipment while the lift is raised can include a sudden and rapid lowering of the lift and load possibly resulting in serious property damage and/or serious bodily injury.

- The PANELLIFT® Drywall Lift Loader Attachment is designed and intended for use **ONLY** in combination with PANELLIFT® brand drywall lifts, made by Telpro Inc. **DO NOT** use the loader attachment with any other type of lift. Failure to follow this warning may result in property damage and/or personal injury.
- Use and maintenance of the PANELLIFT® Drywall Lift and loader shall be limited to authorized personnel who are trained in the proper techniques for its safe operation and maintenance and who are familiar with the various hazards of overhead material handling.
- As with any lifting equipment, **ALWAYS WEAR A HARD HAT** when operating the PANELLIFT® Drywall Lift and keep children away from the work area. Failure to do so could result in serious bodily injury.
- **DO NOT ATTEMPT TO USE YOUR PANELLIFT® Drywall Lift loader attachment IF ANY PART IS MISSING, DAMAGED OR WORN. ORDER A REPLACEMENT PART IMMEDIATELY.** Using a PANELLIFT® Drywall Lift loader attachment with missing, damaged or worn components can result in failure of the unit and possibly severe property damage and/or serious bodily injury.
- **INSPECT THE CABLE BEFORE EACH USE. REPLACE AT THE FIRST SIGN OF**

DAMAGE OR WEAR. A worn, damaged or improperly installed cable can fail resulting in a sudden and rapid lowering of the lift and the load and possibly resulting in serious property damage and/or serious bodily injury.

- **The weight capacity of the PANELLIFT® Drywall Lift and loader attachment is 150 lbs. (68 kg). DO NOT load the unit beyond this limit. Load only one sheet of wallboard at a time.** Failure to follow this warning can result in an unstable load and/or damage to the PANELLIFT® Drywall Lift contributing to a sudden failure of the machine and serious property damage and/or serious bodily injury.
- The PANELLIFT® Drywall Lift and loader attachment are designed exclusively as a material lift and shall be used for no other purpose. The PANELLIFT® Drywall Lift and loader attachment is not a personnel lift or platform and shall not be used as such. Using the PANELLIFT® Drywall Lift for purposes other than a material lift can subject the unit to stresses and loads that it was not designed to carry. This can result in failure of the unit which may include a sudden and rapid lowering of the lift and the load possibly resulting in serious property damage and/or serious bodily injury.
- The PANELLIFT® Drywall Lift and loader attachment are made of steel which conducts electricity. **KEEP THE UNIT AWAY FROM LIVE ELECTRICAL WIRES.** Failure to do so could result in electrocution.
- Use only factory authorized replacement parts. Installation of other parts can compromise the safe design of the PANELLIFT® Drywall Lift loader attachment and may cause failure of the unit possibly resulting in serious property damage and/or serious bodily injury.
- Operate only on hard, level surface at room temperature in a dry environment.

**Questions? - Call Telpro Inc. Customer Service at:
1-800-448-0822 or 701-775-0551**

INITIAL ASSEMBLY

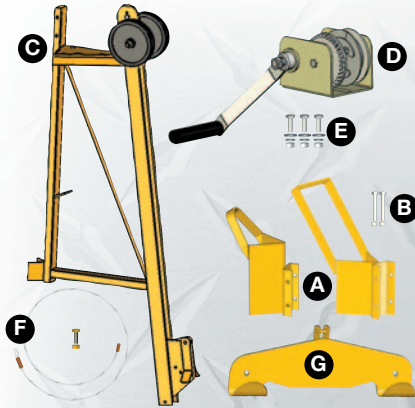

1. Unpack contents and ensure that you have these items:

- A. Two Mount Brackets
- B. 1/4" X 2 1/4" bolts w/ nuts (2)
- C. Frame Assembly w/ guide wheels & roller pocket
- D. Winch
- E. 3/8" X 1" bolts w/ flat washers, lock washers and nuts (3)
- F. Cable w/ 1/4" X 1" bolt and nut
- G. Foot Bracket



2. Select the correct mount bracket that corresponds to the model of PANELLIFT® drywall lift you are using:

- Bracket "A" is for use with PANELLIFT® drywall lift models 138-2 and 182.
- Bracket "B" is for use with PANELLIFT® drywall lift models 439 and 460.

If you are in doubt as to which model of PANELLIFT® drywall lift you are using call us at Telpro Inc. and we'll help you identify it.

(800) 448-0822 or (701) 775-0551

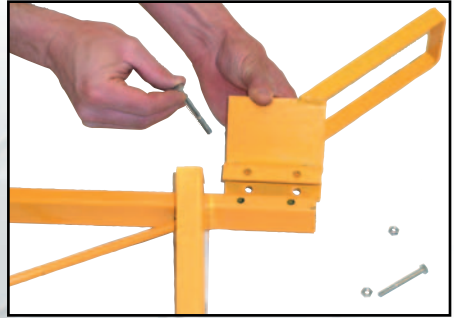

3. Attach the bracket to the loader frame using the 1/4" X 2 1/4" bolts and lock nuts.



4. Hang the loader on the PANELLIFT® drywall lift frame.

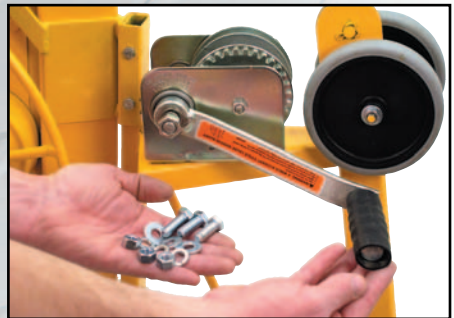

5. Attach the winch to the loader frame using the 3/8" X 1" bolts with fasteners. NOTE: Install the bolts with flat washers from the top down through the winch and fasten the lock washers and nuts from underneath the winch mount plate.

INITIAL ASSEMBLY continued



6. Pass the crimped end of the cable over the sheave pocket as shown.

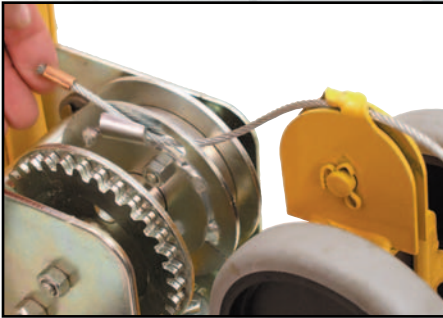

7. Insert the crimped end of the cable through the oblong hole in the winch flange and behind the mooring tab as shown.

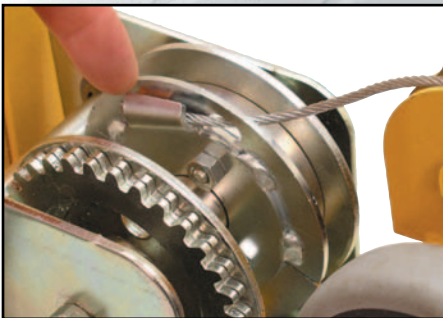

8. Pull the slack out of the cable to seat the crimped end securely behind the mooring tab as shown.

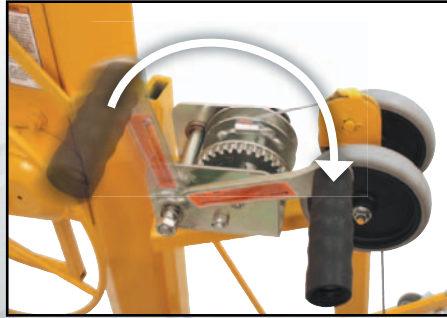

9. Rotate the winch handle clockwise to take up the slack in the cable around the winch drum.



10. Push back on the foot bracket latch, insert the bracket, and release latch.



11. Insert the cradle on the PANELLIFT® Drywall Lift and you're ready to lift drywall from floor to ceiling.

OPERATION



1. To load, lift board by one end and place in the foot bracket making sure it is centered on the bracket.



2. Raise the board by rotating the winch handle.



3. When the board is fully raised, swing the cross arm support hooks under the board.



4. Raise the board off the loader foot bracket by rotating the PANELLIFT® Drywall Lift winch slightly and tilt the board to horizontal.



5. Install the board as normal using your PANELLIFT® Drywall Lift.

PARTS INDEX LOADER ATTACHMENT 195

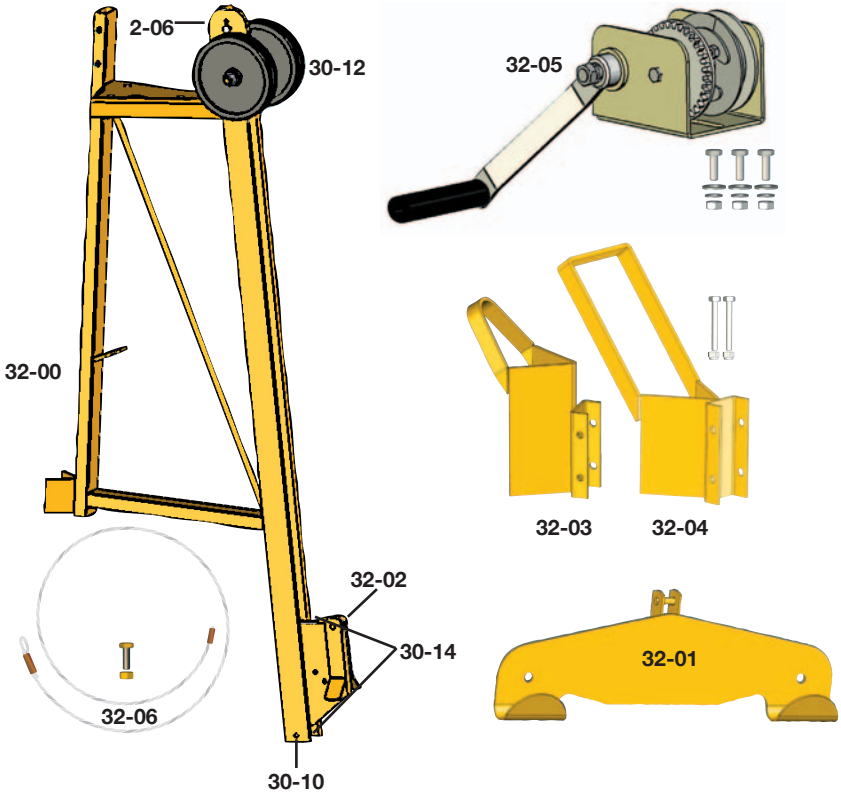

PARTS LIST:

Part#	Description
2-06	Cable Sheave w/ Axle & Pins
30-10	Stop Bolt w/ Fasteners
30-12	Guide Wheel w/ Fasteners
30-14	Lift Bracket Rollers
32-00	Frame
32-01	Foot Bracket
32-02	Roller Pocket
32-03	Mount Bracket w/ Fasteners 138-2/182
32-04	Mount Bracket w/ Fasteners 439/460
32-05	Loader Winch w/ Fasteners
32-06	Cable 48"

Telpro Inc.

To Order Parts Call: 1(800) 448-0822

ORDER FORM

COPY THIS ORDER FORM TO PLACE ORDERS
PHONE 1-800-448-0822 FAX 1-800-474-9993
E-MAIL telpromktg@telproinc.com

Quantity	Part #	Description	Price Each	Total Price

MAIL ORDER TO:
Telpro Inc.
 ATTN: Sales Dept.
 7251 South 42nd St.
 Grand Forks, ND 58201
www.telproinc.com

Sub Total		
Shipping		
Total		

- VISA
- MC
- DISCOVER
- AM EX

- CHECK
- MONEY ORDER

CARD#

--	--	--	--	--	--	--	--	--	--	--	--	--	--	--	--	--	--	--	--

EXP. DATE

--	--	--	--

*CVV2 #

--	--	--	--

SIGNATURE (required for credit card purchases)

 Ship to Name (Please print clearly)

 Address

 City State Zip Code

 Phone #

Shipping address must be the same as billing address

*CVV2 is an authentication process established by credit card companies to reduce fraud for internet transactions. It consists of requiring a card holder to enter the CVV2 number in at transaction time to verify the card is on hand. For VISA, MASTERCARD, or DISCOVER, the 3 digit number is found on the back of the card. This number is printed on the signature area (last 3 digits after the card number). For AMERICAN EXPRESS cards, the 4 digit number is printed above to the right of the imprinted credit card number on the front of the card. Please call Telpro at 1.800.448.0822 if you have questions.