

OPERATION AND PARTS MANUAL



***WHITEMAN* SERIES**

MODEL WBH16

**(GX390RT2QTT GASOLINE ENGINE
RECOIL START)**

MODEL WBH16E

**(GX390RT2QNB2 GASOLINE ENGINE
ELECTRIC START)**

Serial No. 110401 and ABOVE

POWER BUGGY

Revision #0 (06/14/11)

To find the latest revision of this
publication, visit our website at:
www.multiquip.com



THIS MANUAL MUST ACCOMPANY THE EQUIPMENT AT ALL TIMES.



CALIFORNIA — Proposition 65 Warning

Engine exhaust and some of its constituents, and some dust created by power sanding, sawing, grinding, drilling and other construction activities contains chemicals known to the State of California to cause cancer, birth defects and other reproductive harm.

Some examples of these chemicals are:

- Lead from lead-based paints.
- Crystalline silica from bricks.
- Cement and other masonry products.
- Arsenic and chromium from chemically treated lumber.

Your risk from these exposures varies, depending on how often you do this type of work. To reduce your exposure to these chemicals: **ALWAYS** work in a well ventilated area, and work with approved safety equipment, such as dust masks that are specially designed to filter out microscopic particles.

TABLE OF CONTENTS

WBH16/WBH16E Power Buggy

Proposition 65 Warning	2
Table Of Contents	3
Parts Ordering Procedures.....	4
Safety Information	5-10
Specifications	11-12
Dimensions.....	13
General Information.....	14
Components	15
Basic Engine.....	16
Inspection	17-18
Operation.....	19-23
Maintenance	24-25
Troubleshooting	26-28
Hydraulic System Diagram	29
Explanation Of Code In Remarks Column.....	30
Suggested Spare Parts	31

Component Drawings

Nameplate And Decals.....	32-33
Hydraulic Drive Assy.....	34-35
Hydraulic Pump Assy.....	36-37
Hydraulic Dump Assy.....	38-39
Pump And Coupling Assy.	40-41
Tub Assy.....	42-43
Panel Assy.	44-45
Brake Assy.....	46-47
Steering Assy.....	48-49
Chassis Assy.....	50-51
Dump Pedal And Handle Assy.....	52-53
Hydraulic Oil Tank Assy.....	54-55
Battery Assy. (Electric Start).....	56-57
Fuel Assy.	58-59
Engine Assy.....	60-61
Terms And Conditions Of Sale — Parts	62

NOTICE

Specifications and part numbers are subject to change without notice.

PARTS ORDERING PROCEDURES

www.multiquip.com

Ordering parts has never been easier! Choose from three easy options:

Effective:
January 1st, 2006



Order via Internet (Dealers Only):

Order parts on-line using Multiquip's SmartEquip website!

- View Parts Diagrams
- Order Parts
- Print Specification Information



If you have an MQ Account, to obtain a Username and Password, E-mail us at: parts@multiquip.com.

To obtain an MQ Account, contact your District Sales Manager for more information.

Goto www.multiquip.com and click on **Order Parts** to log in and save!

Use the **internet** and qualify for a **5% Discount** on *Standard orders* for all orders which include complete part numbers.*

Note: Discounts Are Subject To Change



Order via Fax (Dealers Only):

All customers are welcome to order parts via Fax.

Domestic (US) Customers dial:
1-800-6-PARTS-7 (800-672-7877)

Fax your order in and qualify for a **2% Discount** on *Standard orders* for all orders which include complete part numbers.*

Note: Discounts Are Subject To Change



Order via Phone: Domestic (US) Dealers Call:
1-800-427-1244

Non-Dealer Customers:

Contact your local Multiquip Dealer for parts or call 800-427-1244 for help in locating a dealer near you.



International Customers should contact their local Multiquip Representatives for Parts Ordering information.

When ordering parts, please supply:

- | | |
|---|--|
| <input type="checkbox"/> Dealer Account Number | <input type="checkbox"/> Specify Preferred Method of Shipment: |
| <input type="checkbox"/> Dealer Name and Address | <input checked="" type="checkbox"/> UPS/Fed Ex <input checked="" type="checkbox"/> DHL |
| <input type="checkbox"/> Shipping Address (if different than billing address) | <input type="checkbox"/> Priority One <input checked="" type="checkbox"/> Truck |
| <input type="checkbox"/> Return Fax Number | <input type="checkbox"/> Ground |
| <input type="checkbox"/> Applicable Model Number | <input type="checkbox"/> Next Day |
| <input type="checkbox"/> Quantity, Part Number and Description of Each Part | <input type="checkbox"/> Second/Third Day |

NOTICE

All orders are treated as *Standard Orders* and will ship the same day if received prior to 3PM PST.

WE ACCEPT ALL MAJOR CREDIT CARDS!



SAFETY INFORMATION

Do not operate or service the equipment before reading the entire manual. Safety precautions should be followed at all times when operating this equipment. Failure to read and understand the safety messages and operating instructions could result in injury to yourself and others.



SAFETY MESSAGES

The four safety messages shown below will inform you about potential hazards that could injure you or others. The safety messages specifically address the level of exposure to the operator and are preceded by one of four words: **DANGER**, **WARNING**, **CAUTION** or **NOTICE**.

SAFETY SYMBOLS

 **DANGER**

Indicates a hazardous situation which, if not avoided, **WILL** result in **DEATH** or **SERIOUS INJURY**.

 **WARNING**

Indicates a hazardous situation which, if not avoided, **COULD** result in **DEATH** or **SERIOUS INJURY**.





 **CAUTION**

Indicates a hazardous situation which, if not avoided, **COULD** result in **MINOR** or **MODERATE INJURY**.

NOTICE

Addresses practices not related to personal injury.

Potential hazards associated with the operation of this equipment will be referenced with hazard symbols which may appear throughout this manual in conjunction with safety messages.

Symbol	Safety Hazard
	Lethal exhaust gas hazards
	Explosive fuel hazards
	Burn hazards
	Rotating parts hazards
	Hydraulic fluid hazards

SAFETY INFORMATION

GENERAL SAFETY

CAUTION

- **NEVER** operate this equipment without proper protective clothing, shatterproof glasses, respiratory protection, hearing protection, steel-toed boots and other protective devices required by the job or city and state regulations.



- Avoid wearing jewelry or loose fitting clothes that may snag on the controls or moving parts as this can cause serious injury.

- **NEVER** operate this equipment when not feeling well due to fatigue, illness or when under medication.



- **NEVER** operate this equipment under the influence of drugs or alcohol.



- **ALWAYS** clear the work area of any debris, tools, etc. that would constitute a hazard while the equipment is in operation.

- No one other than the operator is to be in the working area when the equipment is in operation.

- **DO NOT** use the equipment for any purpose other than its intended purposes or applications.

NOTICE

- This equipment should only be operated by trained and qualified personnel 18 years of age and older.
- Whenever necessary, replace nameplate, operation and safety decals when they become difficult read.
- Manufacturer does not assume responsibility for any accident due to equipment modifications. Unauthorized equipment modification will void all warranties.
- **NEVER** use accessories or attachments that are not recommended by Multiquip for this equipment. Damage to the equipment and/or injury to user may result.
- **ALWAYS** know the location of the nearest fire extinguisher.
- **ALWAYS** know the location of the nearest first aid kit.
- **ALWAYS** know the location of the nearest phone or **keep a phone on the job site**. Also, know the phone numbers of the nearest **ambulance, doctor and fire department**. This information will be invaluable in the case of an emergency.

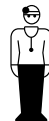

SAFETY INFORMATION

POWER BUGGY SAFETY

DANGER

- Engine fuel exhaust gases contain poisonous carbon monoxide. This gas is colorless and odorless, and can cause death if inhaled.
- The engine of this equipment requires an adequate free flow of cooling air. **NEVER** operate this equipment in any enclosed or narrow area where free flow of the air is restricted. If the air flow is restricted it will cause injury to people and property and serious damage to the equipment or engine.



- **NEVER** operate the equipment in an explosive atmosphere or near combustible materials. An explosion or fire could result causing severe **bodily harm or even death.**



WARNING

- **NEVER** use your hand to find hydraulic leaks. Use a piece of wood or cardboard. Hydraulic fluid injected into the skin must be treated by a knowledgeable physician immediately or severe injury or death can occur.
- Accidental starting can cause severe injury or death. **ALWAYS** place the ON/OFF switch in the OFF position.
- **NEVER** disconnect any **emergency or safety devices.** These devices are intended for operator safety. Disconnection of these devices can cause severe injury, bodily harm or even death. Disconnection of any of these devices will void all warranties.
- **NEVER** approach power lines with any part of the buggy unless all local, state/provincial and federal (OSHA) required safety precautions have been taken. Use extreme caution when approaching high voltage power lines.



CAUTION

- **ALWAYS** inspect the surface over which you will travel. Look for holes, drop-offs and obstacles. Look for rough and weak spots on docks, ramps or floor. Look for oil spills, wet spots and slippery surfaces. Look for soft soil, deep mud and standing water. Watch for anything that might make you lose control or cause the power buggy to tip over.
- **ALWAYS** clear away trash and debris. Pick up anything that might puncture the tires.
- **ALWAYS** make sure aisles, ramps, doorways and passages are clear.
- **ALWAYS** plan your work. Make sure you know where you will make your pickups, dumps and turns. Before you take a load, know where you will place it.
- **NEVER** operate the power buggy facing backwards. In a backwards position, the operator cannot properly activate the manual brake, emergency switch, grip the handles or steer the machine. **ALWAYS** face in the direction of the bucket.
- **DO NOT** operate the power buggy on unsafe haul roads, load areas, and dump areas.
- **DO NOT** operate power buggy on excessive slopes with a grade higher than 10% (6°), forward and backward or side to side.
- **DO NOT** operate power buggy on extremely uneven surfaces.
- **NEVER** allow riders other than the operator on the power buggy.
- **ALWAYS** secure the step plate (platform) in the upright position when using the power buggy over rough terrain.
- **DO NOT** stand on the power buggy step plate (platform) when walking in rough terrain. Walk behind the power buggy.
- **DO NOT** touch, lean on or reach through the dump mechanism or permit others to do so. **NEVER** climb on the power buggy or dump mechanism.

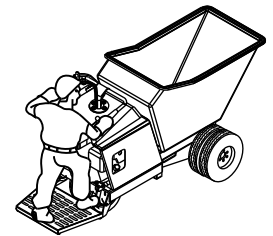



SAFETY INFORMATION

- **DO NOT** operate the power buggy at excessive speeds. Reckless operation may cause accidents and severe injury. Slow down when approaching people, wet areas, and going up and down grades. It is the responsibility of the operator to adjust speed, as necessary, depending on the conditions of the road or path.
 - **ALLOW** extra time to stop when operating the power buggy on wet surfaces or loosely graded materials.
 - **ONLY** remove the outer tires when it is necessary to reduce the width of the power buggy in order to access narrow work areas. If outer tires are removed, the power buggy must only be used on level, solid surfaces such as concrete, asphalt, or compacted stone to prevent the power buggy from tipping. The maximum load must also be reduced to 1000 lb.
 - **DO NOT** dump materials that are large and chunky. These types of material may shift causing the power buggy to tip and throw the operator off the machine. The power buggy is intended for dumping free-flowing and loose materials such as dry soil, slag, and wet concrete.
 - **DO NOT** dump materials from bucket while the power buggy is moving.
 - For walk behind operation, the operator platform must be stowed and locked in the up position. The speed should also be reduced to 3 mph or slower.
- NOTICE**
- **ALWAYS** ensure power buggy is **securely** placed on appropriate blocks or jackstands when performing maintenance requires elevation of the buggy.
 - **ALWAYS** make sure the power buggy's brakes are working properly. Check brake linkage and adjust as required. **NEVER** operate the power buggy with a defective braking system.
 - Ensure brakes are applied when leaving or when using on a slope.
 - When parking on a slope, position the power buggy at a right angle to a slope. Ensure that the parking brake is engaged and holds the power buggy safely in place when parking on a slope.
 - **ALWAYS** block the power buggy with appropriate blocks when leaving the power buggy parked on a slope.
 - To prevent unexpected loss of control, **DO NOT** start engine on a sloping surface.
 - Ensure that the speed control lever works freely and returns to the closed position. **DO NOT** start engine unless speed control linkage is working properly.
 - Make sure that the tires are inflated to the manufacturer's recommended tire pressure.
 - **NEVER** operate the power buggy with bad or worn tires. **ALWAYS** replace defective tires with new ones.
 - **ALWAYS** make sure the hydraulic dumping mechanism of the tub is working properly.
 - Avoid sudden stops and starts and changes in direction. Operate the controls smoothly. **DO NOT** jerk the steering or any other controls.
 - **NEVER** attempt to work the control except from the operator's position.
 - **NEVER** drive or tow the power buggy in traffic or on public roads.
 - **ALWAYS** keep the machine in proper running condition.
 - Fix damage to machine and replace any broken parts immediately.
 - The entire power buggy (tub, step plate, shroud, wheels, etc.) should be cleaned after every use. Make sure there is no buildup of concrete, grease, oil or debris on the machine.
 - **ALWAYS** store equipment properly when it is not being used. Equipment should be stored in a clean, dry location out of the reach of children and unauthorized personnel.

SAFETY INFORMATION

ENGINE SAFETY

⚠ WARNING

- **DO NOT** place hands or fingers inside engine compartment when engine is running. 
- **NEVER** operate the engine with heat shields or guards removed.
- Keep fingers, hands hair and clothing away from all moving parts to prevent injury. 
- **ALWAYS** shut down the engine before performing service or maintenance.
- **DO NOT** remove the engine oil drain plug while the engine is hot. Hot oil will gush out of the oil tank and severely scald any persons in the general area of the power buggy.

⚠ CAUTION

- **NEVER** touch the hot exhaust manifold, muffler or cylinder. Allow these parts to cool before servicing equipment. 
- Make certain the operator knows how to and is capable of turning the engine OFF in case of an emergency.

NOTICE

- **NEVER** run engine without an air filter or with a dirty air filter. Severe engine damage may occur. Service air filter frequently to prevent engine malfunction.
- **NEVER** tamper with the factory settings of the engine or engine governor. Damage to the engine or equipment can result if operating in speed ranges above the maximum allowable. 

FUEL SAFETY

⚠ DANGER

- **DO NOT** start the engine near spilled fuel or combustible fluids. Fuel is extremely flammable and its vapors can cause an explosion if ignited.
- **ALWAYS** refuel in a well-ventilated area, away from sparks and open flames.

- **ALWAYS** use extreme caution when working with flammable liquids.
- **DO NOT** fill the fuel tank while the engine is running or hot.
- **DO NOT** overfill tank, since spilled fuel could ignite if it comes into contact with hot engine parts or sparks from the ignition system.
- Store fuel in appropriate containers, in well-ventilated areas and away from sparks and flames.
- **NEVER** use fuel as a cleaning agent.
- **DO NOT** smoke around or near the equipment. Fire or explosion could result from fuel vapors or if fuel is spilled on a hot engine. 
- **DO NOT** leave the power buggy in the vicinity of ovens, furnaces or radiant heaters. Heat could raise the pressure of the fuel so that vented gas could ignite.

BATTERY SAFETY (ELECTRIC START ONLY)

⚠ DANGER

- **DO NOT** drop the battery. There is a possibility that the battery will explode.
- **DO NOT** expose the battery to open flames, sparks, cigarettes, etc. The battery contains combustible gases and liquids. If these gases and liquids come into contact with a flame or spark, an explosion could occur. 

⚠ WARNING

- **ALWAYS** wear safety glasses when handling the battery to avoid eye irritation. The battery contains acids that can cause injury to the eyes and skin. 
- Use well-insulated gloves when picking up the battery.
- **ALWAYS** keep the battery charged. If the battery is not charged, combustible gas will build up.
- **DO NOT** charge battery if frozen. Battery can explode. When frozen, warm the battery to at least 61°F (16°C).

SAFETY INFORMATION

- **ALWAYS** recharge the battery in a well-ventilated environment to avoid the risk of a dangerous concentration of combustible gases.

- If the battery liquid (dilute sulfuric acid) comes into contact with **clothing or skin**, rinse skin or clothing immediately with plenty of water.

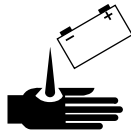

- If the battery liquid (dilute sulfuric acid) comes into contact with **eyes**, rinse eyes immediately with plenty of water and contact the nearest doctor or hospital to seek medical attention.

CAUTION

- **ALWAYS** disconnect the **NEGATIVE** battery terminal before performing service on the equipment.

- **ALWAYS** keep battery cables in good working condition. Repair or replace all worn cables.

LIFTING SAFETY

CAUTION

- **NEVER** allow any person or animal to stand underneath the equipment while lifting.

NOTICE

- When lifting of the power buggy is required, use a properly rated forklift. Forklift pockets are provided on the power buggy's frame. Make sure the forklift arms are insert into the power buggy's fork lift pockets a minimum of 24-inches. Before lifting, make sure that the lifting bale is not damaged.

- **NEVER** tip the engine to extreme angles during lifting as it may cause oil to gravitate into the cylinder head, making the engine start difficult.

- **DO NOT** lift machine to unnecessary heights.

- **NEVER** lift the equipment while the engine is running.

- **ALWAYS** use ramps capable of supporting the weight of the power buggy and the operator to load and unload the power buggy.

TRANSPORTING SAFETY

NOTICE

- **ALWAYS** shutdown engine before transporting.

- Tighten fuel tank cap securely and close fuel cock to prevent fuel from spilling.

- When transporting of the power buggy is required, place the power buggy on a flat bed truck or equivalent and tie down securely.

- **ALWAYS** make sure all tie-downs and block are in place and the bucket is completely lowered in the flat (horizontal) position and securely latched.

- Place **chock blocks** underneath wheel to prevent rolling.

- When transporting the power buggy on a truck or trailer, know the overall height to avoid contacting overhead obstructions such as bridges and power lines. Check the truck and ramp capacities.

ENVIRONMENTAL SAFETY

NOTICE

- Dispose of hazardous waste properly. Examples of potentially hazardous waste are used motor oil, fuel and fuel filters.

- **DO NOT** use food or plastic containers to dispose of hazardous waste.

- **DO NOT** pour waste, oil or fuel directly onto the ground, down a drain or into any water source.



Table 1. Specifications (Power Buggy)	
Models	WBH16/WBH16E
Wheelbase	44 in. (1,117.6 mm)
Overall Length	103 in. (2,616.2 mm)
Overall Width- Dual Wheels	43.25 in. (1,098.6 mm)
Maximum Weight Capacity (Dual Wheels)	30.25 in. (738.65 mm) 2,500 lbs. (1,136 kg)
Overall Width- Single Wheel	32 in. (813 mm)
Maximum Weight Capacity (Single Wheel)	1,100 lbs. (499 kg)
Overall Height	53 in. (1346.2 mm)
Operating Weight	1,200 lbs. (544.2 kg.)
Ship Weight Palletized	1,260 lbs. (585 kg.)
Bucket Capacity	16 cu. ft. Water Level (.59 cu. yd.)
Drive	Hydrostatic
Speed	Up to 7.25 mph. (11.67 km/h)
Steering	Handle Bars To Rear Wheels
Brakes (Drive Wheels)	Dynamic Hydrostatic
Parking Brake (Drive Wheels)	Mechanical
Dump Control	Hydraulic Dump and Return
Discharge Height	6.0 in. (152 mm)
Ground Clearance	6.0 in. (152 mm)
Turning Radius	73.5 in. (1867 mm)
Tires (Drive Wheels)	5.70 x 8.0 x 19.0 in. (145 x 203 x 483 mm)
Tires (Steering)	4.80 x 8.0 in. (122 x 203 mm)

SPECIFICATIONS

Table 2. Specifications (Engine)	
Model	GX390RT2QTT (Recoil Start) GX390RT2QNB2 (Electric Start)
Bore X Stroke	3.46 x 2.51 in. (88 x 64 mm.)
Displacement	389 cc
Maximum Power	11.7 hp (3,600 rpm)
Maximum Torque	19.5 ft-lbs. (2.7 kg-m) @ 2,500 rpm
Compression Ratio	8.0 : 1
Idle Speed	1,400 ± rpm
Maximum No Load RPM	3,850 ± rpm
Specific Fuel Consumption	1 gal./hr. (3.78 liters/hr.)
Fuel Tank Capacity	5.5 gal. (20.81 liters)
Crankcase Oil Capacity	1.16 qts. (1.1 liters)
Ignition Timing	BTDC25
Starting System	Recoil/Electric
Air Cleaner	Cyclone Type
Noise Level STD,OP	82.78 (S,S)
Dry Weight	68.3 lbs. (31.0 kg.)
Outside Dimensions L X W X H	15.9 x 17.7 x 17.4 (405 X 450 X 443 mm.)

DIMENSIONS

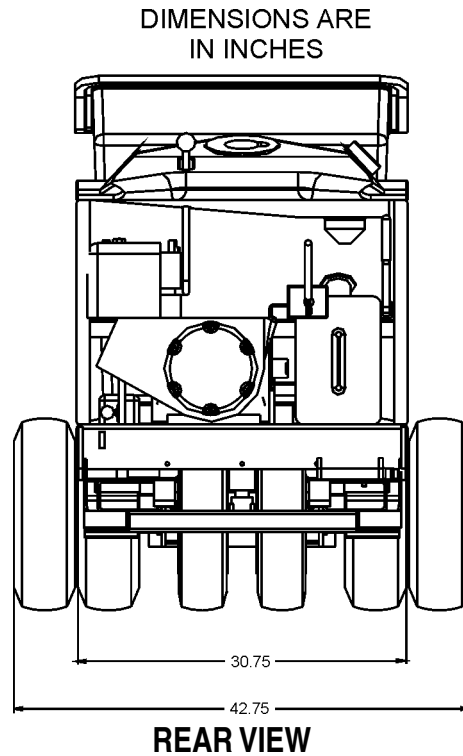
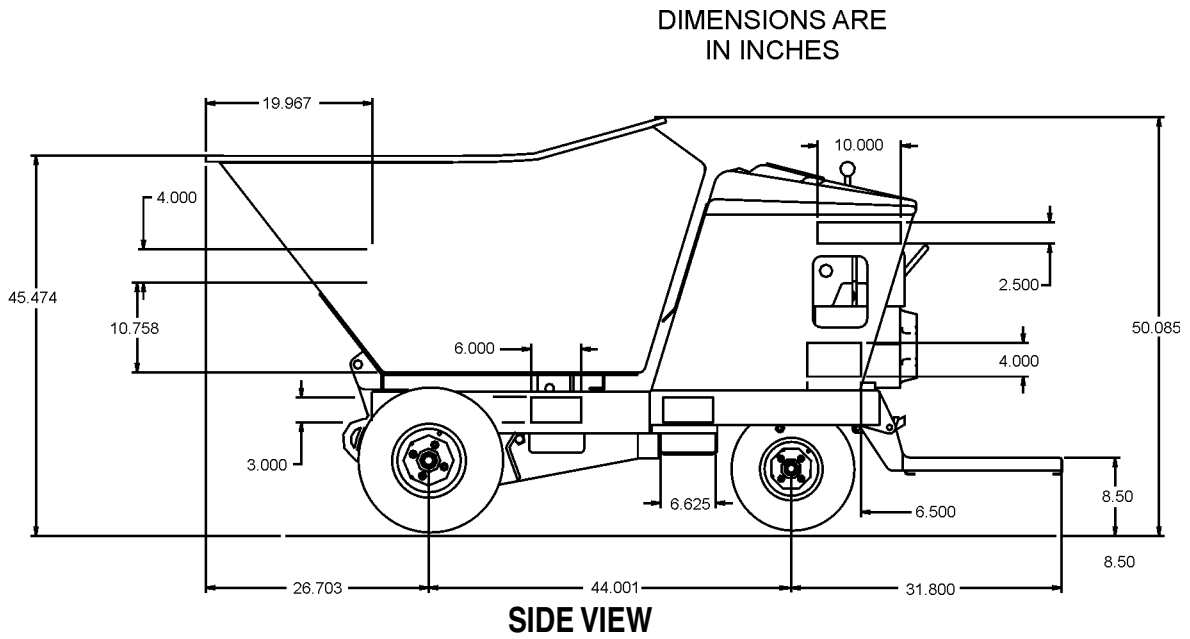

Figure 1. WBH16/WBH16E Dimensions

GENERAL INFORMATION

The MQ Whiteman Power Buggy, Models WBH16 (recoil start) and WBH16E (electric start) are intended for the transportation of concrete, concrete spreading and spot pouring. In addition, the WBH16/WBH16E is designed for landscaping applications, material sub-base distribution, job site cleanup and material transport.

The Power Buggy is equipped with a 6-inch dump height which provides clearance and enables the operator to maneuver over any form height. In addition, it has a unique polyethylene tub design that reduces concrete splatter.

A low center of gravity has been incorporated into the design which provides added safety when maneuvering the buggy in tight areas. A 5.5-gallon fuel tank allows for extended uninterrupted use. Maximum speed of the power buggy is rated at 7.25 MPH.

The maximum weight capacity of the Power Buggy is 2,500 lbs. (1,136 kg). The outer wheels can be removed to allow the buggy to pass through a 32 in. (81.28 cm.) door.

Hand and foot controls are provided for ease of dumping and stopping of the WBH16/WBH16E. Multiple lift points have been provided to allow for easy access of a forklift when lifting is required.

The WBH16/WBH16E is powered by a HONDA GX390 air cooled gasoline engine rated at 11.7 HP at 3600 RPM

The engine drives a variable displacement hydrostatic transmission which is activated by a cable controlled hand lever. The hydraulic fluid flows to a divider valve which directs the fluid to the forward reverse and dumping systems.

The operator controls the forward and reverse machine travel by manually shifting the control valve which directs the hydraulic fluid flow to the two drive wheel motors. The flow to the dump cylinder is also controlled by a manually operated control valve.

This hydraulic system uses a parallel loop configuration, operating at a maximum of 1450 PSI. The system also features a neutral position which allows the power buggy to be moved in the event of an emergency.

The hydraulic oil is filtered by a screen type filter located in the hydraulic tank, then doubled filtered within the system by a 10 micron cartridge spin-on return filter.

WARNING

All operators must have training before operating the WBH16/WBH16E. For your safety, warnings are on the machine and in this manual. Failure to obey these warnings can cause severe injury or even death.

CAUTION



DO NOT attempt to operate the power buggy until the Safety Information, General Information, and Inspection sections of this manual have been ***read and thoroughly understood.***

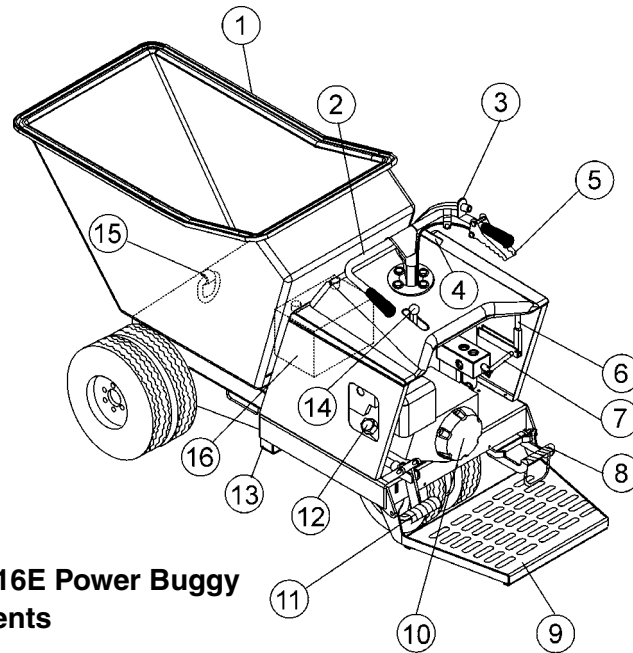

Figure 2. WBH16/WBH16E Power Buggy Components

1. **Tub or Bucket** — Used for the transportation of material. Tub holds approximately 16 cubic feet (0.59 cubic yards) of water.
2. **Handle Bar (Steering)** — This handle bar is used to steer the buggy. When driving the buggy, use both hands and hold onto both handle bar grips.
3. **Kill Switch** — In the event of an emergency, press this button to stop the engine.
4. **Fuel Tank/Cap** — Remove this cap to add fuel. Tank holds approximately 5.5 U.S. gallons. Do not over fill.
5. **Speed Control** — Sets the power buggy's travel speed. When fully depressed, the buggy will be at FULL speed. When released, the buggy will STOP.
6. **Parking Brake Lever** — When this lever is activated (pulled down), the parking brake will be set. To release the brake, pull the lever upwards.
7. **Travel Lever** — When the travel lever is pushed forward, the buggy will travel in the forward direction. Placing the travel lever in the backward position will cause the buggy to travel in the reverse direction. Center position is neutral.
8. **Brake Pedal** — Press this pedal with the right foot to stop the buggy.
9. **Operator Platform** — When the buggy is in use, the operator shall ALWAYS stand on this platform while holding onto the handle bar (steering).
10. **Engine** — The WBH16 uses a HONDA GX390RT2QTT (recoil start) engine. The WBH16E uses a HONDA GX390RT2QNB2 (electric start) engine.
11. **Dump Pedal** — Use this pedal to place the tub in the dump position (vertical). Press pedal a second time to return tub to the travel position (horizontal).
12. **Hydraulic Tank/Cap** — Remove this cap to add hydraulic oil. Tank holds approximately 6.0 U.S. gallons. DO NOT over fill.
13. **Forklift Pockets** — Use these fork lift pockets to lift the power buggy with a forklift. Remember to insert the forks of the fork lift a minimum of 24 inches into power buggy's fork lift pockets.
14. **Dump Control Lever** — Use this lever forward to place the tub in the dump position (vertical), move the lever backward to return the tub to travel position (horizontal).
15. **Towing Hook** — Use this hook to tow the buggy if it gets stuck. This hook is NOT intended for towing the buggy on public roads at high speeds.
16. **Battery** — Used in the electric-start power buggy (WBH16E) only. Always use gloves and eye protection when handling the battery.

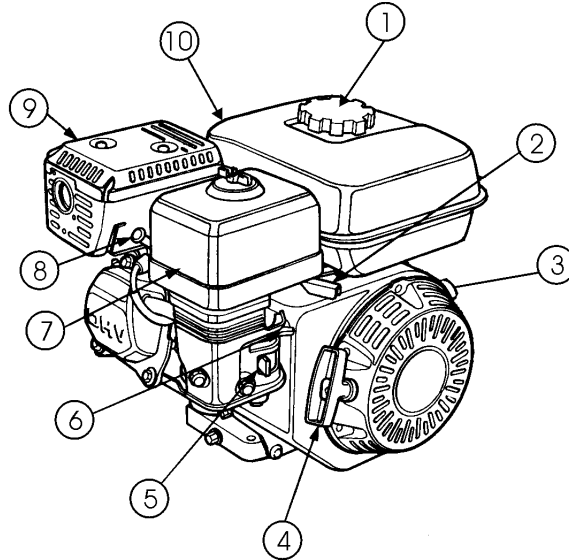

Figure 3. Honda GX390K1 Engine

1. **Fuel Filler Cap** — Remove this cap to add unleaded gasoline to the fuel tank. Make sure cap is tightened securely. DO NOT over fill.
2. **Throttle Lever** — Used to adjust engine RPM speed (lever advanced forward - SLOW, lever back toward operator - FAST).
3. **Engine ON/OFF Switch** — ON position permits engine starting, OFF position stops engine operation.
4. **Recoil Starter (pull rope)** — Manual-starting method. Pull the starter grip until resistance is felt, then pull briskly and smoothly.
5. **Fuel Valve Lever** — OPEN to let fuel flow, CLOSE to stop the flow of fuel.
6. **Choke Lever** — Used in the starting of a cold engine, or in cold weather conditions. The choke enriches the fuel mixture.
7. **Air Filter** — Prevents dirt and other debris from entering the fuel system. Release the latches on the sides of the air filter cover to gain access to filter element.
8. **Spark Plugs** — Provides spark to the ignition system. Set spark plug gap to 0.70- 0.76 mm (0.028 - 0.030 in.) Clean spark plug once a week.
9. **Muffler** — Used to reduce noise and emissions.
10. **Fuel Tank** — Holds unleaded gasoline. For additional information, refer to engine owner's manual.

CAUTION



Engine components can generate extreme heat. To prevent burns, DO NOT touch these areas while the engine is running or immediately after operating. NEVER operate the engine with the muffler removed.

NOTICE

Operating the engine without an air filter or with a damaged or worn air filter will allow dirt to enter the engine causing rapid engine wear.

BEFORE STARTING

1. Read safety information at the beginning of manual.
2. Clean the machine, removing dirt and dust, particularly the engine cooling air inlet, carburetor and air cleaner.
3. Check the air filter for dirt and dust. If air filter is dirty, replace air filter with a new one.
4. Check carburetor for external dirt and dust. Clean with dry compressed air.
5. Check fastening nuts and bolts for tightness.

ENGINE OIL CHECK

1. To check the engine oil level, place the buggy on secure level ground with the engine stopped.
2. Remove the filler cap/dipstick from the engine oil filler hole (Figure 4) and wipe it clean.

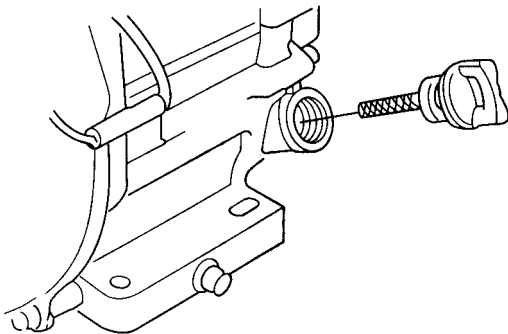

Figure 4. Engine Oil Dipstick Removal

3. Insert and remove the dipstick without screwing it into the filler neck. Check the oil level shown on the dipstick.
4. If the oil level is low (Figure 5), fill to the edge of the oil filler hole with the recommended oil type (Table 3). Maximum oil capacity is 400 cc.

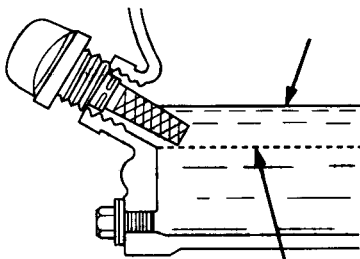

Figure 5. Oil Level

Table 3. Oil Type

Season	Temperature	Oil Type
Summer	25°C or Higher	SAE 10W-30
Spring/Fall	25°C~10°C	SAE 10W-30/20
Winter	0°C or Lower	SAE 10W-10

GASOLINE CHECK

DANGER



Motor fuels are highly flammable and can be dangerous if mishandled. **DO NOT** smoke while refueling. **DO NOT** attempt to refuel the pump if the engine is *hot or running*.

1. Remove the gasoline cap (Figure 6) located on top of fuel tank.

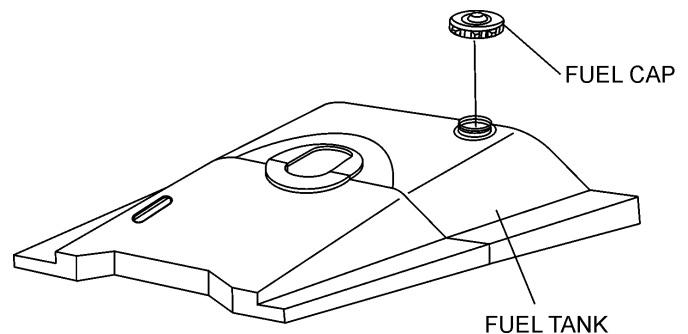

Figure 6. Fuel Tank

2. Visually inspect to see if fuel level is low. If fuel is low, replenish with unleaded fuel.
3. When refueling, be sure to use a strainer for filtration. Do not top-off fuel. Wipe up any spilled fuel.

TIRE PRESSURE CHECK

The wheels and tires of the WBH16/WBH16E are very important in its effective operation.

1. Check the tires regularly to make certain the lugs nuts are tight
2. Make sure tires are inflated to manufacturer's suggested tire pressure. Do not operate the buggy with bad or worn tires.

PARKING BRAKE CHECK

Check the brakes as outlined in the maintenance section of this manual.

LINKAGE CHECK

Check and make sure that all linkages within the buggy are functioning correctly.

STEERING CHECK

1. Check and make sure that the power buggy's steering turns freely and that there is no binding.
2. Make sure that the zerk fitting for the steering has been lubricated.

DUMP CYLINDER CHECK

1. Check the power buggy's dump cylinder as outlined in the operation section of this manual.
2. Make sure that both zerk fittings for the dump cylinder have been lubricated.

HYDRAULIC OIL CHECK

3. Visually read the hydraulic sight glass (Figure 7) to see if the hydraulic oil level is low.
4. If the hydraulic oil is low, add enough hydraulic oil to bring oil level to a normal safe operating level.

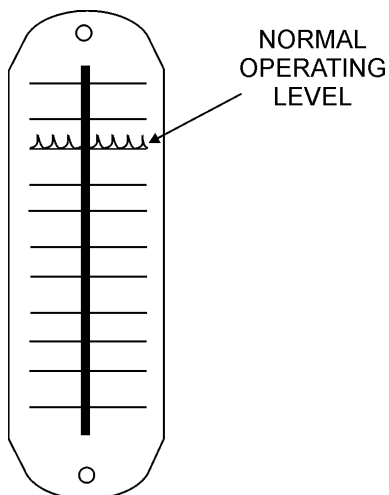

Figure 7. Hydraulic Sight Glass

CAUTION



DO NOT attempt to operate the power buggy until the Safety Information, General Information, and Inspection sections of this manual have been **read and thoroughly understood**.

ELECTRIC START (WBH16E ONLY)

1. Before attempting to start the power buggy, make sure that the safety kill switch (Figure 19) is not pushed in. The power buggy will not start with the kill switch engaged.
2. Place the engine fuel lever to the ON position. (Figure 8).

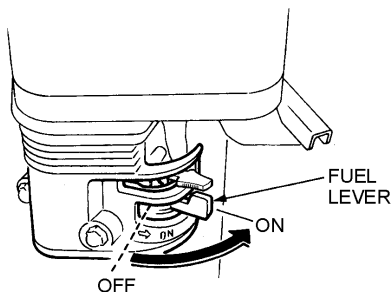

Figure 8. Engine Fuel Lever (ON Position)

3. Place the choke lever (Figure 9) in the CLOSED position if starting a cold engine.

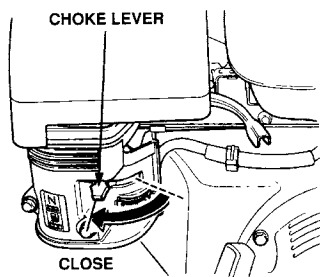

Figure 9. Engine Choke Lever (Closed)

NOTICE

The CLOSED position of the choke lever enriches the fuel mixture for starting a cold engine. The OPEN position provides the correct fuel mixture for normal operation after starting, and for restarting a warm engine.

4. Place the choke lever (Figure 10) in the OPEN position if starting a warm engine or the temperature is warm.

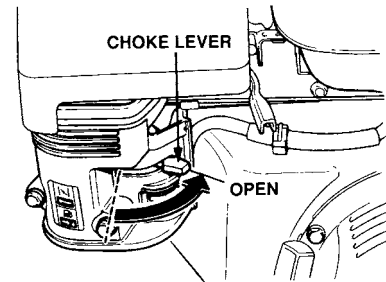

Figure 10. Engine Choke Lever (Open)

5. Move the throttle lever halfway between the FAST and SLOW position (Figure 11) for starting.

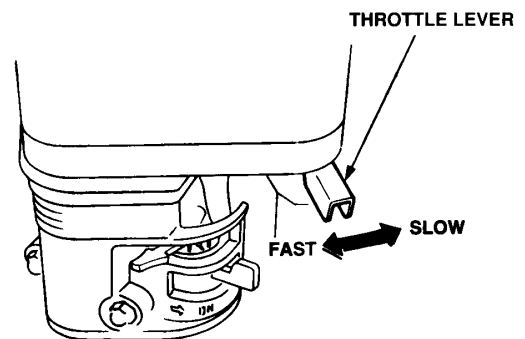

Figure 11. Throttle Lever

6. Turn the engine ON/OFF switch (Figure 12) to the START position and hold it until the engine starts. When engine starts, release the key, allowing it to return to the ON position.

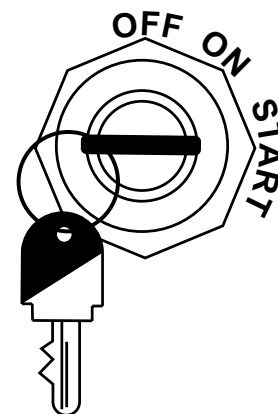

Figure 12. Engine ON/OFF Switch (Electric Start)

7. Make sure the choke lever is in the OPEN position (Figure 10) before operating the power buggy. Before the buggy is placed into operation, run the engine for several minutes. Check for fuel leaks, and noises that would associate with a loose guard or cover.

RECOIL START

1. Follow steps 1 through 5 of the Electric Start procedure.
2. Place the Engine ON/OFF switch (Figure 13) in the ON position.

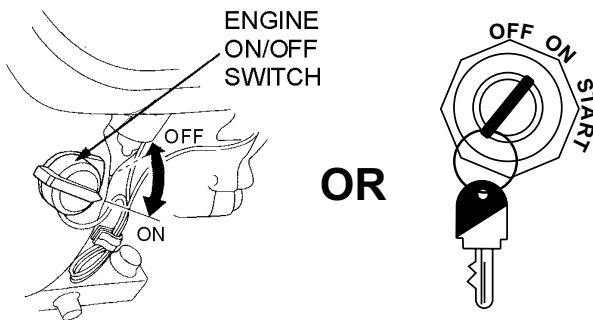

Figure 13. Engine ON/OFF Switch (Recoil Start)

3. Grasp the starter grip (Figure 14) and slowly pull it out. The resistance becomes the hardest at a certain position, corresponding to the compression point. Pull the starter grip briskly and smoothly for starting.

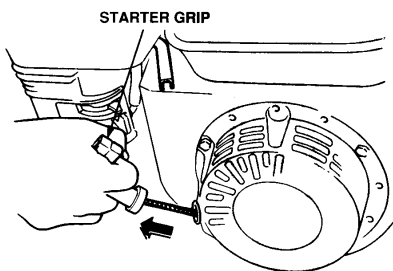

Figure 14. Starter Grip

NOTICE

DO NOT pull the starter rope all the way to the end.
DO NOT release the starter rope after pulling. Allow it to rewind as soon as possible.

4. If the engine has started, slowly push the choke lever inward to the RUN position. If the engine has not started, repeat steps 1 through 3.

PRE-CHECK

1. Engage the parking brake lever (Figure 15) and attempt to rock the buggy back and forth. If the wheels turn during the rocking motion, adjust the brakes as outlined in the maintenance section of this manual.

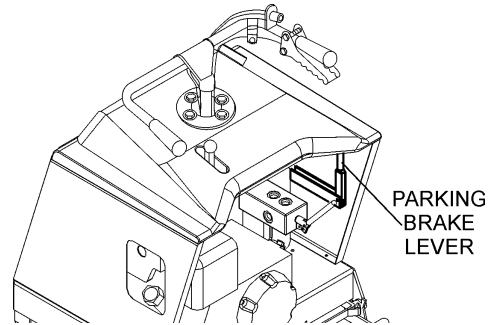

Figure 15. Parking Brake Lever

2. Place the engine's throttle lever (Figure 11) in the slow (idle) position.
3. Check the speed control lever (Figure 16) located on the right side of the handle bar. The speed control should work freely when squeezed by hand, and return to the closed position when released.

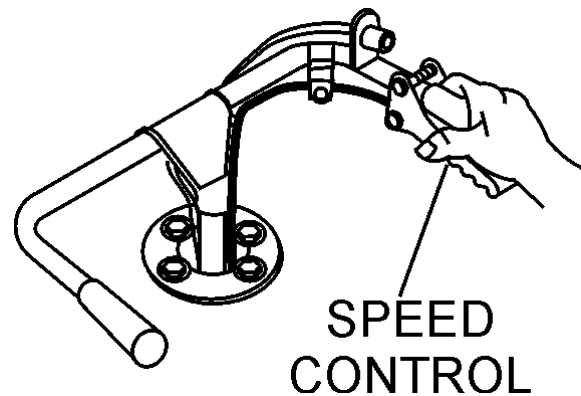

Figure 16. Speed Control Lever

PARKING BRAKE/DIRECTION LEVER

Before the power buggy can be put into operational use, it is best to perform a test run to make certain that all components are functioning properly.

1. Place the buggy on flat solid ground.
2. Engage the parking brake lever.
3. Place the engine's throttle control (Figure 11) in the SLOW (idle) position.
4. Place the power buggy's direction lever (Figure 17) in the forward direction.

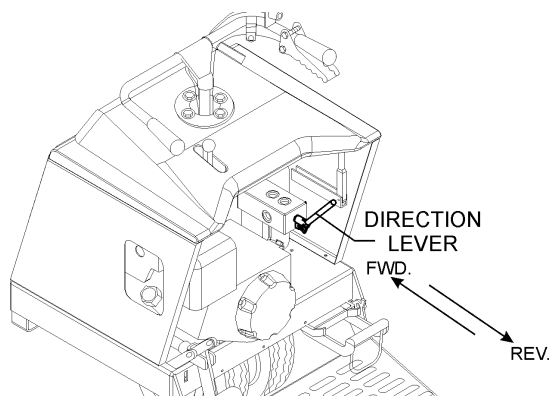

Figure 17. Direction Lever

5. Slowly squeeze the speed control lever slightly (Figure 16), for a short period of time to test the brake holding capacity. If the buggy moves forward, adjust the brakes as outlined in the maintenance section of this manual.
6. If the buggy does not move forward, release the speed control, and disengage the parking brake. If the buggy creeps forward or reverse while the parking brake is disengaged, the machine will require service adjustment of the pump control lever as outlined in the maintenance section of this manual.

TRAVELING

1. With the engine running and parking brake released, place the direction lever (Figure 17) in the forward direction.
2. Squeeze the speed control lever (Figure 16) slightly until the buggy begins to move in a forward direction. Initially, let the buggy travel at about 3 MPH.

3. When using the buggy for the first time, test the brake. With the right foot, step up and place it on the brake pedal (Figure 18). Gradually apply pressure to the brake pedal until the buggy comes to rest.

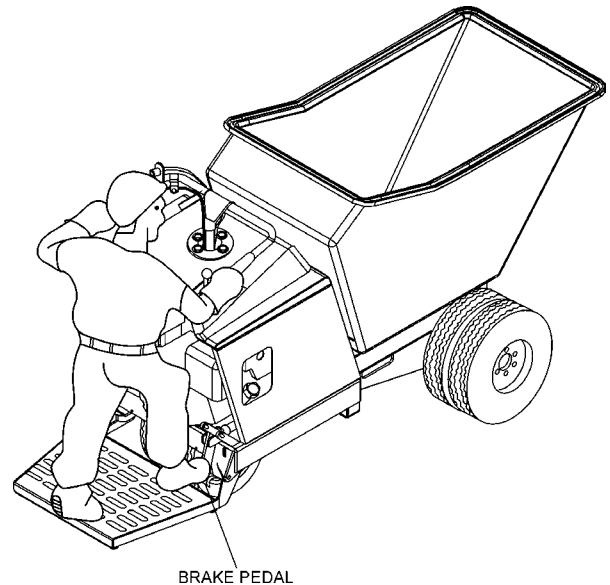

Figure 18. Brake Pedal

4. Test the brake at different speeds until you are comfortable with stopping the buggy. If the brakes do not seem to stop the buggy adequately, refer to the maintenance section of this manual for brake adjustment instructions.
5. When starting and stopping is confirmed to be functioning properly, the buggy is ready for operation.

SHUTDOWN (NORMAL)

Correct shutdown is important to safe operation. Follow these general steps:

1. Come to a full stop.
2. Engage the parking brake (Figure 15).
3. Place the throttle lever (Figure 11) in the slow position. Idle engine 3-5 minutes for gradual cooling.
4. Turn the engine on/off switch (Figure 12 or Figure 13) to the OFF position to shut down the engine.
5. Cycle hydraulic controls to eliminate residual pressure.
6. Remove ignition key on electric start models.
7. Block wheels if on a slope or incline.

EMERGENCY SHUTDOWN

The WBH16/WBH16E is equipped with a safety kill switch. This switch is located on the right side of the handle bar.

1. Press the power buggy's kill switch (Figure 19) and listen for the engine to stop.

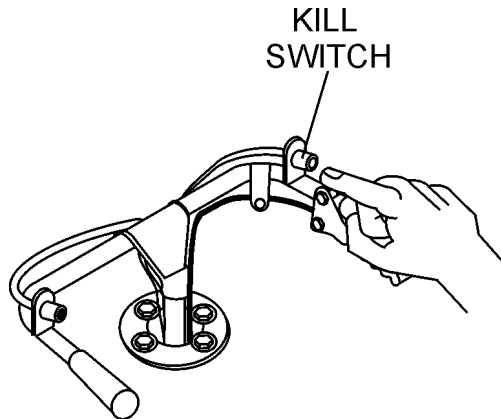

Figure 19. Safety Kill Switch

2. Engage the parking brake (Figure 15).
3. Turn the ignition switch (Figure 12) to the OFF position.

STEERING

To steer the buggy, use the handle bar in front of the operator platform.

1. To turn left when traveling in the forward direction, turn the handle bar clockwise (Figure 20).

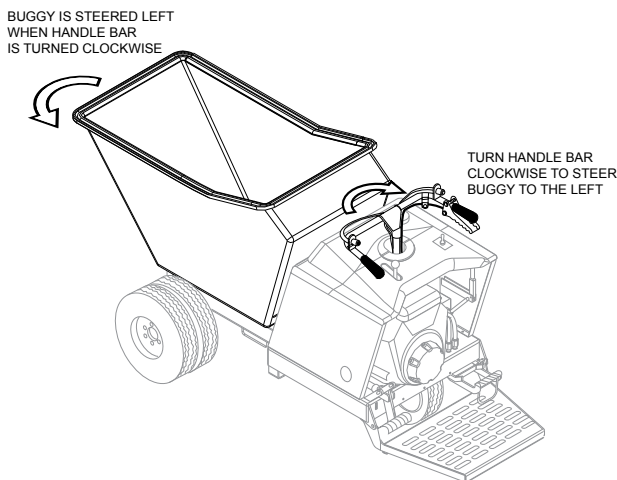

Figure 20. Steering the Buggy

2. To turn right when traveling in the forward direction, turn the handle bar in the counterclockwise direction.

CAUTION

DO NOT steer the buggy left or right when traveling up or down on a grade. Travel in a straight path.

CAUTION

Avoid sudden and quick turns. When steering, turn the handle bar slowly. Always face the controls when traveling.

TRAVELING ON A SLOPE

1. When traveling on a slope, it is necessary to determine the grade of the path. The WBH16/WBH16E can travel up, down or side to side on a maximum grade of 10% (6°). Do not travel on steeper slopes.

To determine the % grade of your path of travel, use the formula and graph in Figure 21.

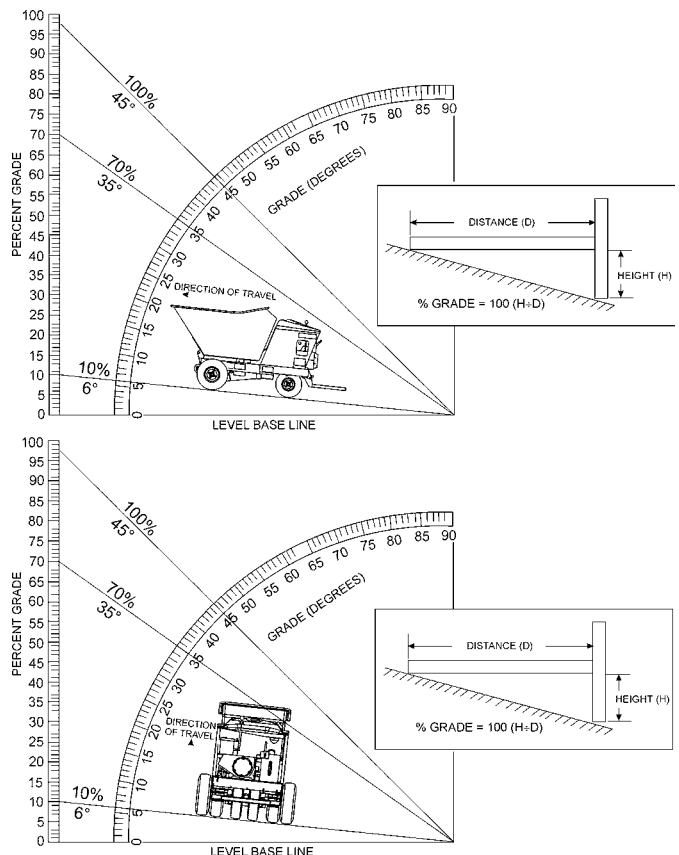

Figure 21. Determining Grade of Slope

2. When going up or down a slope, always travel in the forward direction (Figure 22).

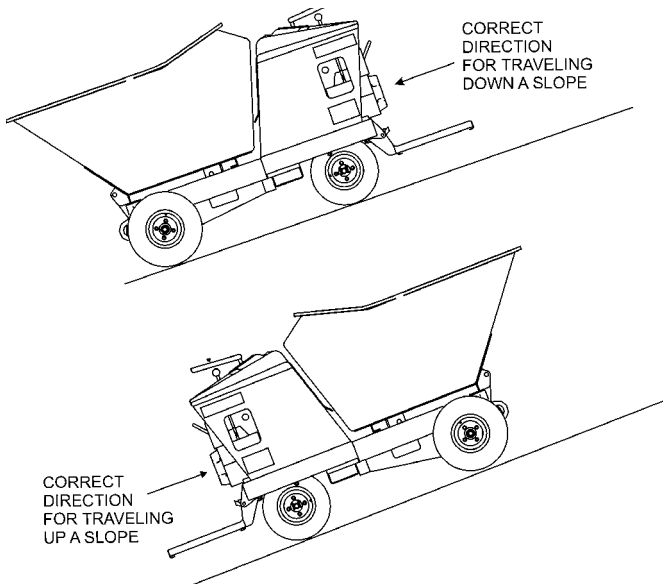

Figure 22. Slope Travel Direction

TUB (BUCKET) DUMPING

The hydraulic dump can be controlled by hand (dump control lever) or foot (dump pedal).

1. To activate the hydraulic dump, press down on the dump pedal (Figure 23) or move the dump control lever forward. The tub will move to the vertical position as long as pressure is continuously applied to the dump pedal or the dump control lever is held in the forward position.

NOTICE

Releasing either one (dump control lever or pedal) before dump is completed, will cause the tub to return to the horizontal position.

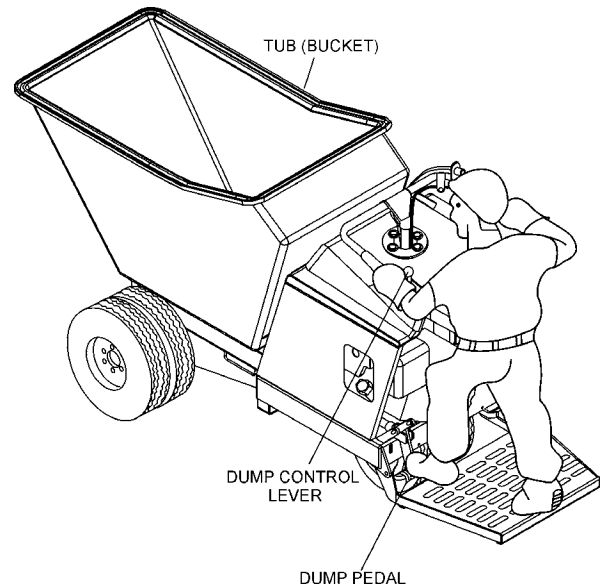

Figure 23. Dump Pedal

2. To return the tub to its horizontal position, simply release the dump control lever or remove your foot from the dump pedal.

ENGINE

Refer to the Honda engine owner's manual for specific information.

1. Check engine oil after every 10 hours of operation and maintain proper levels.
2. Drain oil after every 50 hours of operation and refill with grade of oil recommended below:

Above 40 °F. (13 °C.) - S.A.E. 30

Below 40 °F. (13 °C.) - S.A.E. 20

ADDING HYDRAULIC OIL

1. Check the hydraulic oil level in the hydraulic oil tank, by reading the hydraulic oil sight glass mounted on the hydraulic oil tank.
2. If the hydraulic oil level is low, fill to the proper level with MOBIL 300, GM DEXTRON B, FORD M2C-33F, FORD M2C41A hydraulic oil or equivalent.
3. To gain access to the hydraulic oil filler hole (Figure 24), the tub (bucket) must be put in the dump position (vertical). Start the engine as outlined in the starting procedure, then place the tub in the dumping position.

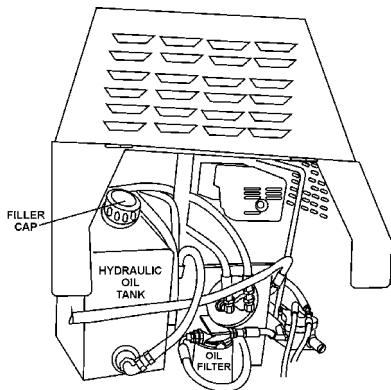

Figure 24. Hydraulic Oil Tank Filler Cap

4. Use the tub support rod to support the tub, then turn the engine OFF. Remove the hydraulic oil filler cap, and add hydraulic oil as required. Fill to the normal operating mark as indicated on the hydraulic oil sight gauge.

NOTICE

In climates where temperatures are below 35°F, hard starting may occur. In these cases, the hydraulic oil should be switched to a thinner 15 weight hydraulic fluid.

5. Replace hydraulic oil after every 200 hours of operation. The hydraulic oil filter should be changed each time the hydraulic oil is changed.

HYDRAULIC DRIVE MOTORS

The hydraulic drive motors are extremely reliable and will not need maintenance or repair under normal conditions. Should any problems develop with the hydraulic drive motors, contact Multiquip's service department.

BRAKE ADJUSTMENT

Brake adjustment can be made on the brake linkage rod located on the right-side of the buggy.

1. Place the parking brake lever in the engaged position. The parking brake should be adjusted so that the buggy will not move.
2. Adjustment is provided by a knob at the end of the parking brake lever. To tighten, turn the knob counterclockwise.
3. Adjust the knob sufficiently tight so that when the parking brake lever is actuated, considerable pressure is required to place it in the over center or ON position.
4. With the parking brake engaged, the buggy should not move when the engine is started and the travel lever pushed forward.

CHASSIS LUBRICATION

The WBH16/WBH16E is equipped with zerk fittings. Lubricate these zerk fittings each day before operating the buggy.

1. Lubricate with high grade chassis lubricant at all lubricating points listed below:
 - Dump Cylinder Pivots - two zerk fittings
 - Tub Bearing Pivot Blocks (underside of tub)- four zerk fittings.
 - Steering Bearing Flange (Front side of handle bar) - One zerk fitting.
2. Remove rear wheel hubs and repack bearings after every 400 hours of operation.

PUMP CONTROL LEVER ADJUSTMENT

If the power buggy tends to creep in the forward or reverse direction after you release the speed control lever, the pump control lever requires adjustment.

- Place the machine's drive wheels on jacks or blocks free from ground contact.
- Locate the pump control lever adjusting bolt.
- Loosen the jam nut.
- Start the engine and place the buggy's directional control lever in the forward then reverse directions while observing for wheel movement.
- The pump lever has a very sensitive neutral position of about 1/32" to 1/16". If the wheels are creeping, turn the adjusting bolt in very slight increments. If wheels are creeping in reverse, turn the adjusting bolt counterclockwise. If wheels are creeping forward, turn the adjusting bolt clockwise.

TIRES/WHEELS/LUG NUTS

Tires and wheels are very important and critical components of the buggy. When specifying or replacing the wheels, it is important that the wheels, tires, and axle are properly matched.

CAUTION







DO NOT attempt to repair or modify a wheel. **DO NOT** install an inner tube to correct a leak through the rim. If the rim is cracked, the air pressure in the inner tube may cause pieces of the rim to explode (break-off) with great force and can cause serious eye or bodily injury.

TIRES WEAR/INFLATION

Tire inflation pressure is the most important factor in tire life.

- Check tire pressure when the tires are cold before operation.
- Do not bleed air from tires when they are hot.
- Check inflation pressure weekly during use to ensure the maximum tire life and tread wear.
- Refer to Table 4 (Tire Wear Troubleshooting) to pinpoint the causes and solutions of tire wear problems.

Table 4. Tire Wear Troubleshooting

WEAR PATTERN	CAUSE	SOLUTION
 Center Wear	Over Inflation	Adjust pressure to particular load per tire manufacturer.
 Edge Wear	Under Inflation	Adjust pressure to particular load per tire manufacturer.
 Side Wear	Loss of chamber or overloading.	Make sure load does not exceed axle rating. Align wheels.
 Toe Wear	Incorrect toe-in	Align wheels.
 Cupping	Out-of balance	Check bearing adjustment and balance tires.
 Flat Spots	Wheel lockup & tire skidding.	Avoid sudden stops when possible and adjust brakes.

LUG NUT TORQUE REQUIREMENTS

It is extremely important to apply and maintain proper wheel mounting torque on the trailer. Be sure to use only the fasteners matched to the cone angle of the wheel. Proper procedure for attachment of the wheels is as follows:

- Start all wheel lug nuts by hand.
- Torque all lug nuts in sequence. See Figure 25. **DO NOT** torque the wheel lug nuts all the way down. Tighten each lug nut in 3 separate passes as defined by Table 5.

Table 5. Tire Torque Requirements

Wheel Size	First Pass FT-LBS	Second Pass FT-LBS	Third Pass FT-LBS
480 x 8 in.	20-25	35-40	50-65

- After first road use, retorque all lug nuts in sequence (Figure 25). Check all wheel lug nuts periodically.

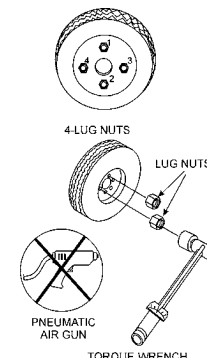

Figure 25. Lug Nut Torque Sequence

TROUBLESHOOTING

Troubleshooting (Power Buggy)		
Symptom	Possible Problem	Solution
Loss of Power.	Speed control cable out of adjustment?	Adjust speed control cable. Replace cable if necessary
	Hydraulic oil level low.?	Check hydraulic oil level. Add oil if necessary.
	Contaminated hydraulic oil filter?	Replace hydraulic oil filter.
	Low engine RPM?	Check engine speed.
Loss of Travel.	Forward/Reverse lever in neutral position?	Place lever in either forward or reverse position. Check hydraulic motors.
	Parking brake partially engaged?	Release parking brake.
System Operating Hot.	Hydraulic oil level low?	Check hydraulic oil level add hydraulic oil if necessary.
	Defective cooling fan?	Inspect cooling fan, replace if necessary.
Slow Dumping.	Low engine speed?	Check engine speed. Adjust engine speed if necessary.
	Dump cylinder is internally bypassing oil?	Replace dump cylinder.
System jerky when started.	Speed cable out of adjustment?	Adjust speed control cable.
	Defective drive motors?	Check drive motors, replace if necessary.
Difficult to steer.	Un-lubricated steering column?	Lubricate steering column.
Parking brake will not hold.	Brake linkage out of adjustment?	Use smaller diameter hose or replace hose.
Difficulty in stopping.	Brakes out of adjustment?	Brake lining worn. Replace brake lining.
Engine will not start.	Low on fuel or fuel tank empty?	Add fuel.
	Defective kill switch?	Check kill switch. Replace if necessary
	Engine ON/OFF switch in OFF position?	Set engine ON/OFF switch to ON position.
	Fuel Shut-off valve CLOSED?	Open Fuel shut-off valve.

TROUBLESHOOTING

Troubleshooting (Engine)		
Symptom	Possible Problem	Solution
Difficult to start, fuel is available, but no spark at spark plug.	Spark plug bridging?	Check gap, insulation or replace spark plug.
	Carbon deposit on spark plug?	Clean or replace spark plug.
	Short circuit due to deficient spark plug insulation?	Check spark plug insulation, replace if worn.
	Improper spark plug gap?	Set to proper gap.
	Fuel reaching carburetor?	Check fuel line.
	Water in fuel tank?	Flush or replace fuel tank.
	Fuel filter clogged?	Replace fuel filter.
	Stuck carburetor?	Check float mechanism.
	Spark plug is red?	Check transistor ignition unit.
	Spark plug is bluish white?	If insufficient compression, repair or replace engine. If injected air leaking, correct leak. If carburetor jets clogged, clean carburetor.
	No spark present at tip of spark plug?	Check transistor ignition unit is broken, and replace defective unit. Check if voltage cord cracked or broken and replace. Check if spark plug if fouled and replace.
	No oil?	Add oil as required.
	Oil pressure alarm lamp blinks upon starting? (if applicable)	Check automatic shutdown circuit, "oil sensor". (if applicable)
Difficult to start, fuel is available, and spark is present at the spark plug.	ON/OFF switch is shorted?	Check switch wiring, replace switch.
	Ignition coil defective?	Replace ignition coil.
	Improper spark gap, points dirty?	Set correct spark gap and clean points.
	Condenser insulation worn or short circuiting?	Replace condenser.
	Spark plug wire broken or short circuiting?	Replace defective spark plug wiring.
Difficult to start, fuel is available, spark is present and compression is normal.	Wrong fuel type?	Flush fuel system, and replace with correct type of fuel.
	Water or dust in fuel system?	Flush fuel system.
	Air cleaner dirty?	Clean or replace air cleaner.
	Choke open?	Close choke.
Difficult to start, fuel is available, spark is present and compression is low.	Suction/exhaust valve stuck or protruded?	Reseat valves.
	Piston ring and/or cylinder worn?	Replace piston rings and/or piston.
	Cylinder head and/or spark plug not tightened properly?	Torque cylinder head bolts and spark plug.
	Head gasket and/or spark plug gasket damaged?	Replace head and spark plug gaskets.
No fuel present at carburetor.	No fuel in fuel tank?	Fill with correct type of fuel.
	Fuel cock does not open properly?	Apply lubricant to loosen fuel cock lever, replace if necessary.
	Fuel filter/lines clogged?	Replace fuel filter.
	Fuel tank cap breather hole clogged?	Clean or replace fuel tank cap.
	Air in fuel line?	Bleed fuel line.

TROUBLESHOOTING

Troubleshooting (Engine) - continued		
Symptom	Possible Problem	Solution
Weak in power, compression is proper and does not misfire.	Air cleaner dirty?	Clean or replace air cleaner.
	Improper level in carburetor?	Check float adjustment, rebuild carburetor.
	Defective spark plug?	Clean or replace spark plug.
	Improper spark plug?	Set to proper gap.
Weak in power, compression is proper but misfires.	Water in fuel system?	Flush fuel system and replace with correct type of fuel.
	Dirty spark plug?	Clean or replace spark plug.
	Ignition coil defective?	Replace ignition coil.
Engine overheats.	Spark plug heat value incorrect?	Replace with correct type of spark plug.
	Wrong type of fuel?	Replace with correct type of fuel.
	Cooling fins dirty?	Clean cooling fins.
	Intake air restricted?	Clear intake of dirt and debris. Replace air cleaner elements as necessary.
	Oil level too low or too high?	Adjust oil to proper level.
Rotational speed fluctuates.	Governor adjusted incorrectly?	Adjust governor.
	Governor spring defective?	Replace governor spring.
	Fuel flow restricted?	Check entire fuel system for leaks or clogs.
Recoil starter malfunctions. (if applicable)	Recoil mechanism clogged with dust and dirt?	Clean recoil assembly with soap and water.
	Spiral spring loose?	Replace spiral spring.
Starter malfunctions.	Loose, damaged wiring?	Ensure tight, clean connections on battery and starter.
	Battery insufficiently charged?	Recharge or replace battery.
	Starter damaged or internally shorted?	Replace starter.
Burns too much fuel.	Over-accumulation of exhaust products?	Check and clean valves. Check muffler and replace if necessary.
	Wrong spark plug?	Replace spark plug with manufacturer's suggested type.
Exhaust color is continuously "white".	Lubricating oil is wrong viscosity?	Replace lubricating oil with correct viscosity.
	Worn rings?	Replace rings.
Exhaust color is continuously "black".	Air cleaner clogged?	Clean or replace air cleaner.
	Choke valve set to incorrect position?	Adjust choke valve to correct position.
	Carburetor defective, seal on carburetor broken?	Replace carburetor or seal.
	Poor carburetor adjustment, engine runs too rich?	Adjust carburetor.
Will not start, no power with key "ON". (if applicable)	ON/OFF device not activated ON?	Turn on ON/OFF device.
	Battery disconnected or discharged?	Check cable connections. Charge or replace battery.
	Ignition switch/wiring defective?	Replace ignition switch. Check wiring.

HYDRAULIC SYSTEM DIAGRAM

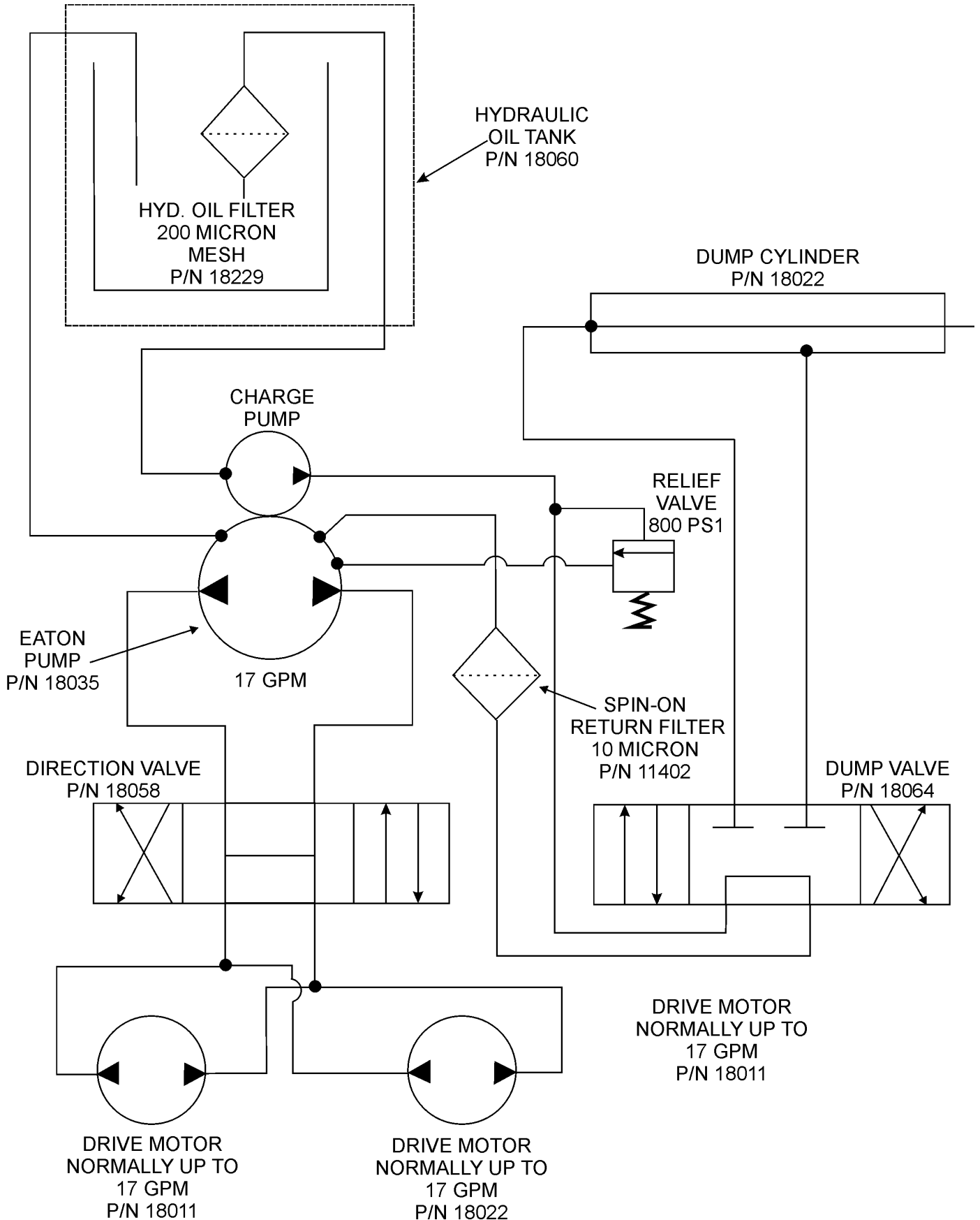

EXPLANATION OF CODE IN REMARKS COLUMN

The following section explains the different symbols and remarks used in the Parts section of this manual. Use the help numbers found on the back page of the manual if there are any questions.

NOTICE

The contents and part numbers listed in the parts section are subject to change **without notice**. Multiquip does not guarantee the availability of the parts listed.

SAMPLE PARTS LIST

NO.	PART NO.	PART NAME	QTY.	REMARKS
1	12345	BOLT	1	INCLUDES ITEMS W/%
2%		WASHER, 1/4 IN.		NOT SOLD SEPARATELY
2%	12347	WASHER, 3/8 IN. ...	1	MQ-45T ONLY
3	12348	HOSE	A/R	MAKE LOCALLY
4	12349	BEARING	1	S/N 2345B AND ABOVE

NO. Column

Unique Symbols — All items with same unique symbol

(@, #, +, %, or >) in the number column belong to the same assembly or kit, which is indicated by a note in the “Remarks” column.

Duplicate Item Numbers — Duplicate numbers indicate multiple part numbers, which are in effect for the same general item, such as different size saw blade guards in use or a part that has been updated on newer versions of the same machine.

NOTICE

When ordering a part that has more than one item number listed, check the remarks column for help in determining the proper part to order.

PART NO. Column

Numbers Used — Part numbers can be indicated by a number, a blank entry, or TBD.

TBD (To Be Determined) is generally used to show a part that has not been assigned a formal part number at the time of publication.

A blank entry generally indicates that the item is not sold separately or is not sold by Multiquip. Other entries will be clarified in the “Remarks” Column.

QTY. Column

Numbers Used — Item quantity can be indicated by a number, a blank entry, or A/R.

A/R (As Required) is generally used for hoses or other parts that are sold in bulk and cut to length.

A blank entry generally indicates that the item is not sold separately. Other entries will be clarified in the “Remarks” Column.

REMARKS Column

Some of the most common notes found in the “Remarks” Column are listed below. Other additional notes needed to describe the item can also be shown.

Assembly/Kit — All items on the parts list with the same unique symbol will be included when this item is purchased.

Indicated by:

“INCLUDES ITEMS W/(unique symbol)”

Serial Number Break — Used to list an effective serial number range where a particular part is used.

Indicated by:

“S/N XXXXX AND BELOW”

“S/N XXXX AND ABOVE”

“S/N XXXX TO S/N XXX”

Specific Model Number Use — Indicates that the part is used only with the specific model number or model number variant listed. It can also be used to show a part is NOT used on a specific model or model number variant.

Indicated by:

“XXXXX ONLY”

“NOT USED ON XXXX”

“Make/Obtain Locally” — Indicates that the part can be purchased at any hardware shop or made out of available items. Examples include battery cables, shims, and certain washers and nuts.

“Not Sold Separately” — Indicates that an item cannot be purchased as a separate item and is either part of an assembly/kit that can be purchased, or is not available for sale through Multiquip.

SUGGESTED SPARE PARTS

WBH16/WBH16E POWER BUGGY WITH HONDA GX390RT2QTT/GX390RT2QNB2 ENGINE

1 to 3 units

Qty.	P/N	Description
1	508667	FILTER, HYDRAULIC OIL
1	16477	CAP, HYDRAULIC OIL TANK
1	18035	PUMP, HYDROSTATIC
1	511719	COUPLING, ENGINE SHAFT
2	18316	LINING, BRAKE
1	18145	ROD, BRAKE CONTROL
1	520820	CAP, FUEL (EPA)
5	20763	FILTER, IN-LINE FUEL
1	18025	SWITCH, KILL
1	18133	CABLE, THROTTLE
1	18132	LEVER, THROTTLE
1	18029	WHEEL, DRIVE
1	18049	WHEEL, STEERING
1	18016	CABLE, PARKING BRAKE
3	9807955846	SPARK PLUG
3	11078	KEY, IGNITION (ELECTRIC START ONLY)
1	28462ZE3W01	ROPE (RECOIL START ONLY)
3	17210ZE3010	ELEMENT, AIR CLEANER

NOTICE

Part numbers on this Suggested Spare Parts list may supersede/replace the part numbers shown in the following parts lists.

NAMEPLATE AND DECALS

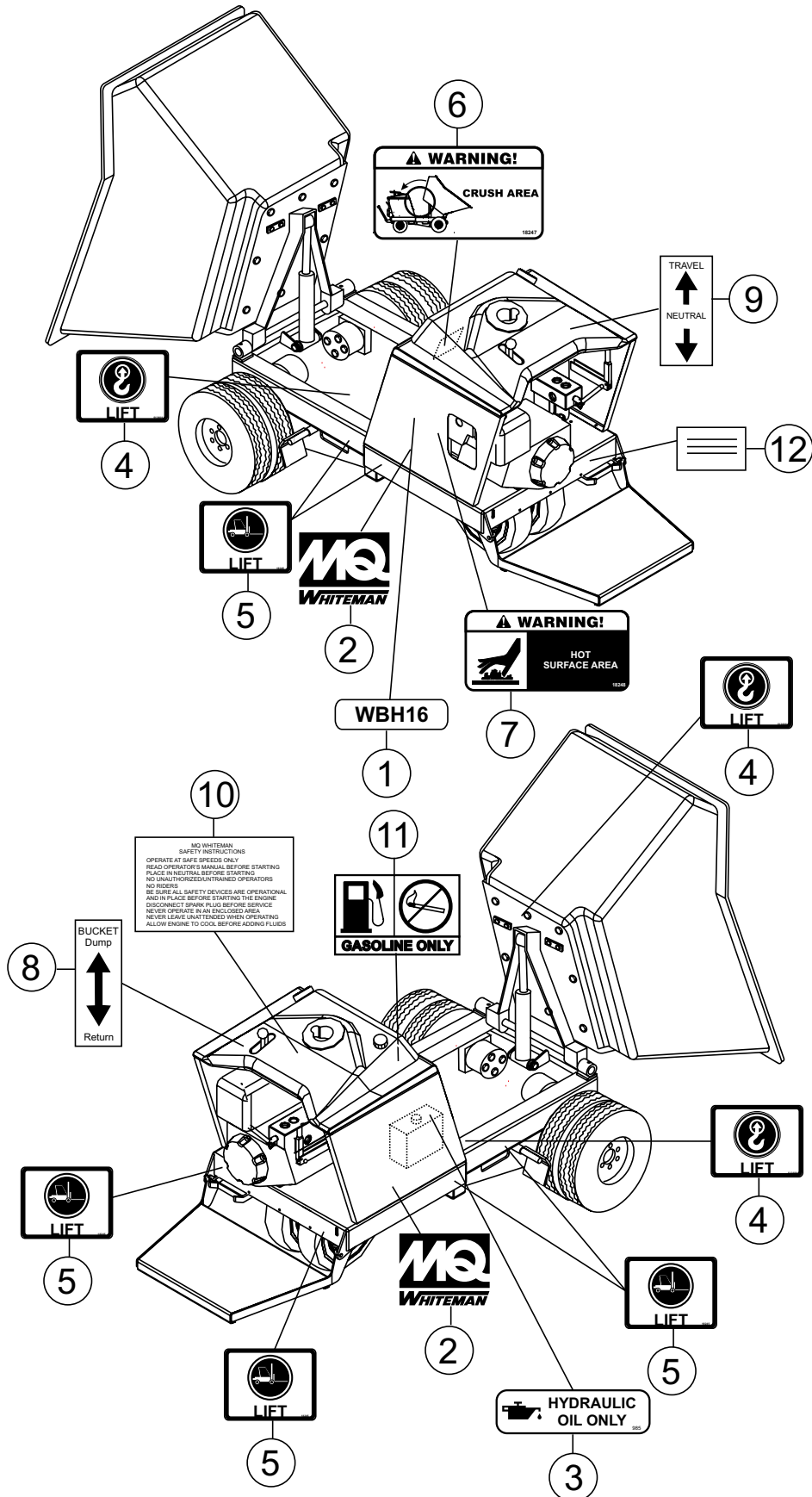

NAMEPLATE AND DECALS

<u>NO.</u>	<u>PART NO.</u>	<u>PART NAME</u>	<u>QTY.</u>	<u>REMARKS</u>
1	18252	DECAL, WBH16	2	
2	18251	DECAL, MQ WHITEMAN	2	
3	EM985	DECAL, HYDRAULIC OIL	1	
4	513608	DECAL, LIFTING HOOK	3	
5	18245	DECAL, FORKLIFT LIFTING	6	
6	18247	DECAL, CRUSH WARNING	1	
7	18248	DECAL, HOT SURFACE WARNING	1	
8		DECAL, BUCKET DUMP LEVER.....	1.....	NOT AVAILABLE*
9		DECAL, TRAVEL LEVER DIRECTION.....	1.....	NOT AVAILABLE*
10		DECAL, WHITEMAN SAFETY INSTRUCTIONS....	1.....	NOT AVAILABLE*
11		DECAL, GASOLINE ONLY	1.....	NOT AVAILABLE*
12		PLATE, SERIAL NUMBER.....	1.....	CONTACT MULTIQUIP PARTS DEPT.

* - Imprinted on plastic cover.

HYDRAULIC DRIVE ASSY.

VIEW FROM
OPERATOR'S
PLATFORM

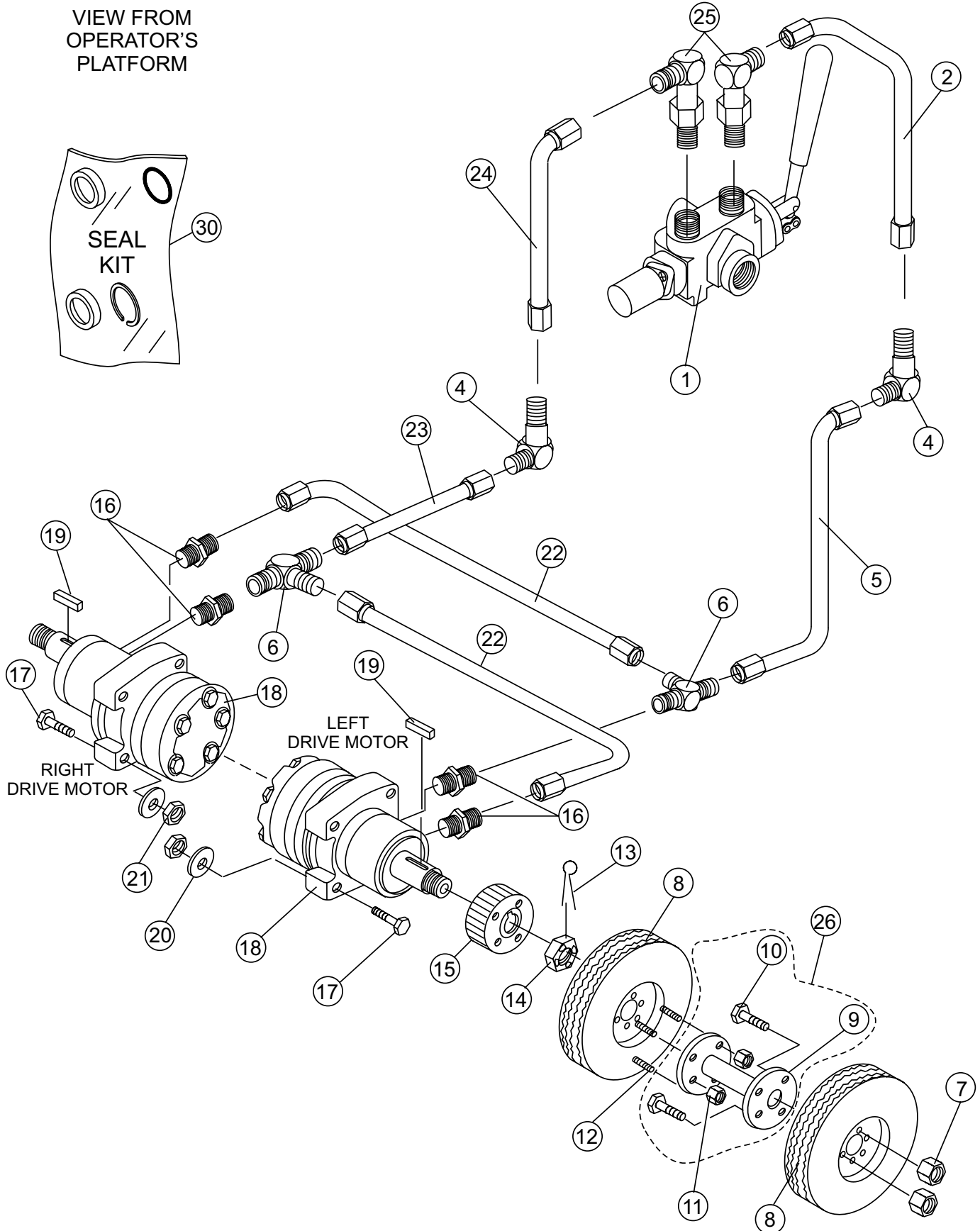

HYDRAULIC DRIVE ASSY.

<u>NO.</u>	<u>PART NO.</u>	<u>PART NAME</u>	<u>QTY.</u>	<u>REMARKS</u>
1	18058	VALVE, DIRECTION CONTROL	1	
2	18264M	HOSE, DIRECTION VALVE TO DRV. MOTOR	1	
4	511810	ADAPTER, ELBOW	2	
5	18276M	HOSE, LH HYDRAULIC MOTOR	1	
6	512189	ADAPTER, T - CONNECTOR	2	
7	492527	NUT, HEX 1/2-20	8	
8	18029	WHEEL, DRIVE ASSY. FRONT	4	
9*	511692	FLANGE, HUB	2	
10*	18237	LUG BOLT/HUB FLANGE	8	
11	492584	NUT, HEX 1/2-13 NYLON	8	REPLACES 6109160
12	18190	SCREW, HUB STUD 1/2-13X 3 IN.	8	
13	491689	KEY, COTTER 1/8 X 2	2	
14	PT018038	NUT, CASTLE 1-1/8-18	2	
15	18040	HUB, DRIVE	2	
16	3365	ADAPTER, STRAIGHT	6	
17	505718	SCREW, HHC 1/2-13 X 2-3/4	8	
18	18011	MOTOR, HYDRAULIC DRIVE	2	
19	PE449105	KEY, WOODRUFF 1-1/4 32 MM	2	
20	492600	WASHER, FLAT 1/2	8	
21	6109180	NUT, HEX 1/2" DIA	8	
22	18027	HOSE, DRIVER MOTOR CROSSOVER	2	
23	18275M	HOSE, RH HYDRAULIC MOTOR	1	
24	18265M	HOSE, DIRECTION VALVE TO DRIVE MOTOR	1	
25	3322	ADAPTER	2	
26	516528	FLANGE HUB ASSY.....	1	INCLUDES ITEMS W/ *
30	18011K	SEAL KIT, DRIVE MOTOR	1	

HYDRAULIC PUMP ASSY.

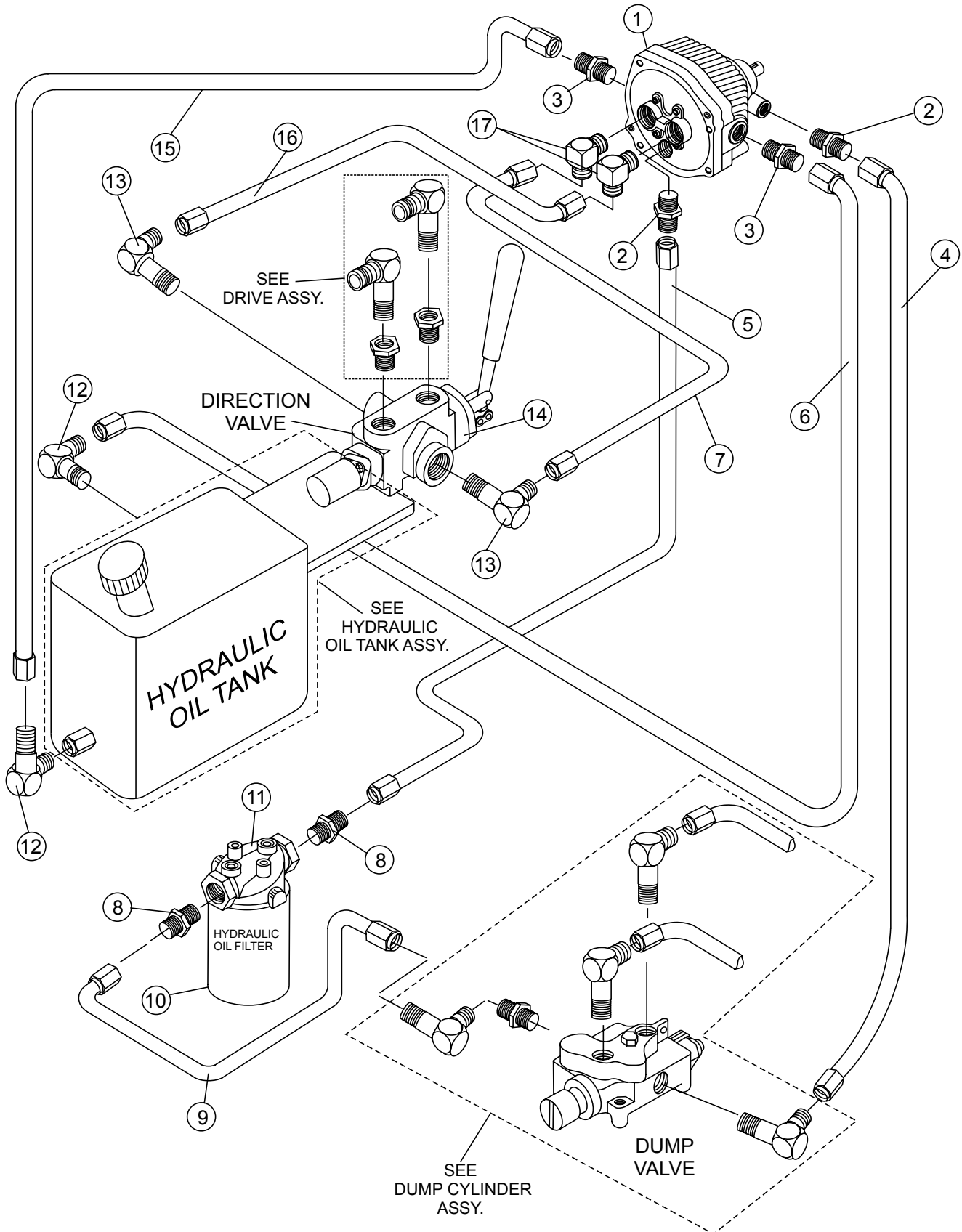

HYDRAULIC PUMP ASSY.

<u>NO.</u>	<u>PART NO.</u>	<u>PART NAME</u>	<u>QTY.</u>	<u>REMARKS</u>
1	18035	PUMP, HYDRAULIC	1	
2	511808	ADAPTER, STRAIGHT	2	
3	3365	ADAPTER, STRAIGHT	6	
4	18256M	HOSE, PUMP TO DUMP VALVE	1	
5	18258M	HOSE, FILTER TO PUMP	1	
6	18261M	HOSE, PUMP TO TANK	1	
7	18263M	HOSE, PUMP TO DIRECTION VALVE	1	
8	512190	ADAPTER, STRAIGHT	2	
9	18257M	HOSE, FILTER TO DUMP VALVE	1	
10	508667	FILTER	1	
11	508664	SUPPORT, FILTER	1	
12	511799	ADAPTER, ELBOW	2	
13	3322	ADAPTER, ELBOW	2	
14	18058	VALVE, DIRECTION CONTROL	1	
15	18262M	HOSE, TANK TO PUMP	1	
16	18266M	HOSE, PUMP TO DIRECTION VALVE	1	
17	3322	ADAPTER, ELBOW	2	

HYDRAULIC DUMP ASSY.

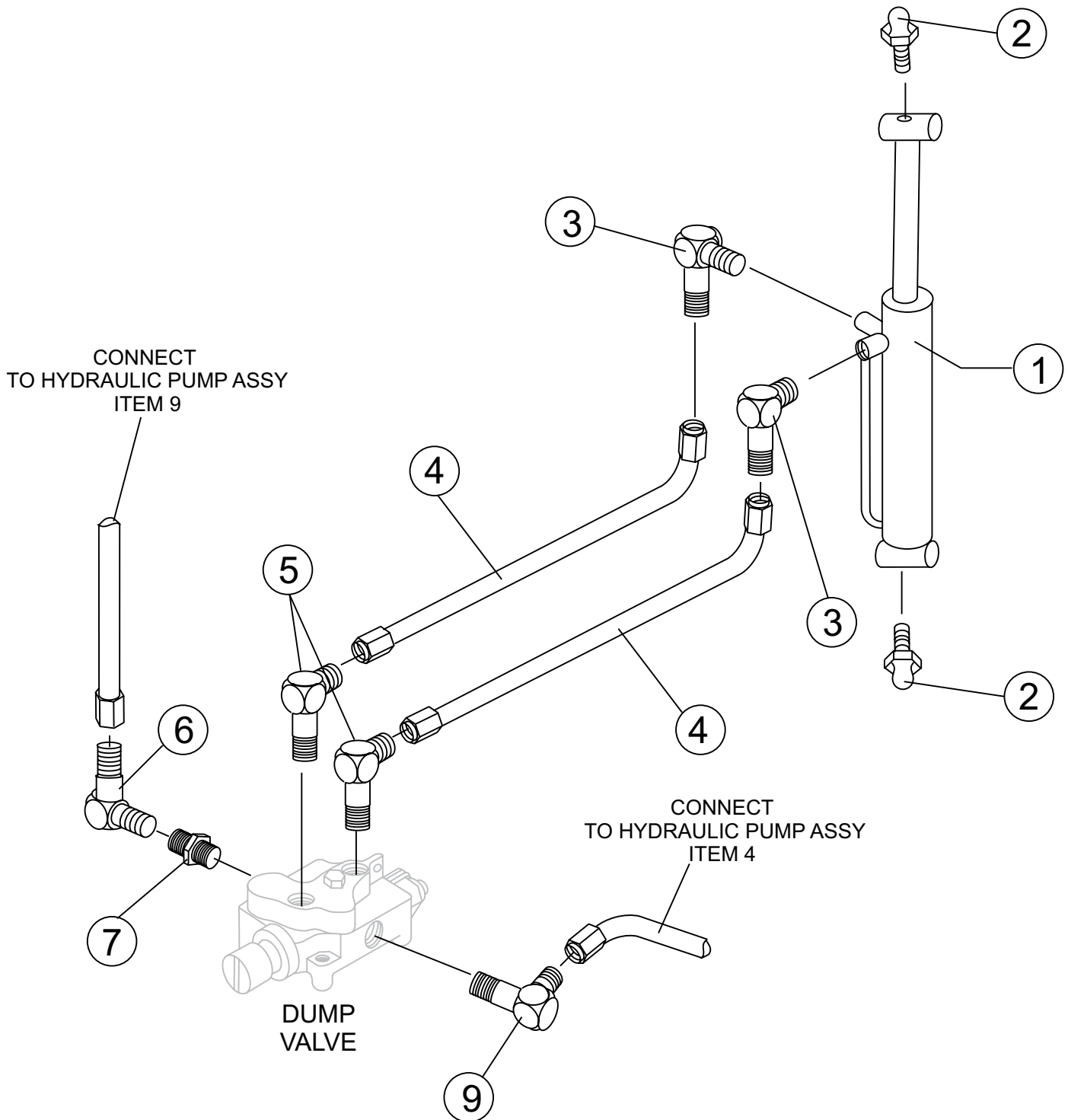

HYDRAULIC DUMP ASSY.

<u>NO.</u>	<u>PART NO.</u>	<u>PART NAME</u>	<u>QTY.</u>	<u>REMARKS</u>
1	18022	CYLINDER, HYDRAULIC DUMP	1	
2	491705	ZERK FITTING	2	
3	511803	ADAPTER, ELBOW	2	
4	18020	HOSE, DUMP VALVE TO HYD. PISTON	2	
5	511804	ADAPTER, STRAIGHT	2	
6	512234	ADAPTER, ELBOW	1	
7	511806	ADAPTER, STRAIGHT	1	
9	506191	ADAPTER, ELBOW	1	

PUMP AND COUPLING ASSY.

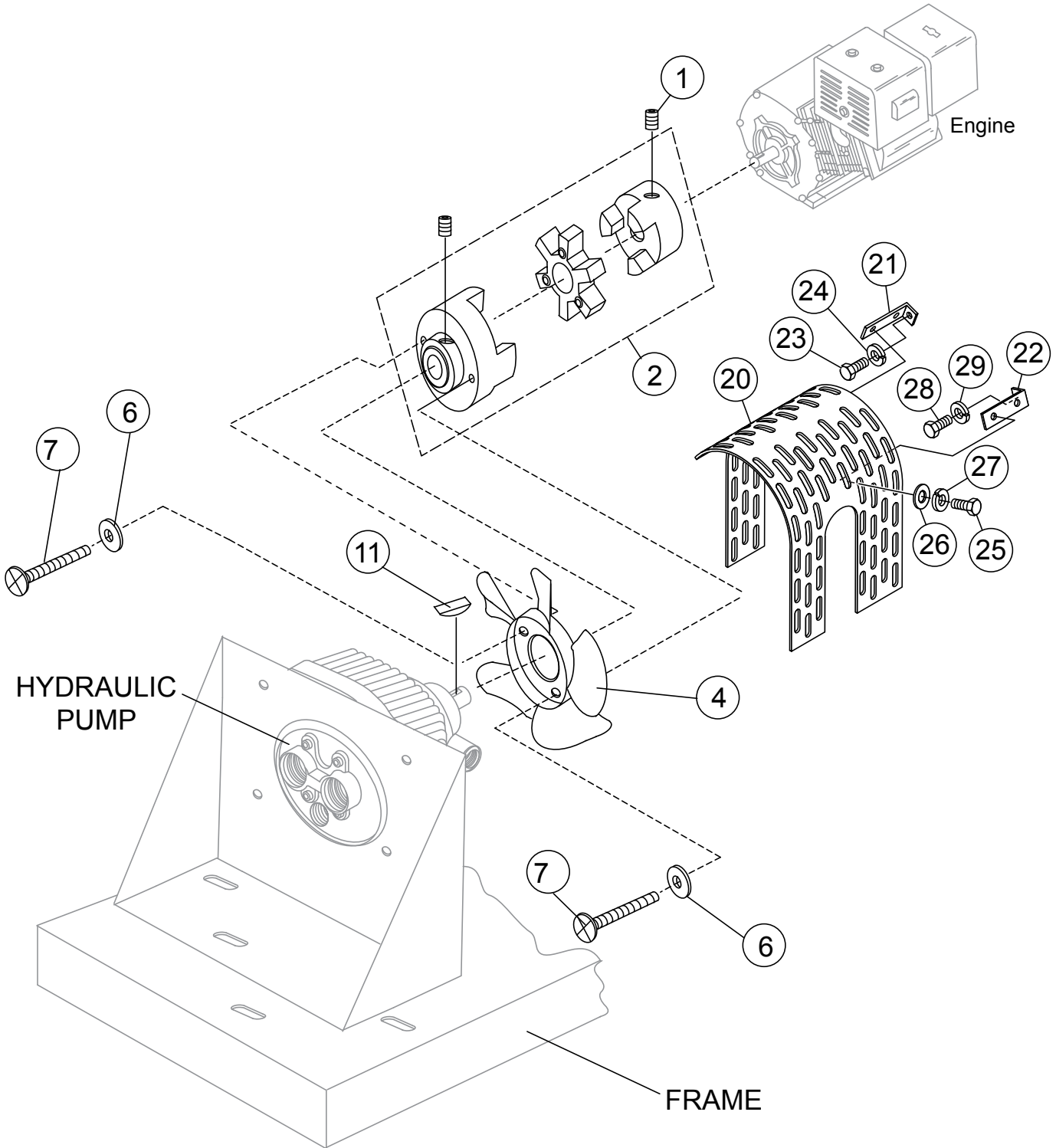

PUMP AND COUPLING ASSY.

<u>NO.</u>	<u>PART NO.</u>	<u>PART NAME</u>	<u>QTY.</u>	<u>REMARKS</u>
1	492472	SCREW, ALLEN HEAD 3/8-16 X 3/4	2	
2	511719	COUPLING, ENGINE SHAFT	1	
4	18112	FAN	1	
6	492596	WASHER, FLAT 1/4"	2	
7	492355	SCREW, HHC 1/4-20 X 1/2	2	
11	506250	KEY, WOODRUFF	1	
20	512494	FAN GUARD	1	
21	512493	BRACKET, LONG	1	
22	512505	BRACKET, SHORT	1	
23	492373	BOLT, C/H 3/8" NC X 3/4" G5	1	
24	492624	WASHER, LOCK 3/8 IN.	1	
25	512367	BOLT, C/H 3/16" NC X 1/2" G2	4	
26	492595	WASHER, FLAT 3/16 IN.	4	
27	492621	WASHER, LOCK 3/16 IN.	4	
28	492438	BOLT, C/H 5/16" NF X 1" G5	1	
29	492623	WASHER, LOCK 5/16"	1	

TUB ASSY.

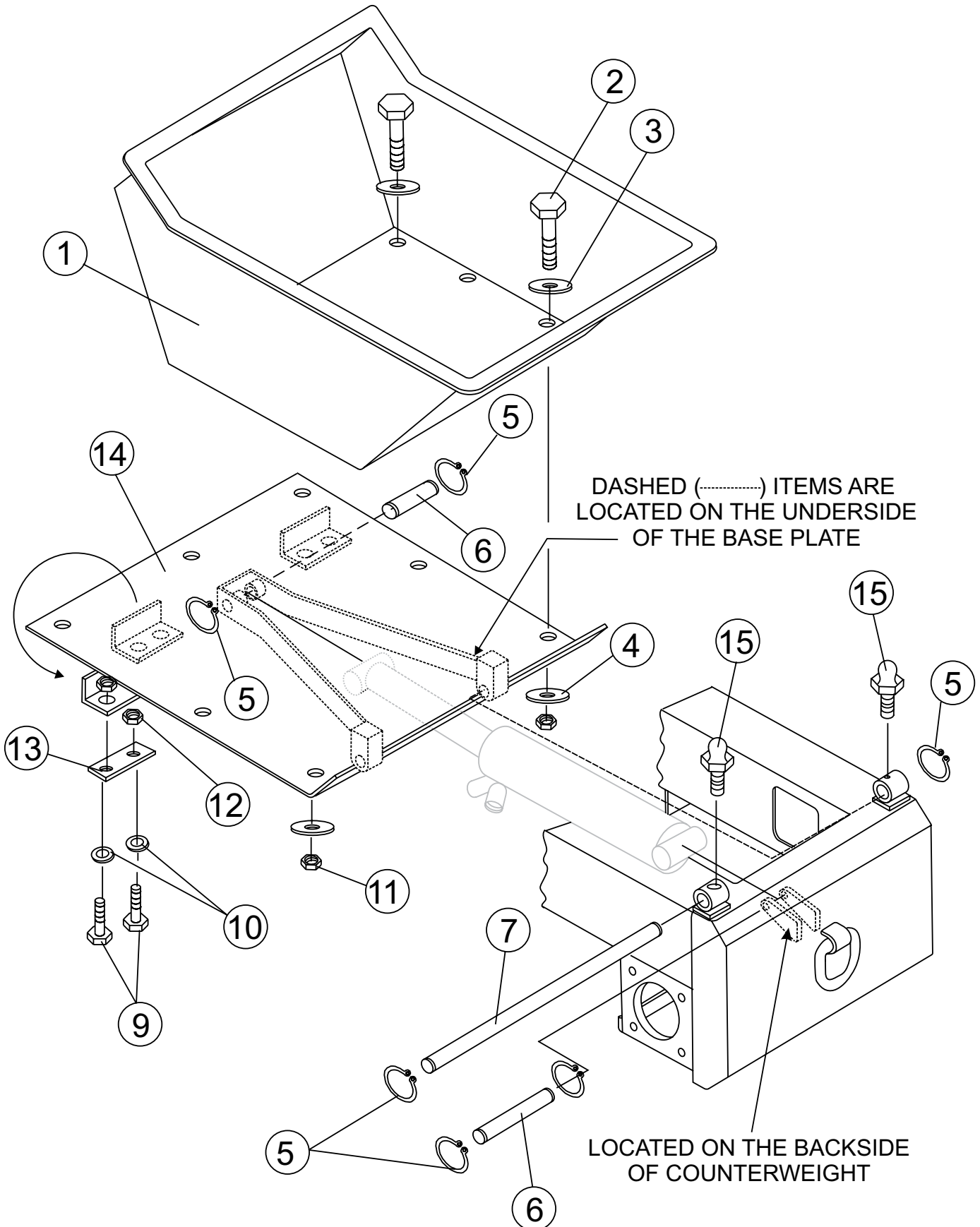

TUB ASSY.

<u>NO.</u>	<u>PART NO.</u>	<u>PART NAME</u>	<u>QTY.</u>	<u>REMARKS</u>
1	18004	TUB, PLASTIC	1	
2	492313	SCREW, HHC 3/8-16 X 1-1/2	9	
3	512193	WASHER, FLAT 3/8 LARGE	9	
4	492598	WASHER, FLAT 3/8	9	
5	490957	RING, SNAP	6	
6	18130	PIN, HYD. PISTON CROSS	2	
7	18129	PIN, TUB FRAME CROSS	1	
9	492365	SCREW, HHC 5/16-18 X 1-1/4	4	
10	492597	WASHER, FLAT 9.5 X 22.2	8	
11	492583	NUT, NYLOC 3/4-16	9	
12	492582	NUT, NYLOC 5/16-18	4	
13	512279	SUPPORT, BUM STOP	2	
14	18099	FRAME, TUB MOUNT	1	
15	491705	ZERK GREASE FITTING	2	

PANEL ASSY.

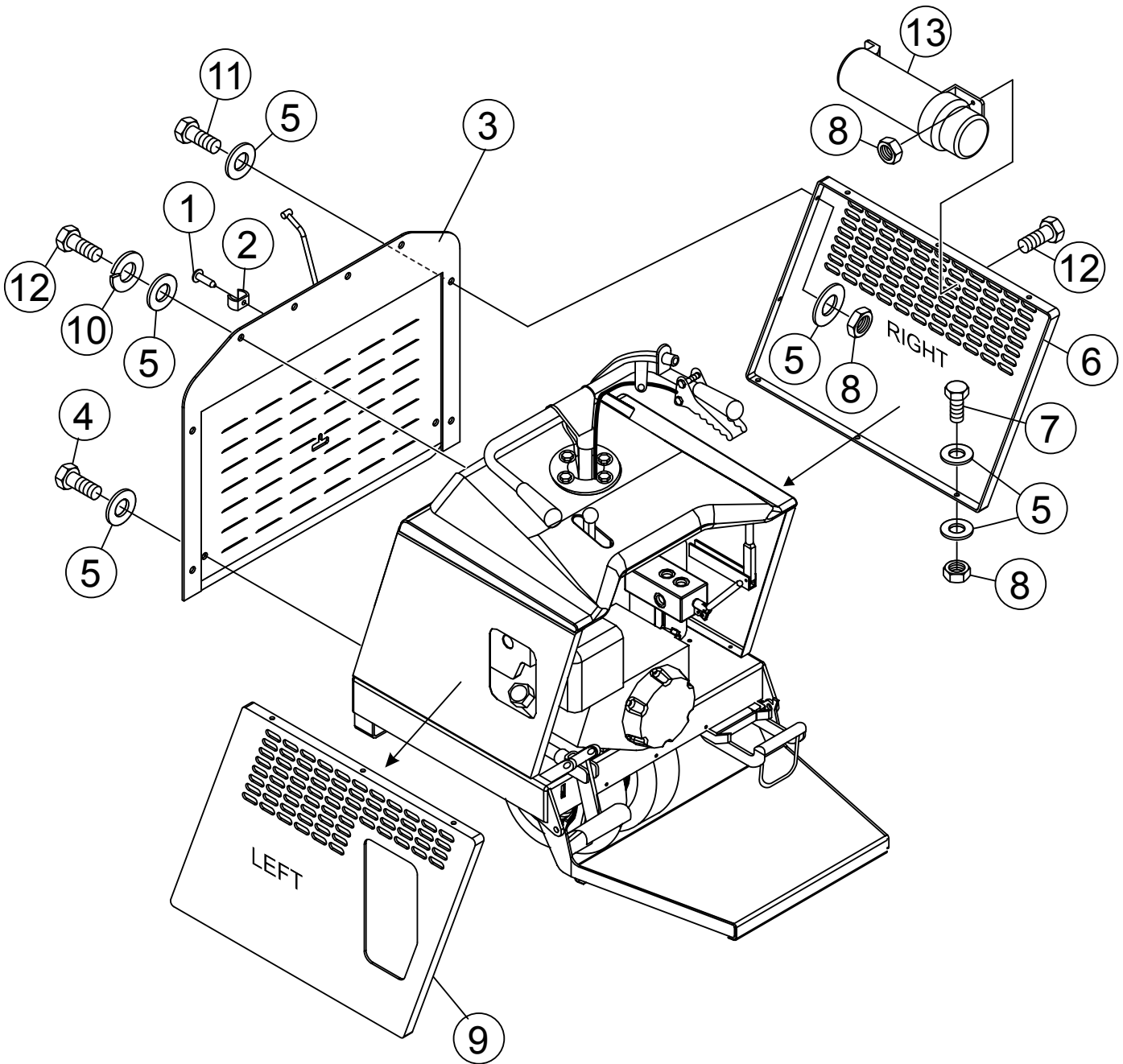

PANEL ASSY.

<u>NO.</u>	<u>PART NO.</u>	<u>PART NAME</u>	<u>QTY.</u>	<u>REMARKS</u>
1	503978	POP RIVET AM-56	1	
2	511474	FASTENER, ACCESS DOOR	1	
3	18008	DOOR, ACCESS	1	
4	492355	SCREW, 1/4 NC X 1/2 IN. G5	2	
5	492597	WASHER, FLAT 9.5X22.2	26	
6	18141	COVER, R/SIDE ENGINE	1	
7	492364	SCREW, HHC 5/16-18X1	6	
8	492582	NUT, NYLOC 5/16-18	6	
9	801026	COVER, L/SIDE ENGINE	1	
10	492623	WASHER, LOCK 5/16	4	
11	505401	SCREW, HHC 5/16-18X 1/2	4	
12	492363	SCREW, HHC 5/16 NC X 3/4 G5	6	
13	23297	MANUAL HOLDER	1	

BRAKE ASSY.

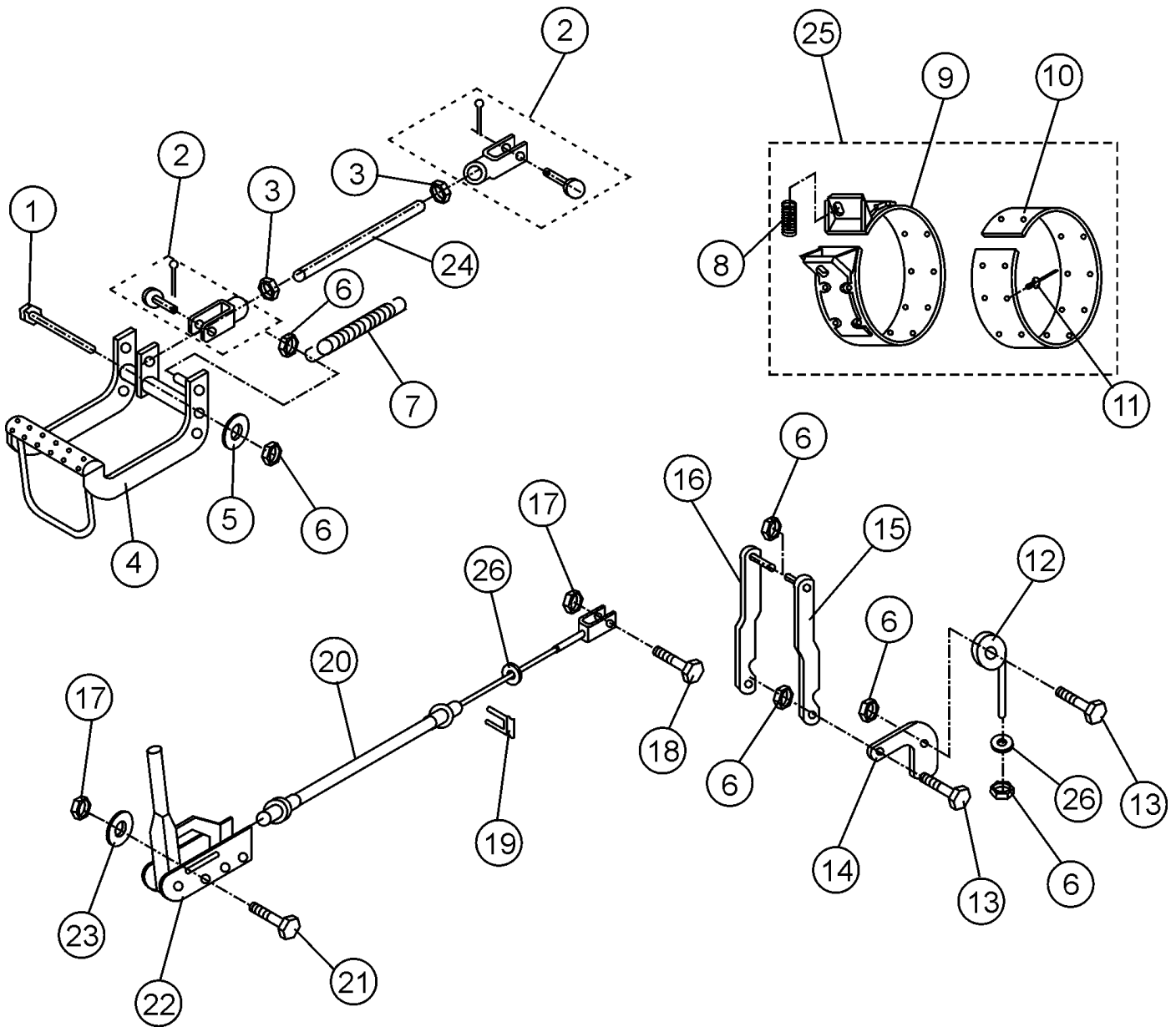

BRAKE ASSY.

<u>NO.</u>	<u>PART NO.</u>	<u>PART NAME</u>	<u>QTY.</u>	<u>REMARKS</u>
1	511762	SCREW, HHC 1/2-13X8	1	
2	511698	CLEVIS, ASSY. BRAKE	2	
3	511761	NUT, HEX 3/8-24 NF	2	
4	18111	PEDAL, BRAKE	1	
5	492600	WASHER, FLAT 1/2	1	
6	492584	NUT, NYLOC 1/2-13	10	
7	18167	SPRING, BRAKE PEDAL	1	
8*	18307	SPRING, BRAKE	2	
9*	18300	BAND, BRAKE	2	
10*	18316	LINING, BRAKE	2	
11*	503723	RIVET, BRAKE LINING	56	
12	18303	SHAFT, CRANK PIN	2	
13	492395	SCREW, HHC 1/2-13X1-3/4	2	
14	18302	BELL CRANK, BRAKE	2	
15	18032	LINKAGE, RIGHT BRAKE	1	
16	18314	LINKAGE, LEFT BRAKE	1	
17	492582	NUT, NYLOC 5/16-18	2	
18	492303	SCREW, HHC 5/16-18X1-14	1	
19	505170	CLIP, PARK CABLE	1	
20	18016	CABLE, PARK BRAKE	1	
21	492367	SCREW, HHC 5/16-18X1-3/4	3	
22	18015	LEVER, ASSY. PARK BRAKE	1	
23	492597	WASHER, FLAT 9.5X22.2	3	
24	18145	ROD, BRAKE CONTROL	1	
25	512881	BRAKE BAND ASSEMBLY	2.....	INCLUDES ITEMS W/ *
26	492600	WASHER, FLAT 1/2 IN.	2	

STEERING ASSY.

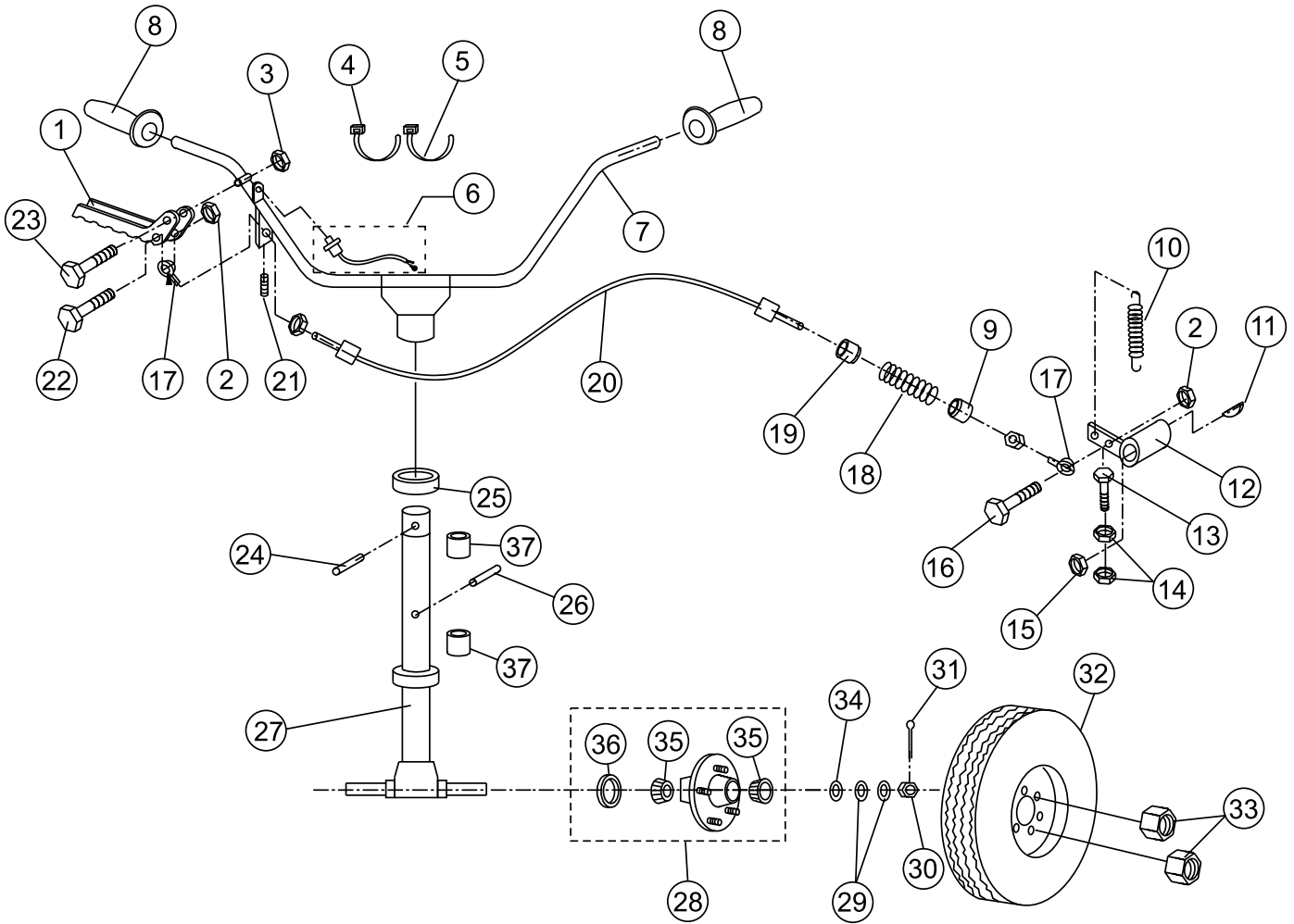

STEERING ASSY.

<u>NO.</u>	<u>PART NO.</u>	<u>PART NAME</u>	<u>QTY.</u>	<u>REMARKS</u>
1	18132	LEVER, THROTTLE	1	
2	492581	NUT, NYLOC 1/4-20	1	
3	492582	NUT, NYLOC 5/16-18	1	
4	491030	WRAP, T1Z	1	
5	504505	WRAP, T1E	1	
6	18025	SWITCH, KILL	1	
7	18242	HANDLE BAR	1	
8	511432	GRIP, HANDLE	2	
9	18181	BUSHING, CABLE	1	
10	18177	SPRING	1	
11	511717	KEY, WOODRUFF 1/8X5/8	1	
12	18061	LEVER, CONTROL	1	
13	512414	SCREW, HHC 1/4-20 X 2-1/4	1	
14	492561	NUT, HEX 1/4-20	2	
15	492584	NUT, NYLOC 1/2-13	1	
16	492357	SCREW, HHC 1/4-20X1	1	
17	18183	CONNECTOR, THROTTLE CABLE END	2	
18	18176	SPRING	1	
19	18182	BUSHING, CABLE	1	
20	18133	CABLE, THROTTLE	1	
21	492465	SCREW, ALLEN HEAD 1/4-20 X3/8	1	
22	506088	SCREW, HHC 1/4-20X3/8	1	
23	492369	SCREW, HHC 5/16-18X2-1/4	1	
24	491723	PIN, STEERING SHAFT	1	
25	18238	BUSHING, STEERING SHAFT	2	
26	512186	PIN, STEERING SHAFT	1	
27	18091	AXLE, STEERING	1	
28	EM941306	HUB, REAR WHEEL.....	2.....	INCLUDES ITEMS W/ #
29	EM501299	WASHER, REAR WHEEL HUB	2	
30	512210	NUT, CASTLE	2	
31	491688	PIN, COTTER 1/8 X 1-1/2	2	
32	18049	WHEEL, STEERING ASSY. REAR	2	
33	8115	NUT LUG	8	
34	511159	WASHER, FLAT 1 IN.	2	
35#	EM903113	BEARING CONE	2	
36#	15191VB	SEAL	1	
37	512200	BUSHING, BRONZE	2	

CHASSIS ASSY.

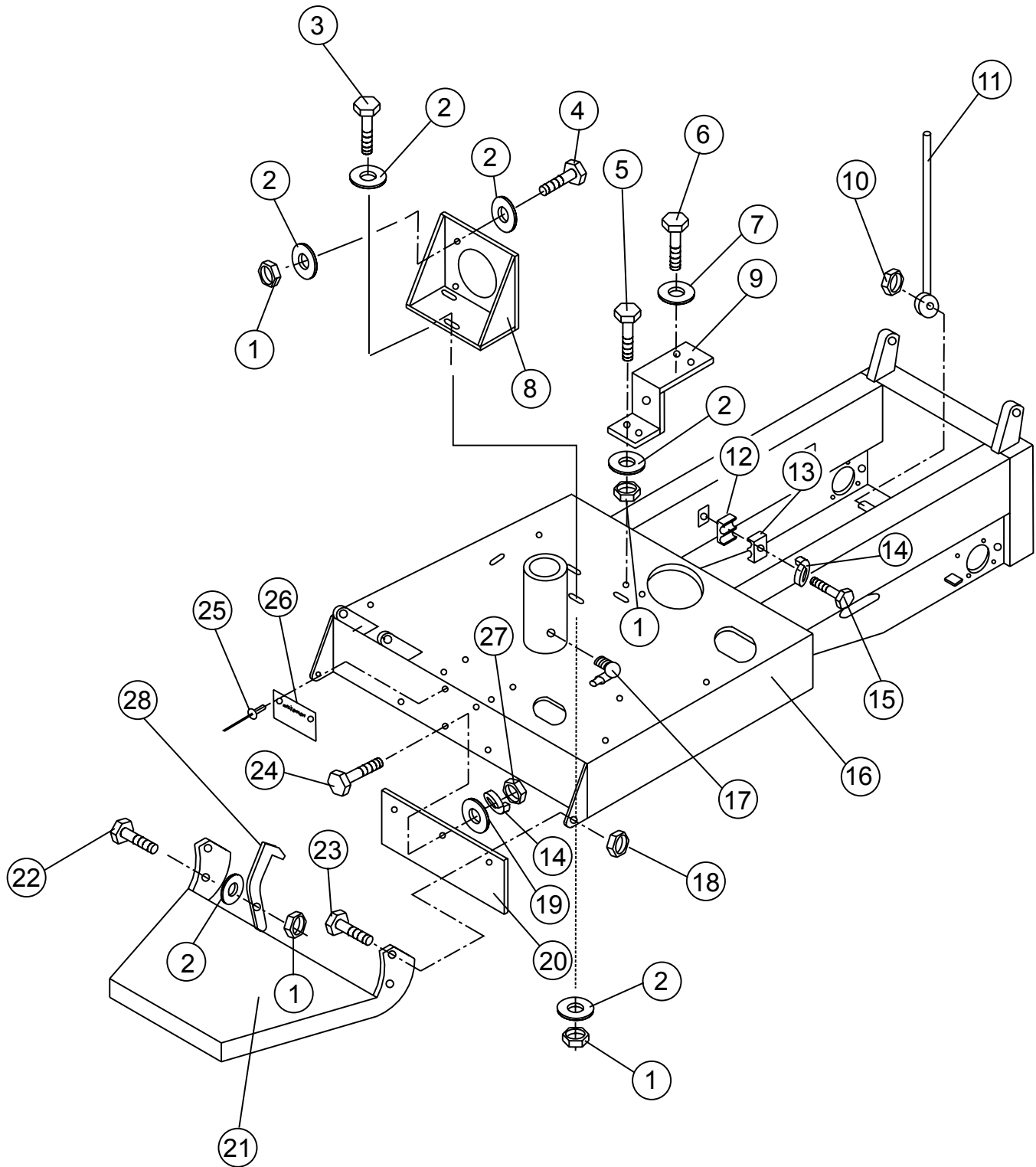

CHASSIS ASSY.

<u>NO.</u>	<u>PART NO.</u>	<u>PART NAME</u>	<u>QTY.</u>	<u>REMARKS</u>
1	492583	NUT, NYLOC 3/8	10	
2	492598	WASHER, FLAT 3/8	18	
3	492313	SCREW, HHC 3/8 - 16 X 1-1/2	3	
4	503112	SCREW, HHC 3/8 - 16 X 2-3/4	4	
5	492375	SCREW, HHC 3/8 - 16 X 12	2	
6	492357	SCREW, HHC 1/4 - 20 X 12	2	
7	492622	WASHER, LOCK 1/4	2	
8	512196	BRACKET, HYD. PUMP MOUNTING	1	
9	18146	MOUNT, OIL FILTER	1	
10	505069	NUT, NYLOC 3/4-10	1	
11	18198	ROD, TUB PROP	1	
12	505976	CLAMP, BRACKET	2	
13	506185	CLAMP, BRACKET	2	
14	492623	WASHER, LOCK 5/16	5	
15	492366	SCREW, HHC 5/16- 18 X 1-1/2	2	
16	18047	CHASSIS	1	
17	503901	ZERK FITTING 1/4- 28	1	
18	492586	NUT, NYLOC 5/8-11	2	
19	492597	WASHER, FLAT 9.5 X 22.2	3	
20	18162	PANEL, REAR WHEEL COVER	1	
21	18222	PLATFORM, OPERATOR	1	
22	492313	SCREW, HHC 3/8 - 16 X 1-1/2	1	
23	492406	SCREW, HHC 5/8 - 11 X 1-1/2	2	
24	492363	SCREW, HHC 5/16 - 18 X 3/4	3	
25	491757	RIVET, I.D. PLATE	2	
26		PLATE, SERIAL NUMBER.....	1CONTACT MQ PARTS DEPT.
27	492553	NUT, HEX 5/16- 18	3	
28	18173	LATCH, PLATFORM	1	

DUMP PEDAL AND HANDLE ASSY.

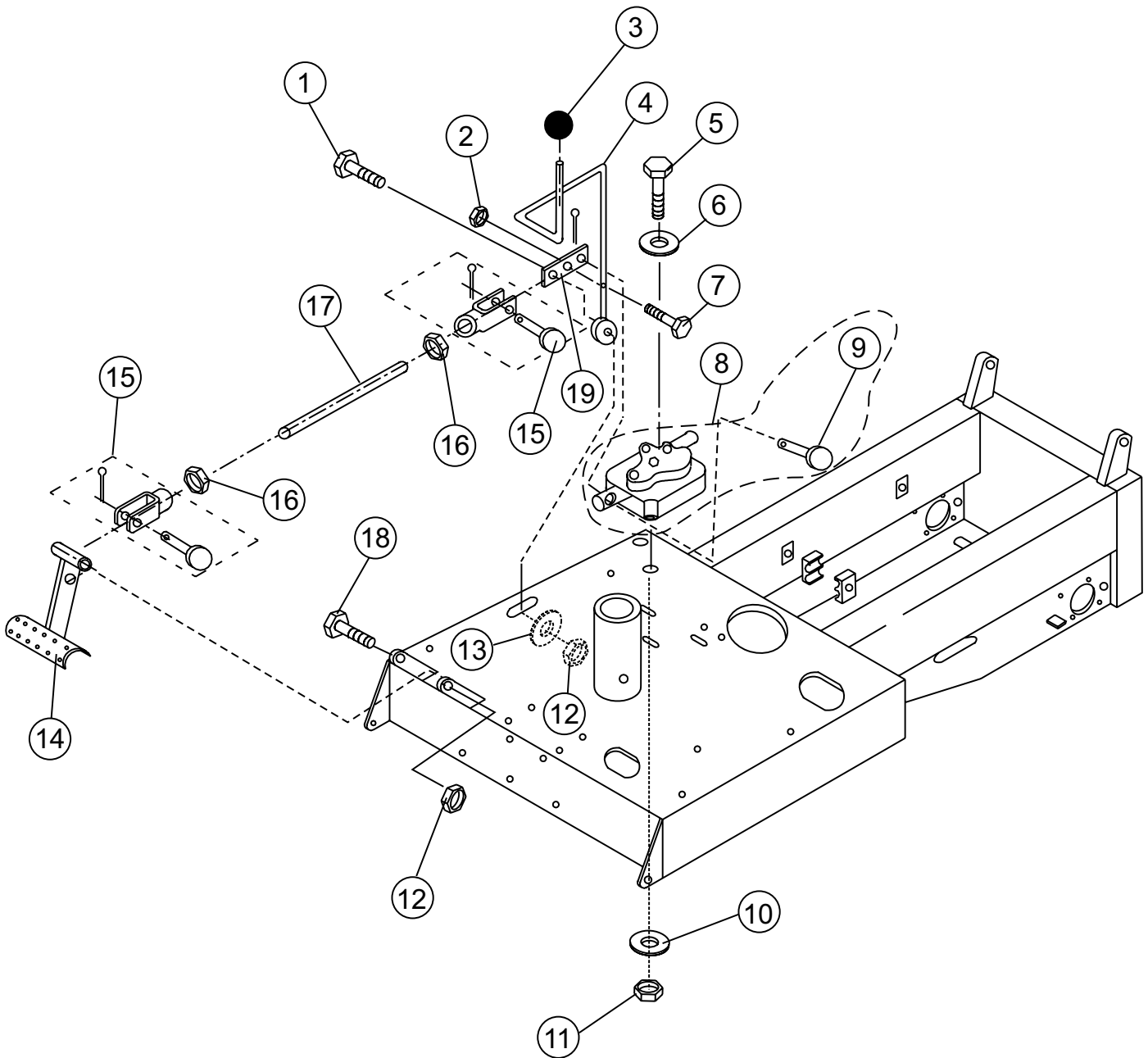

DUMP PEDAL AND HANDLE ASSY.

<u>NO.</u>	<u>PART NO.</u>	<u>PART NAME</u>	<u>QTY.</u>	<u>REMARKS</u>
1	492401	SCREW, HHC 1/2- 13 X 4	1	
2	512184	NUT, NYLOC 3/16- 24	1	
3	18121	KNOB, LEVER	1	
4	18065	LEVER, DUMP VALVE	1	
5	512185	SCREW, HHC 1/4- 20 X1- 3/4	2	
6	492622	WASHER, LOCK 1/4	1	
7	512183	SCREW, HHC 3/16- 24 X1- 1/4	1	
8	18064	VALVE, DUMP	1	INCLUDES ITEMS W/ *
9*		PIN, DUMP VALVE CROSS.....	1	NOT SOLD SEPARATELY
10	492596	WASHER, FLAT 1/4	1	
11	492581	NUT, NYLOC 1/4- 20	1	
12	492584	NUT, NYLOC 1/2- 13	2	
13	492600	WASHER, FLAT 1/2	1	
14	18152	PEDAL, DUMP VALVE	1	
15	18123	CLEVIS , ASSY. DUMP VALVE	2	
16	511761	NUT, HEX 3/8- 24 NF	2	
17	18153	ROD, DUMP VALVE	1	
18	492400	SCREW, HHC 1/2- 13 X 3- 1/2	1	
19	18122	BELL CRANK, DUMP VALVE	1	

HYDRAULIC OIL TANK ASSY.

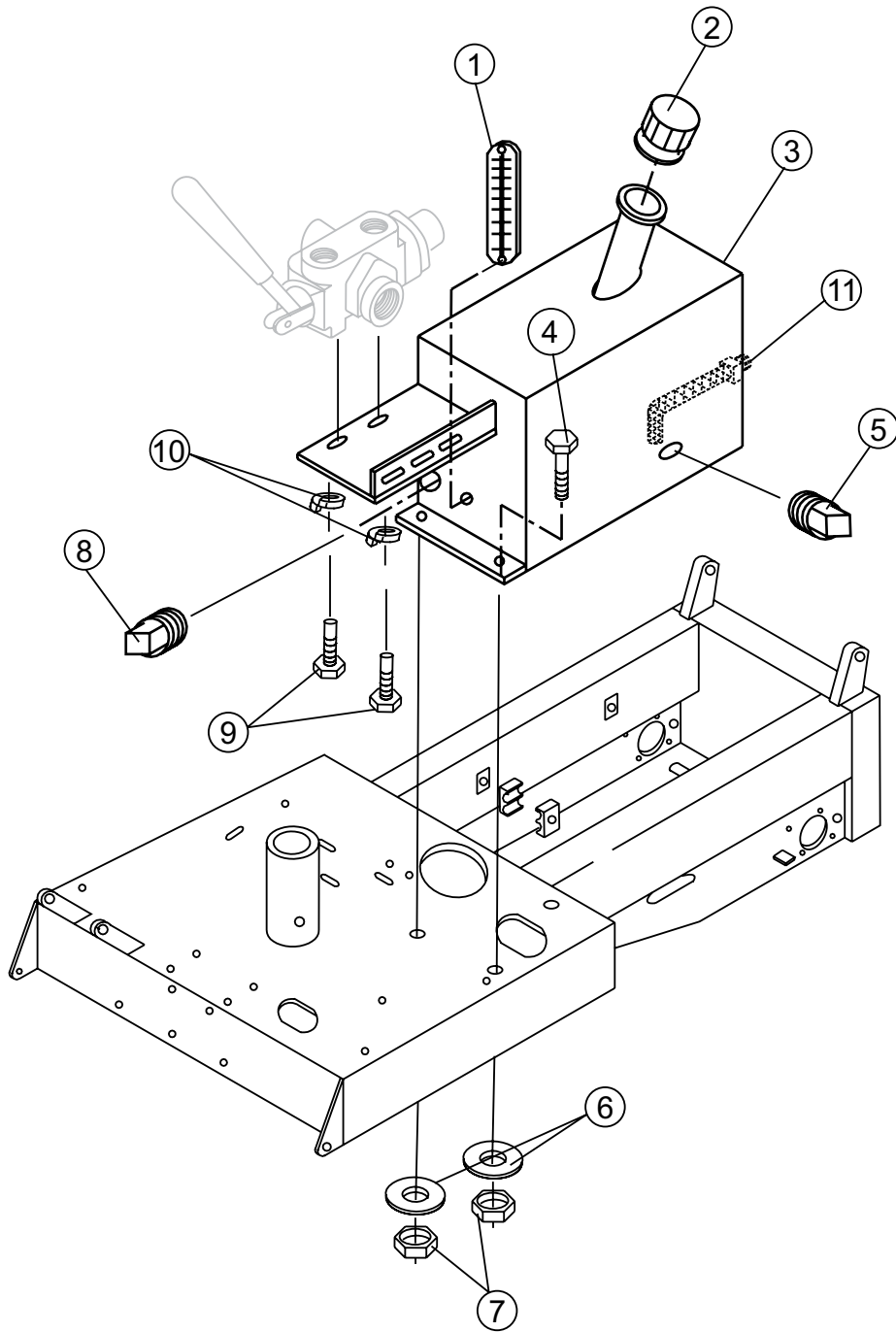

HYDRAULIC OIL TANK ASSY.

<u>NO.</u>	<u>PART NO.</u>	<u>PART NAME</u>	<u>QTY.</u>	<u>REMARKS</u>
1	3336	SIGHT GAUGE, HYD. OIL TANK	1	
2	16477	CAP, HYD. OIL TANK	1	
3	18113	TANK HYD. OIL	1	
4	492375	SCREW, HHC 3/8- 16 X1	3	
5	491212	PLUG, HYD. OIL TANK 1/2"	1	
6	492598	WASHER, FLAT 3/8	3	
7	492583	NUT, NYLOC 3/8- 16	3	
8	49123	PLUG, HYD. OIL TANK 3/4	1	
9	492373	SCREW, HHC 3/8- 16 X 3/4	2	
10	492624	WASHER, LOCK 3/8	2	
11	18229	SCREEN, OIL RESERVOIR	2	

BATTERY ASSY. (ELECTRIC START)

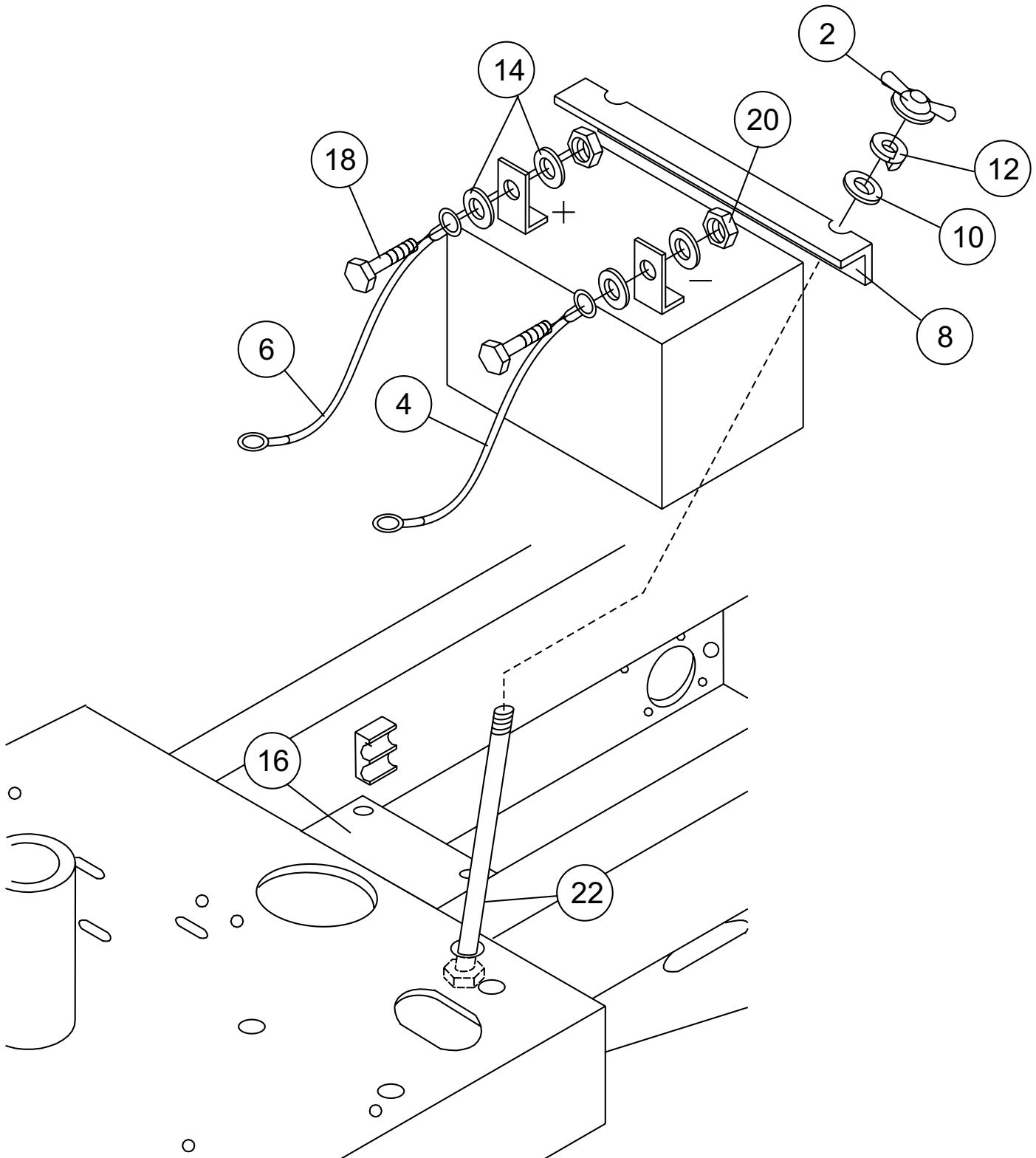

BATTERY ASSY. (ELECTRIC START)

<u>NO.</u>	<u>PART NO.</u>	<u>PART NAME</u>	<u>QTY.</u>	<u>REMARKS</u>
2	505500	WINGNUT	2	
4	512557	BATTERY CABLE, NEGATIVE	1	
6	511250	BATTERY CABLE, POSITIVE	1	
8	512555	BATTERY SUPPORT BRACKET	1	
10	492596	WASHER, FLAT 1/4"	2	
12	492622	WASHER, LOCK 1/4"	2	
14	492595	WASHER, FLAT 3/16"	4	
16	508480	BATTERY SUPPORT PLATFORM	1	
18	503118	BOLT 3/16" x 1"	2	
20	503119	NUT 3/16"	2	
22	512585	SUPPORT BRACKET BOLT	2	
24	4671	BATTERY	1	

FUEL ASSY.

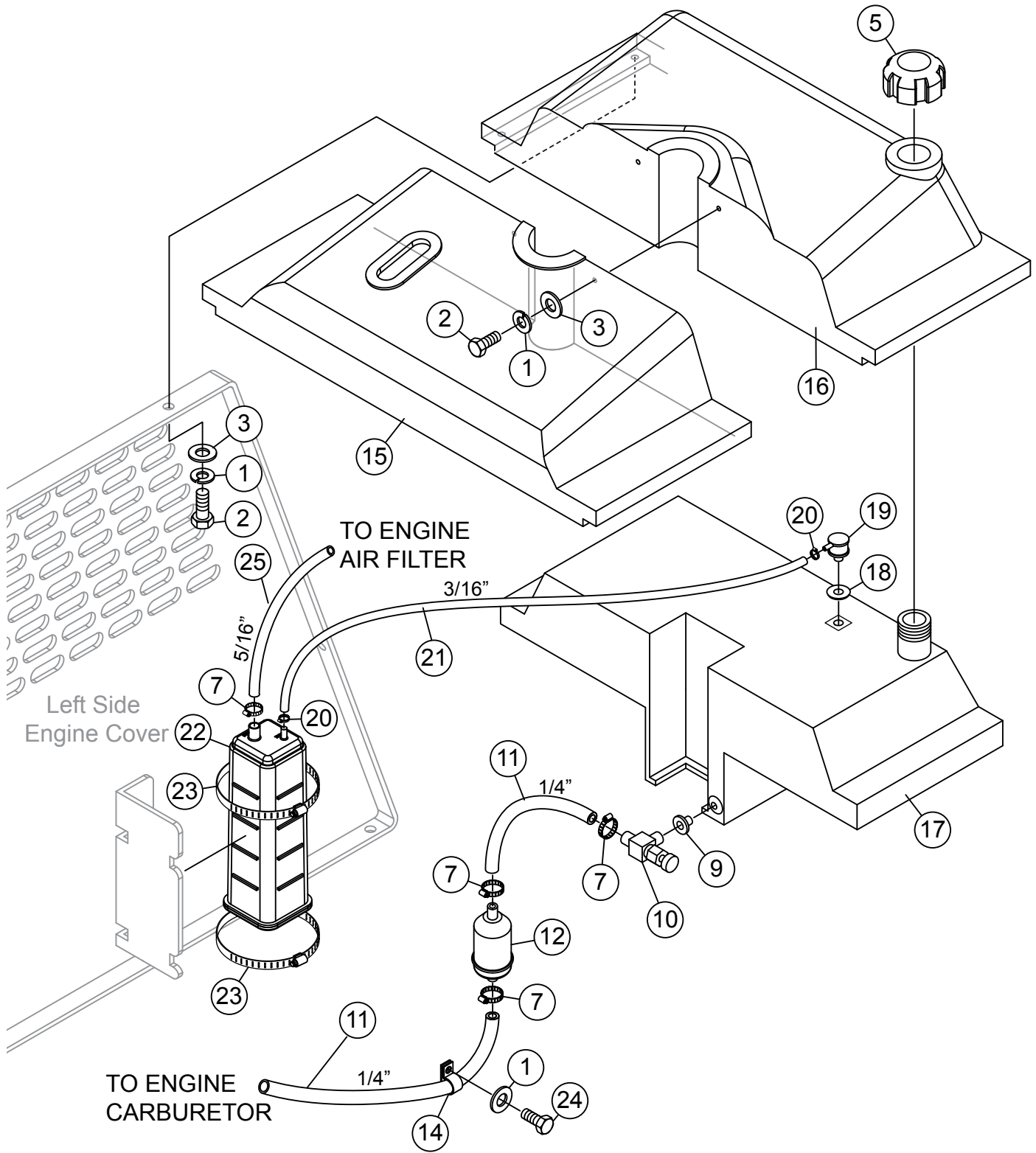

FUEL ASSY.

<u>NO.</u>	<u>PART NO.</u>	<u>PART NAME</u>	<u>QTY.</u>	<u>REMARKS</u>
1	492622	WASHER, LOCK 1/4 IN.	5	
2	492356	SCREW, 1/4 x 3/4 IN. G5	4	
3	509161	WASHER, FLAT 1/4 IN.	4	
5	520820	CAP, FUEL (EPA)	1	
7	506208	CLAMP, FUEL HOSE	4	
9	19633	SEAL, FUEL TANK GROMMET	1	
10	20795	VALVE, FUEL SHUT-OFF	1	
11	60013	HOSE, FUEL EPA 1/4"	AR	
12	20763	FILTER, FUEL	2	
14	511807	STRAP NYLON 5/8	1	
15	515386	COVER, FUEL TANK	1	
16	800845	SECTION COVER, FUEL TANK	1	
17	800841	TANK, FUEL	1	
18	23507	GROMMET, FUEL VALVE	1	
19	23508	VALVE, FUEL	1	
20	517621	CLAMP	2	
21	60004	HOSE, FUEL EPA 3/16"	AR	
22	23505	CANNISTER, CHARCOAL 390CC	1	
23	510725	CLAMP	2	
24	492355	SCREW, 1/4 NC X 1/2 IN. G5	1	
25	60028	HOSE, FUEL EPA 5/16"	AR	

AR — AS REQUIRED

20763

ENGINE ASSY.

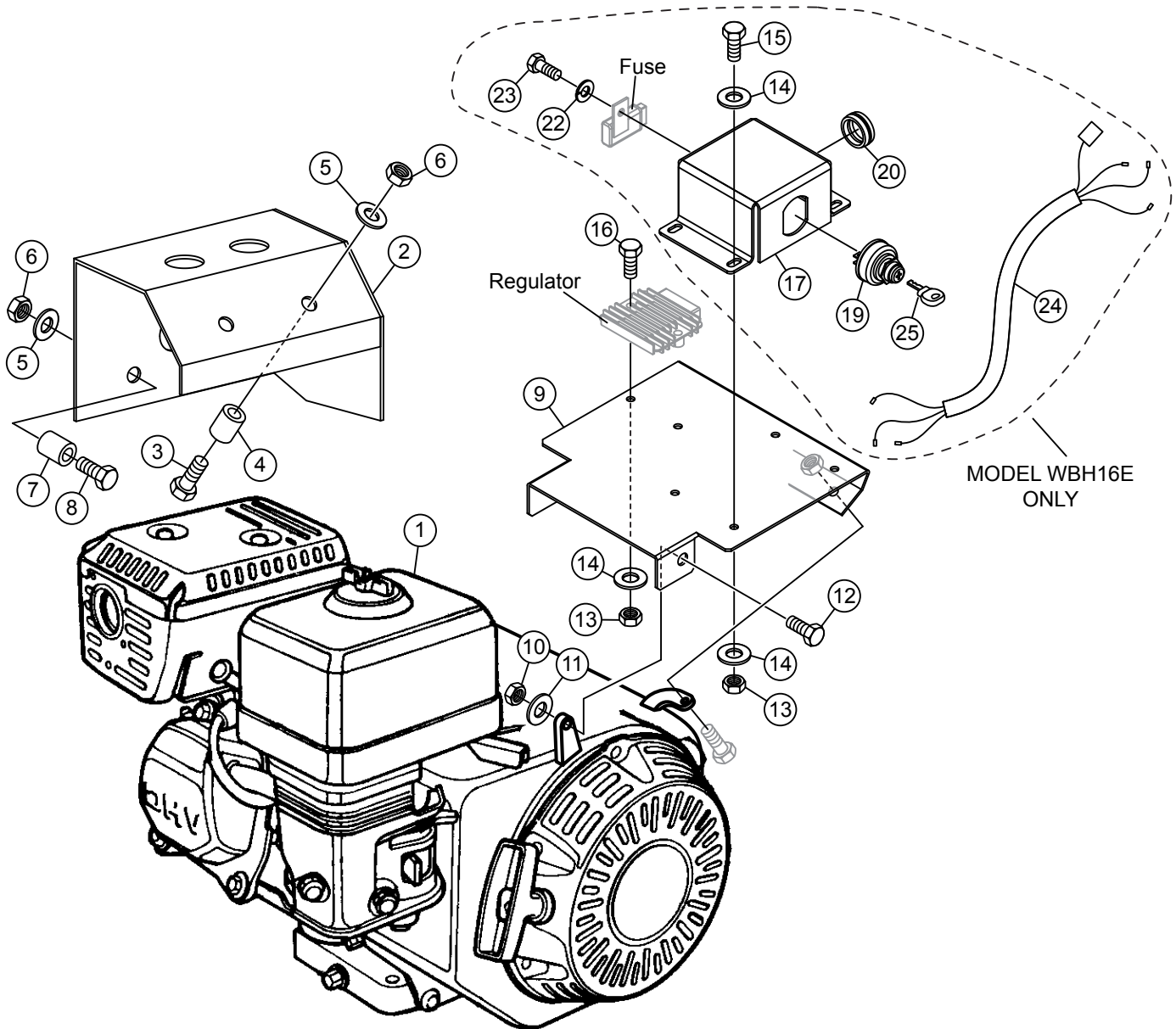

MODEL WBH16E
ONLY

ENGINE ASSY.

<u>NO.</u>	<u>PART NO.</u>	<u>PART NAME</u>	<u>QTY.</u>	<u>REMARKS</u>
1	GX390RT2QTT	ENGINE, HONDA 11 HP RECOIL START	1	
1	GX390RT2QNB2	ENGINE, HONDA 11 HP ELECTRIC START	1	
2	801029	GUARD, MUFFLER	1	
3	503118	BOLT, 3/16" NC X 1" G2	2	
4	512512	SPACER	2	
5	492595	WASHER, FLAT 3/16"	4	
6	503119	NUT, 3/16" NC	4	
7	512507	SPACER	2	
8	508998	BOLT, 3/16" NC X 1-1/2"	2	
9	18007	MOTOR COVER	1	
10	492583	NUT, 3/8" NC	2	
11	492598	WASHER 3/8"	2	
12	492313	BOLT, 3/8" NC X 1-1/2" G5	2	
13	492581	NUT, 1/4" NC	6	
14	492596	WASHER, FLAT 1/4"	10	
15	492356	BOLT, 2/4" NC X 3/4" G5	4	
16	492358	BOLT, 1/4" NC X 1-1/4" G5	2	
17	801019	IGNITION SWITCH BOX	1	
19	10958	IGNITION SWITCH	1	
20	800921	GROMMET	1	
22	492621	WASHER, LOCK 3/16"	1	
23	503115	BOLT, 3/16" NC X 3/4" G2	1	
24	801014	ELECTRICAL HARNESS	1	
25	11078	KEY, IGNITION SWITCH	1	

TERMS AND CONDITIONS OF SALE — PARTS

PAYMENT TERMS

Terms of payment for parts are net 30 days.

FREIGHT POLICY

All parts orders will be shipped collect or prepaid with the charges added to the invoice. All shipments are F.O.B. point of origin. Multiquip's responsibility ceases when a signed manifest has been obtained from the carrier, and any claim for shortage or damage must be settled between the consignee and the carrier.

MINIMUM ORDER

The minimum charge for orders from Multiquip is \$15.00 net. Customers will be asked for instructions regarding handling of orders not meeting this requirement.

RETURNED GOODS POLICY

Return shipments will be accepted and credit will be allowed, subject to the following provisions:

1. A Returned Material Authorization must be approved by Multiquip prior to shipment.
2. To obtain a Return Material Authorization, a list must be provided to Multiquip Parts Sales that defines item numbers, quantities, and descriptions of the items to be returned.
 - a. The parts numbers and descriptions must match the current parts price list.
 - b. The list must be typed or computer generated.
 - c. The list must state the reason(s) for the return.
 - d. The list must reference the sales order(s) or invoice(s) under which the items were originally purchased.
 - e. The list must include the name and phone number of the person requesting the RMA.
3. A copy of the Return Material Authorization must accompany the return shipment.
4. Freight is at the sender's expense. All parts must be returned freight prepaid to Multiquip's designated receiving point.

5. Parts must be in new and resalable condition, in the original Multiquip package (if any), and with Multiquip part numbers clearly marked.
6. The following items are not returnable:
 - a. Obsolete parts. (If an item is in the price book and shows as being replaced by another item, it is obsolete.)
 - b. Any parts with a limited shelf life (such as gaskets, seals, "O" rings, and other rubber parts) that were purchased more than six months prior to the return date.
 - c. Any line item with an extended dealer net price of less than \$5.00.
 - d. Special order items.
 - e. Electrical components.
 - f. Paint, chemicals, and lubricants.
 - g. Decals and paper products.
 - h. Items purchased in kits.
7. The sender will be notified of any material received that is not acceptable.
8. Such material will be held for five working days from notification, pending instructions. If a reply is not received within five days, the material will be returned to the sender at his expense.
9. Credit on returned parts will be issued at dealer net price at time of the original purchase, less a 15% restocking charge.
10. In cases where an item is accepted, for which the original purchase document can not be determined, the price will be based on the list price that was effective twelve months prior to the RMA date.
11. Credit issued will be applied to future purchases only.

PRICING AND REBATES

Prices are subject to change without prior notice. Price changes are effective on a specific date and all orders received on or after that date will be billed at the revised price. Rebates for price declines and added charges for price increases will not be made for stock on hand at the time of any price change.

Multiquip reserves the right to quote and sell direct to Government agencies, and to Original Equipment Manufacturer accounts who use our products as integral parts of their own products.

SPECIAL EXPEDITING SERVICE

A \$35.00 surcharge will be added to the invoice for special handling including bus shipments, insured parcel post or in cases where Multiquip must personally deliver the parts to the carrier.

LIMITATIONS OF SELLER'S LIABILITY

Multiquip shall not be liable hereunder for damages in excess of the purchase price of the item with respect to which damages are claimed, and in no event shall Multiquip be liable for loss of profit or good will or for any other special, consequential or incidental damages.

LIMITATION OF WARRANTIES

No warranties, express or implied, are made in connection with the sale of parts or trade accessories nor as to any engine not manufactured by Multiquip. Such warranties made in connection with the sale of new, complete units are made exclusively by a statement of warranty packaged with such units, and Multiquip neither assumes nor authorizes any person to assume for it any other obligation or liability whatever in connection with the sale of its products. Apart from such written statement of warranty, there are no warranties, express, implied or statutory, which extend beyond the description of the products on the face hereof.

Effective: February 22, 2006

OPERATION AND PARTS MANUAL

HERE'S HOW TO GET HELP

PLEASE HAVE THE MODEL AND SERIAL
NUMBER ON-HAND WHEN CALLING

UNITED STATES

Multiquip Corporate Office

18910 Wilmington Ave.
Carson, CA 90746
Contact: mq@multiquip.com

Tel. (800) 421-1244
Fax (800) 537-3927

MQ Parts Department

800-427-1244
310-537-3700

Fax: 800-672-7877
Fax: 310-637-3284

Service Department

800-421-1244
310-537-3700

Fax: 310-537-4259

Warranty Department

800-421-1244
310-537-3700

Fax: 310-943-2249

Technical Assistance

800-478-1244

Fax: 310-943-2238

MEXICO

MQ Cipsa

Carr. Fed. Mexico-Puebla KM 126.5
Momoxpan, Cholula, Puebla 72760 Mexico
Contact: pmastretta@cipsa.com.mx

Tel: (52) 222-225-9900
Fax: (52) 222-285-0420

UNITED KINGDOM

Multiquip (UK) Limited Head Office

Unit 2, Northpoint Industrial Estate,
Globe Lane,
Dukinfield, Cheshire SK16 4UJ
Contact: sales@multiquip.co.uk

Tel: 0161 339 2223
Fax: 0161 339 3226

CANADA

Multiquip

4110 Industriel Boul.
Laval, Quebec, Canada H7L 6V3
Contact: jmartin@multiquip.com

Tel: (450) 625-2244
Tel: (877) 963-4411
Fax: (450) 625-8664

© COPYRIGHT 2011, MULTIQUIP INC.

Multiquip Inc, the MQ logo and the Whiteman logo are registered trademarks of Multiquip Inc. and may not be used, reproduced, or altered without written permission. All other trademarks are the property of their respective owners and used with permission.

This manual MUST accompany the equipment at all times. This manual is considered a permanent part of the equipment and should remain with the unit if resold.

The information and specifications included in this publication were in effect at the time of approval for printing. Illustrations, descriptions, references and technical data contained in this manual are for guidance only and may not be considered as binding. Multiquip Inc. reserves the right to discontinue or change specifications, design or the information published in this publication at any time without notice and without incurring any obligations.

Your Local Dealer is:

