

PARTS AND OPERATION MANUAL

Multiquip DS-Series DuoScreed

© COPYRIGHT 2001, MULTQUIP INC.

Revision #1 (03/06/01)



MULTQUIP INC.

18910 WILMINGTON AVE.
CARSON, CALIFORNIA 90746
310-537-3700

800-421-1244
FAX: 310-537-3927

PARTS DEPARTMENT:

800-427-1244
FAX: 800-672-7877

SERVICE DEPARTMENT:

800-478-1244
FAX: 310-537-4259

E-mail: mq@multiquip.com • **www:** www.multiquip.com

Atlanta • Boise • Dallas • Houston • Newark
Montreal, Canada • Manchester, UK
Rio De Janeiro, Brazil • Guadalajara, Mexico



WARNING



CALIFORNIA — Proposition 65 Warning

Engine exhaust and some of its constituents, and some dust created by power sanding, sawing, grinding, drilling and other construction activities contains chemicals known to the State of California to cause cancer, birth defects and other reproductive harm. Some examples of these chemicals are:

- Lead from lead-based paints.
- Crystalline silica from bricks.
- Cement and other masonry products.
- Arsenic and chromium from chemically treated lumber.

Your risk from these exposures varies, depending on how often you do this type of work. To reduce your exposure to these chemicals: **ALWAYS** work in a well ventilated area, and work with approved safety equipment, such as dust masks that are specially designed to filter out microscopic particles.

HERE'S HOW TO GET HELP

*PLEASE HAVE THE MODEL AND SERIAL NUMBER
ON-HAND WHEN CALLING*

PARTS DEPARTMENT

800-427-1244 or 310-537-3700

FAX: 800-672-7877 or 310-637-3284

SERVICE DEPARTMENT/TECHNICAL ASSISTANCE

800-478-1244 or 310-537-3700

FAX: 310- 537-4259

WARRANTY DEPARTMENT

888-661-4279, or 310-661-4279

FAX: 310- 537-1173

MAIN

800-421-1244 or 310-537-3700

FAX: 310-537-3927

Here's How To Get Help 3
 Table Of Contents 4
 Parts Ordering Procedures 5
 Rules For Safe Operation 6-7
 Operation and Safety Decals 8
 Specifications 9
 General Information 10

Multiquip DS-Series — Vibratory DuoScreed

Components (DuoScreed) 11
 Components (Honda GX31SA Engine) 12
 Assembly Instructions 13-15
 Starting 16
 Application/Operation 17-20
 Maintenance 21-22
 Troubleshooting (DuoScreed) 23
 Troubleshooting (Honda GX31SA Engine) 24
 Explanation Of Codes In Remarks Column 26
 Suggested Spare Parts 27
 Main Assembly 28-31
 Name Plate And Decals 32-33

Honda GX31SA Engine

Crankcase Assembly 34-35
 Camshaft Assembly 36-37
 Piston Crankshaft Assembly 38-39
 Carburetor Assembly 40-41
 Recoil Starter Assembly 42-43
 Flywheel/Ignition Coil Assembly 44-45
 Fuel Tank 46-47
 Air Cleaner Assembly 48-49
 Muffler Assembly 50-51
 Clutch/Fan Cover Assembly 52-53
 Engine Cover Assembly 54-55

Terms and Conditions Of Sale — Parts 56

NOTE

*Specification and part number
are subject to change without
notice.*

- Dealer account number
- Dealer name and address
- Shipping address (if different than billing address)
- Return fax number
- Applicable model number
- Quantity, part number and description of each part
- Specify preferred method of shipment:
 - UPS Ground
 - UPS Second Day or Third Day*
 - UPS Next Day*
 - Federal Express Priority One (please provide us with your Federal Express account number)*
 - Airborne Express*
 - Truck or parcel post

**Normally shipped the same day the order is received, if prior to 2PM west coast time.*

Earn Extra Discounts when you order by FAX!

All parts orders which include complete part numbers and are received by fax qualify for the following extra discounts:

<u>Number of line items ordered</u>	<u>Additional Discount</u>
1-9 items	3%
10+ items**	5%

Get special freight allowances when you order 10 or more line items via FAX! **

- UPS Ground Service at no charge for freight
- PS Third Day Service at one-half of actual freight cost

No other allowances on freight shipped by any other carrier.

**Common nuts, bolts and washers (all items under \$1.00 list price) do not count towards the 10+ line items.

DISCOUNTS ARE SUBJECT TO CHANGE

Fax order discount and UPS special programs revised June 1, 1995

**Extra Fax Discount
for Domestic USA
Dealers Only**

**Up to 5%
extra savings!**

**UPS
Special**
For faxed orders only

**Now! Direct TOLL-FREE access
to our Parts Department!**

Toll-free nationwide:

800-421-1244

Toll-free FAX:

800/6-PARTS-7 • 800-672-7877

DS-SERIES DUOSCREED — RULES FOR SAFE OPERATION

CAUTION:



Failure to follow instructions in this manual may lead to serious injury or even death! This equipment is to be operated by trained and qualified personnel only! This equipment is for industrial use only.

The following safety guidelines should always be used when operating the DuoScreed

GENERAL SAFETY

- **DO NOT** operate or service this equipment before reading this entire manual.



- This equipment should not be operated by persons under 18 years of age.

- **NEVER** operate this equipment without proper protective clothing, shatterproof glasses, steel-toed boots and other protective devices required by the job.



- **NEVER** operate this equipment when not feeling well due to fatigue, illness or taking medicine.



- **NEVER** operate this equipment under the influence of drugs or alcohol.



- **NEVER** use accessories or attachments, which are not recommended by Multiquip for this equipment. Damage to the equipment and/or injury to user may result.

- Manufacturer does not assume responsibility for any accident due to equipment modifications.

- Whenever necessary, replace nameplate, operation and safety decals when they become difficult to read.

- Always check the machine for loosened threads or bolts before starting.

- **NEVER** touch the hot exhaust manifold, muffler or cylinder. Allow these parts to cool before servicing engine or DuoScreed.

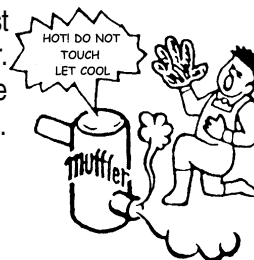

- **High Temperatures** – Allow the engine to cool before adding fuel or performing service and maintenance functions. Contact with *hot* components can cause serious burns.

- The DuoScreed engine requires an adequate free flow of cooling air. Never operate the DuoScreed in any enclosed or narrow area where free flow of the air is restricted. If the air flow is restricted it will cause serious damage to the DuoScreed or engine and may cause injury to people. Remember the DuoScreed's engine gives off **DEADLY** carbon monoxide gas.

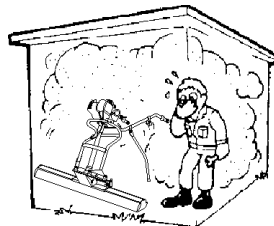

- Always refuel in a well-ventilated area, away from sparks and open flames.



- Always use extreme caution when working with **flammable** liquids. When refueling, **stop the engine** and allow it to cool. **DO NOT smoke** around or near the machine. Fire or explosion could result from fuel vapors, or if fuel is spilled on a hot engine.

- **NEVER** operate the DuoScreed in an explosive atmosphere or near combustible materials. An explosion or fire could result causing severe *bodily harm or even death*.

- Topping-off to filler port is dangerous, as it tends to spill fuel.

DS-SERIES DUOSCREED — RULES FOR SAFE OPERATION

- Always read, understand, and follow procedures in Operator's Manual before attempting to operate equipment.
- Always be sure the operator is familiar with proper safety precautions and operations techniques before using DuoScreed.
- Refer to the *HONDA Engine Owner's Manual* for engine technical questions or information.
- **NEVER** use accessories or attachments, which are not recommended by Multiquip for this equipment. Damage to the equipment and/or injury to user may result.
- **NEVER** Run engine without air cleaner. Severe engine damage may occur.
- Always service air cleaner frequently to prevent carburetor malfunction.
- Always store equipment properly when it is not being used. Equipment should be stored in a clean, dry location out of the reach of children.

Transporting

- Always shutdown engine before transporting.
- Tighten fuel tank cap securely and close fuel cock to prevent fuel from spilling.
- Drain fuel when transporting DuoScreed over long distances or bad roads.
- Always tie-down the DuoScreed during transportation by securing the DuoScreed with rope.

Emergencies

- Always know the location of the nearest *fire extinguisher* and *first aid kit*. Know the location of the nearest telephone. Also know the phone numbers of the nearest *ambulance*, *doctor* and *fire department*. This information will be invaluable in the case of an emergency.







Maintenance Safety

- **NEVER** lubricate components or attempt service on a running machine.
- Always allow the machine a proper amount of time to cool before servicing.
- Keep the machinery in proper running condition.
- Fix damage to the machine immediately and always replace broken parts.
- Dispose of hazardous waste properly. Examples of potentially hazardous waste are used motor oil, fuel and fuel filters.
- **DO NOT** use plastic containers to dispose of hazardous waste.
- **DO NOT** pour waste, oil or fuel directly onto the ground, down a drain or into any water source

DS-SERIES DUOSCREED — OPERATION AND SAFETY DECALS

Machine Safety Decals

The DUOSCREED is equipped with a number of safety decals. These decals are provided for operator safety and maintenance information. The illustrations below shows these decals as they appear on the machine. Should any of these decals become unreadable, replacements can be obtained from your dealer.

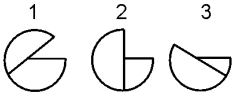
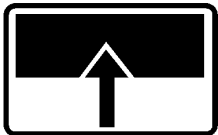
DuoScreed Safety Decals	
	Symbol indicates that it is mandatory to wear safety glasses, safety helmet and ear protection.
	Symbol indicates that it is mandatory to wear gloves.
	Symbol indicates that it is mandatory to wear safety shoes, with extra protection (steel toed).
	Symbol indicates unit <u>should not be</u> operated near flammable materials.
 P/N DCL121	Symbol indicates DO NOT use a pressure washer to clean unit.
	Symbol indicates unit complies with European standards.
<p>POSITIONS</p>  P/N DCL141	Symbol indicates position of eccentric weights depending on blade length.
 P/N DCL140	Symbol indicates alignment point when attaching blade to main body clamps.

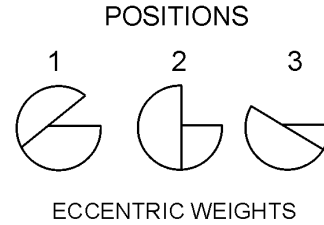

BLADE LENGTH		ECCENTRIC WEIGHT POSITION
FEET	METERS	
4.9	1.5	1
6.2	1.9	1
8.2	2.5	1
9.5	3.0	1
12.3	3.75	2
13.9	4.25	2
16.4	5.00	3
18.0	5.50	3
19.6	6.00	3

P/N DCL141

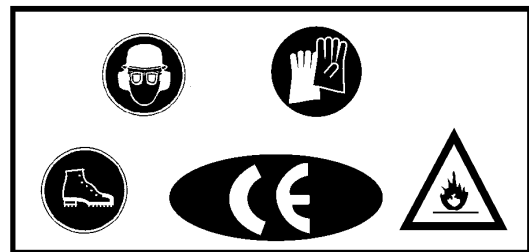

P/N DCL122

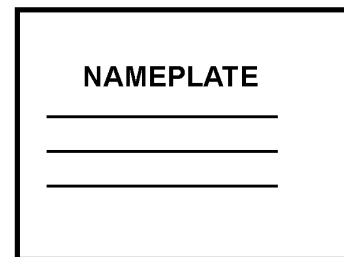

CONTACT MULTIQUIP
SERVICE DEPT.

DS-SERIES DUOSCREED — SPECIFICATIONS

TABLE 1. DUOSCREED SPECIFICATIONS	
Power Unit Model	DS-GPU
Number of Vibrations	5,500 v/min
Drive System	Flexible Shaft
Noise (Open Air)	50 dB(A)
Vibration Acceleration	1.5 m/sec ²
Operating Weight	35 lbs. (16 Kg.)
Blade Construction	Extruded Aluminum Alloy
Blade Widths	4.9, 6.2, 8.2, 9.8, 12.3, 13.9, 16.4, 18.0, 19.6 ft. (1.5, 1.9, 2.5, 3.0, 3.75, 4.25, 5.0, 5.5, 6.0 meters)
Blade Weights	Approx. 2.8 lb./ft.

TABLE 2. ENGINE SPECIFICATIONS	
Engine Make	HONDA
Engine Model	GX31-SA
Engine Type	4-Stroke OHV Gasoline Engine
Engine Weight	7.5 lbs. (3.3 Kg)
Number Of Cylinders	1
Displacement	1.9 cu. in (31cm ³)
Maximum Output	1.5 BHP/7,000 rpm
Oil Grade	SAE 10W-30
Oil Capacity	0.11 qt./(0.10 liters)
Fuel Type	Unleaded
Fuel Tank Capacity	.172 gal./(.65 liters)
Spark Plug Gap	0.024-0.028 inch (0.60-070 mm)
Spark Plug Type	CR5HSB (NGK) U16FSR-UB (DENSO)
Starting Method	Recoil Start

DS-SERIES DUOSCREED — GENERAL INFORMATION

Introduction

The Whiteman DuoScreed is a hand held vibratory screed designed to strike-off and consolidate concrete slabs. It is comprised of two major components, the power unit (gasoline engine), and the strike-off blade. **Generally this screed operates ideally in concrete with a slump of 2 inches or greater.** Its applications include patios, driveways, sidewalks and floor slabs.

Assembly

There are no tools required to assemble the DuoScreed. The power unit (engine) is connected to the blade by means of a spring-loaded clamp. Springs within the clamp assembly prevent vibration from loosening the power unit from the blade.

Handle Adjustments

The handle assembly on the DuoScreed is height adjustable for operator comfort. The handle design used on this screed allows the operator to remain upright at all times and can be quickly adjusted without any tools.

Vibratory System

The vibratory system of the DuoScreed produces low amplitude high frequency vibrations, designed to level and compact concrete. This vibratory system is mounted at an angle to transmit vibration laterally and vertically through the blade to produce a strong, dense slab.

The engine drives a two piece eccentric weight by means of a one-piece flexible shaft. This weight produces a vibratory action which simultaneously allows the DuoScreed to level the slab and consolidate the concrete beneath the surface.

Blades

The DuoScreed can utilize blades ranging in lengths from 4.9 to 19.6 feet (1.5 to 6 meters). Since different length blades will require varying amounts of vibration, the DuoScreed features adjustable eccentric weights. It is also recommended that two power units be used if 16, 18, or 20 foot blades are required.

The blade of the DuoScreed offer a unique design with two distinct edges and is manufactured from reinforced extruded aluminum alloy. A curled edge is provided for applications that allow the blade to ride on top of forms or rails. A smooth edge is provided for wetscreed applications where the machine rides entirely on concrete. Plastic end caps allow the blade to maneuver around obstructions without marring the surface.

Engine

The Whiteman DuoScreed is equipped with an Honda Model GX31SA, 1.5 HP, mini 4-cycle gasoline engine. This engine is lightweight and requires no fuel mixing.

Drive System

The Honda 1.5 HP engine drives a flexible shaft that requires no greasing. Its short one piece design runs directly to the vibrator housing and does not bend. This type of design eliminates a major source of friction and reduces the likelihood of shaft failure.

Maneuverability

End caps are provided on each side of the DuoScreed's blades to allow the screed to be easily maneuvered around pipes or obstructions.

Transport

To transport your DuoScreed simply unclamp the power unit from its base. Additionally, the handles can be folded down for storage. The power unit weights approximately 34 pounds while the blades weigh approximately 2.8 pounds per foot.

DS-SERIES DUOSCREED — COMPONENTS

Figure 2. DuoScreed Components

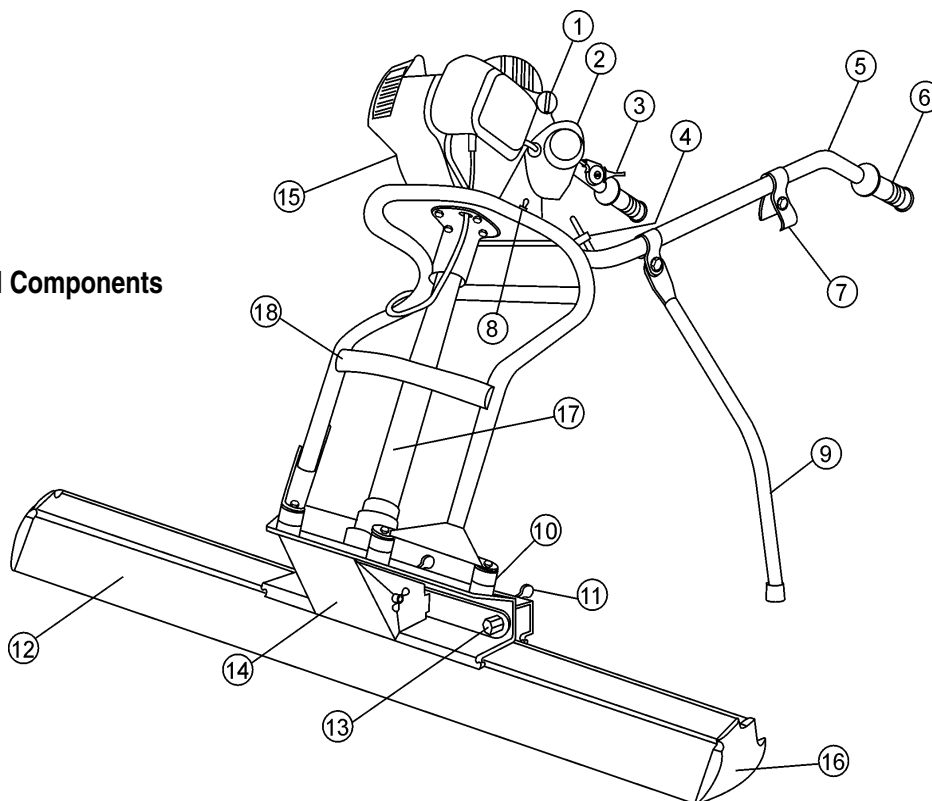

Figure 1 shows the location of the components of the DuoScreed. The function of each component is described below:

1. **Oil Cap** – Remove this cap to add engine oil.
2. **Fuel tank** – Remove the fuel tank cap to add unleaded fuel **ONLY! DO NOT** mix fuel. **DO NOT** over fill. Tank holds approximately .172 gallons (.65 liters)
3. **Throttle Control** – Move the throttle lever to the **down** position for full throttle (max RPM's), for engine idle, move the throttle lever to the **up** position.
4. **Handle Bar Adjustment Knobs** – Loosen these two knobs to adjust the handle bar to a suitable working position.
5. **Handle Bar** – Used in the steering of DuoScreed.
6. **Hand Grip** – When operating the DuoScreed use this hand grip to maneuver the machine.
7. **Support Stand Latch** – Use this latch to lock support stand in place when DuoScreed is in operation.
8. **Engine ON/OFF Switch** – Set this switch in the **ON** position to start the engine, set in the **OFF** position to stop the engine.
9. **Support Stand** – Use this stand to support the DuoScreed when not in use.
10. **Shock Mounts** – Used to absorb the vibration generated by the DuoScreed. These shock mounts minimize the transfer of vibration to the operator.
11. **Spring-Loaded Wing Nuts**– Turn these 3 spring loaded wing nuts counterclockwise to release the blade from the aluminum clamping strip, turn clockwise to secure the blade to the clamping strip.
12. **Blade** – The DuoScreed comes in various blade sizes ranging from 4.95 to 19.6 feet.
13. **Locking Nuts** – These 3 locking nuts are used in conjunction with the 3 spring loaded wing nuts which secure the blade to the aluminum clamping strip. Important! always cover the two outer nuts with the provided plastic cap. This will prevent concrete and other debris from entering the quick disconnect system.
14. **Eccentric Cover** – Encloses the adjustable eccentric weights.
15. **Gasoline Engine** – This DuoScreed uses a HONDA GX31SA engine. Refer to the **HONDA** owners manual for engine information and related topics.
16. **End Caps** – Allows the DuoScreed to be maneuvered around pipe or obstructions.
17. **Flexible Drive Shaft**– Connected to the drive shaft of the engine, provides the vibrational force for the eccentric weights.
18. **Lifting Bar**– To lift or transport the DuoScreed, grab this bar .

DS-SERIES DUOSCREED — COMPONENTS (HONDA GX31SA ENGINE)

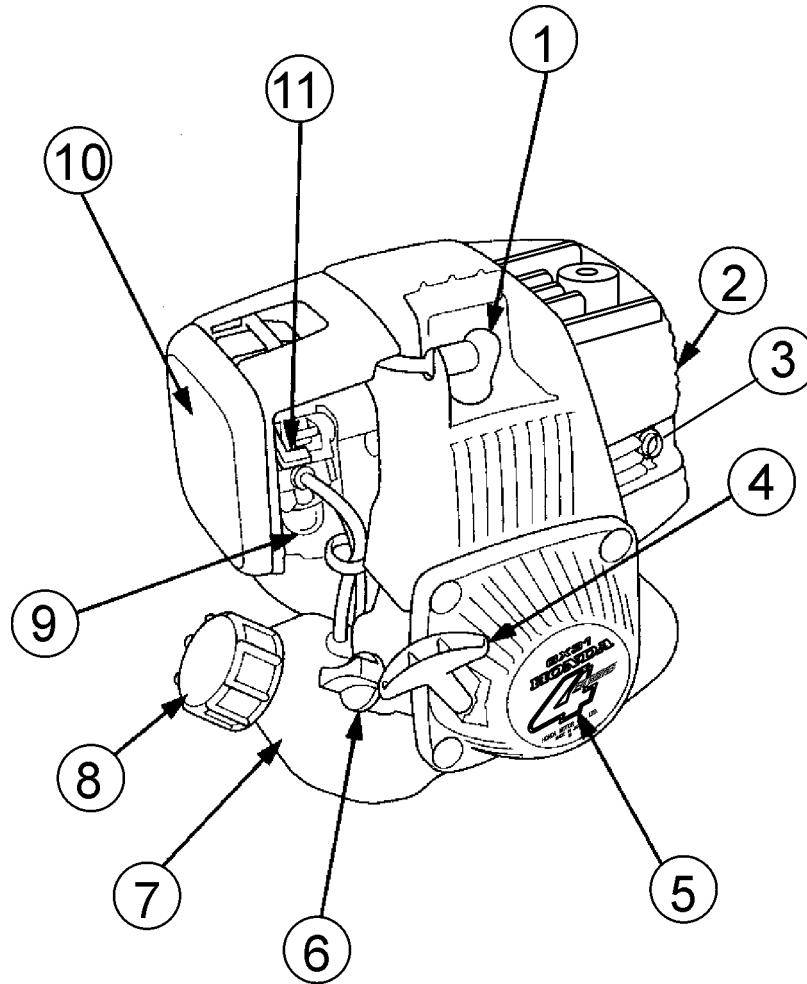

Figure 2. HONDA GX31SA Components

1. **Spark Plug** – Provides spark to the ignition system. Set spark plug gap to 0.6 - 0.7 mm (0.024 - 0.028 inch) Clean spark plug once a week.
2. **Muffler** – Used to reduce noise and emissions. **DO NOT** touch muffler while engine is running, let engine cool before performing any maintenance.
3. **Spark Arrester** – Prevents sparks from leaving the engine exhaust system, which could ignite flammable materials.
4. **Starter Grip** – Grip this handle to start engine. See engine starting section of this manual.
5. **Recoil Starter (pull rope)** – Type of engine starting method.
6. **Oil Filler Cap** – Remove this cap to add engine oil. Engine oil capacity is 0.11 quart (0.1 liters). Use SAE 10W-30.
7. **Fuel Tank** – Holds .65 liters (approximately .172 gallon) of unleaded gasoline.
8. **Fuel Filler Cap** – Remove this cap to add unleaded gasoline to the fuel tank. Make sure cap is tighten securely. **DO NOT** over fill.
9. **Priming Bulb** – Used in the starting of a cold engine or an engine that has run out of fuel. Press the priming bulb repeatedly until fuel can be seen inside the clear plastic bulb.
10. **Air Cleaner** – Prevents dirt and other debris from entering the fuel system. Release latch on side of air filter compartment to gain access to filter element.
11. **Choke Lever** – Used in the starting of a cold engine, or in cold weather conditions. The choke enriches the fuel mixture for starting a cold engine.

DS-SERIES DUOSCREED — ASSEMBLY INSTRUCTIONS

Assembly Instructions

This section will explain how to assemble the DuoScreed.

NOTE

It is recommended that you familiarize yourself with the DuoScreed's components. For assistance identifying components called out in the text, refer to the Figure 1.

1. The DuoScreed is comprised of two major components. The power unit (HONDA GX31SA Engine) and the strike-off blade. This DuoScreed is equipped with a quick disconnect system, with which the power unit can be mounted onto two aluminum clamping strips with ease.
2. The aluminum clamping strip (retaining plate) is located at the base of the power unit. This clamping strip is what holds the blade in place with the aid of three quick disconnect spring loaded wing nuts (Figure 3) that can either be tightened or loosened by hand.
3. Determine whether you will be using the DuoScreed on **forms** or as a **wet screed**. This will decide how the power unit will be mounted. If the DuoScreed will be used as a wet screed the wing nuts should be located above the smooth edge of the blade. If the DuoScreed will be used on forms (Figure 3) the wing nuts should be located above the curled edge of the blade.
4. Loosen each of the three wing nuts about 1/4 inch (8 mm). It is not necessary to completely remove the wing nuts from the aluminum clamping strip.
5. Locate the two red indicator arrows (Figure 4) on the top of the blade. The power unit should be placed squarely between the two markers.

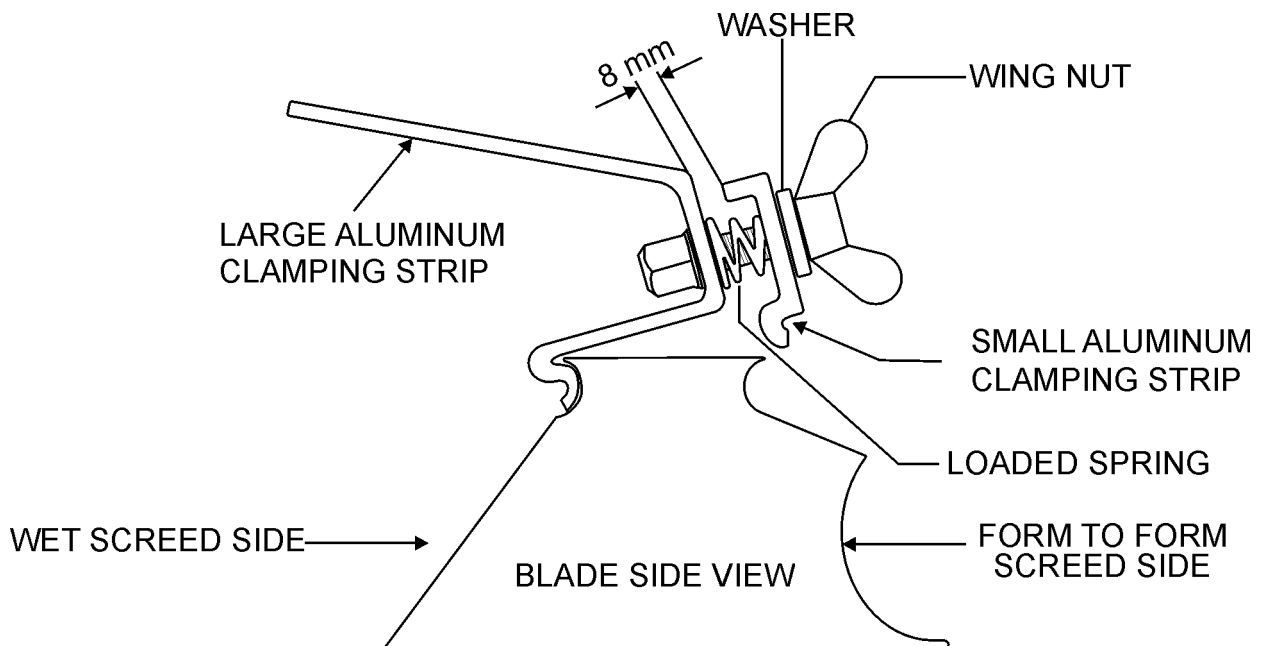

Figure 3. Blade Quick Disconnect System

DS-SERIES DUOSCREED — ASSEMBLY INSTRUCTIONS

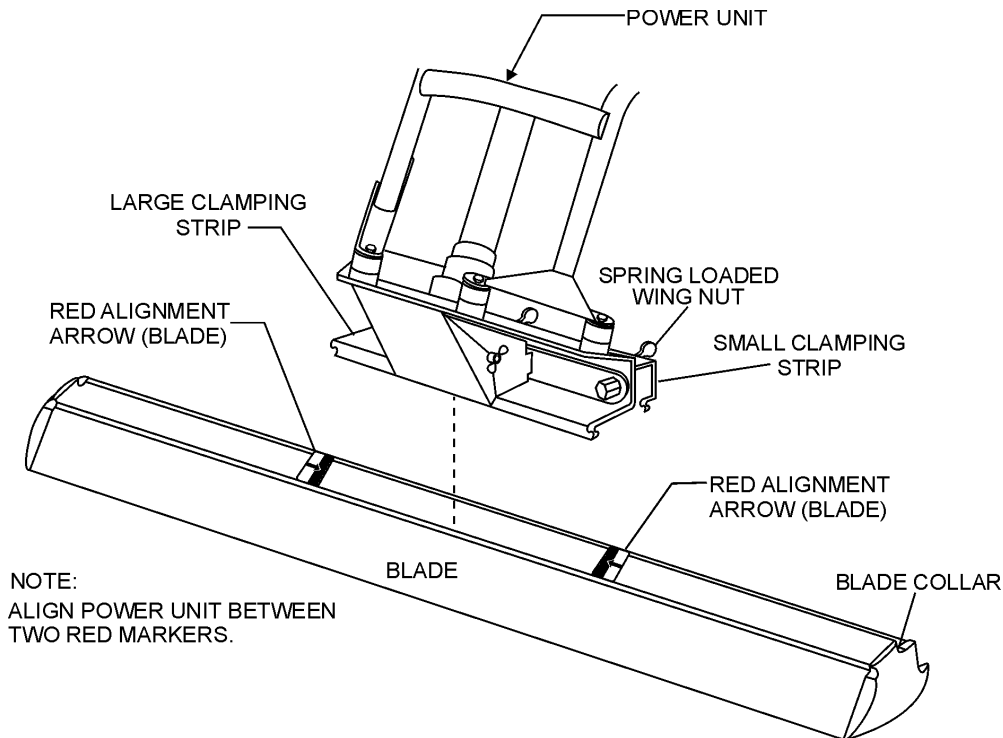

Figure 4. Blade Mounting Diagram

6. Place the front of the power unit over the blade (Figure 3) until the front of the clamp is seated within the front blade collar.
7. Ease the power unit back to allow the rear clamp to seat itself within the rear blade collar. It may be necessary to further loosen the wing nuts to allow the clamp to fit around the blade collar.
8. Securely hand tighten each of the three wing nuts. The wing nuts are spring loaded to prevent them from coming loose during operation.
9. Two handle bar adjustment knobs (Figure 5) are located at the base of the steering handle bar. Loosen these two knobs to adjust the height of the steering handle bar to a suitable working position.
10. The DuoScreed is now ready for operational use.

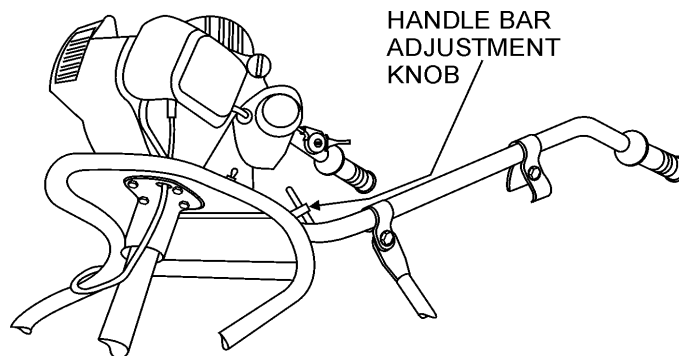

Figure 5. Handle Bar Adjustment Knob

DS-SERIES DUOSCREED — ASSEMBLY INSTRUCTIONS

Eccentric Weight Adjustment

There are two eccentric weights (Figure 6) that are supplied with the DuoScreed. These weights are located inside the eccentric weight compartment, which is located at the bottom of the unit.

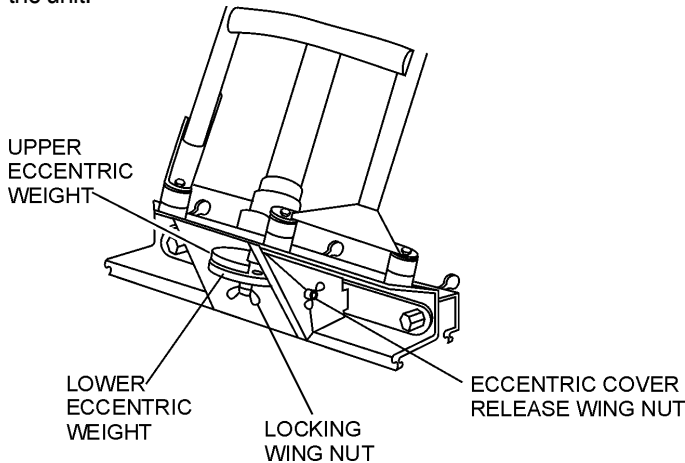

Figure 6. Eccentric Weight Location

These weights determine the amount of vibration that will travel down the blade. Depending on the type of blade that is used, will determine the position of the two eccentric weights. Reference Figure 7 in determining how your eccentric weights should be positioned.

1. To gain access to the eccentric weight compartment, loosen the two wing nuts on each side of the compartment and lift the cover.
2. Loosen the eccentric locking wing nut.
3. Use the chart in Figure 7 to determine what position your eccentric weights should be in (position 1, 2 or 3).

Example:

A 13.9 ft. (4.25 meters) blade will place the eccentric weights in position 2.

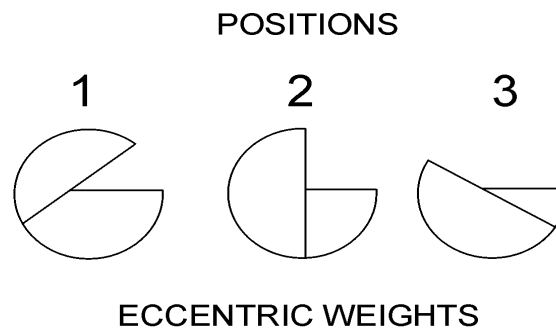

BLADE LENGTH		ECCENTRIC WEIGHT POSITION
FEET	METERS	
4.9	1.5	1
6.2	1.9	1
8.2	2.5	1
9.5	3.0	1
12.3	3.75	2
13.9	4.25	2
16.4	5.00	3*
18.0	5.50	3*
19.6	6.00	3*

*TWO POWER UNITS REQUIRED PER BLADE

Figure 7. Eccentric Weight Positions

DS-SERIES DUOSCREED — STARTING

Engine Pre-Check

1. Fill the fuel tank (Figure 8) with unleaded gasoline. **DO NOT** over fill. Topping-off to filler port is dangerous, as it tends to spill fuel. Wipe up any spilled fuel immediately.

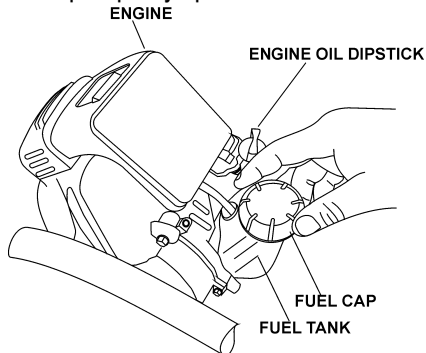

Figure 8. Fuel Tank

1. Place the engine in a level position.
2. Check the engine oil level by unscrewing the engine oil dip stick (Figure 9) from its holder.
3. If oil is not observed at the edge of the oil filler hole, fill with oil until oil is present at edge of oil filler hole. Remember to add oil slowly to avoid overflowing, as the engine oil tank capacity is small.

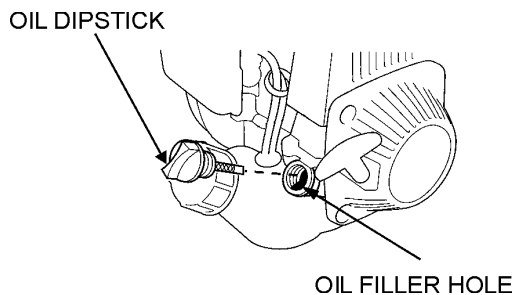

Figure 9. Engine Oil Dipstick/Oil Filler Hole

4. Reinstall the engine oil dipstick securely.

Starting The Engine

1. To start a cold engine, move the choke lever (Figure 10) to the **CLOSED** position. If restarting a warm engine leave the choke lever in the **OPEN** position.

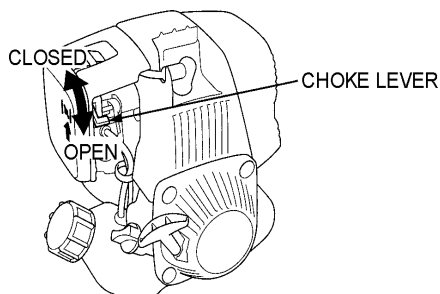

Figure 10. Choke Lever

2. Press the priming bulb (Figure 11) repeatedly until fuel can be seen inside the clear plastic bulb.

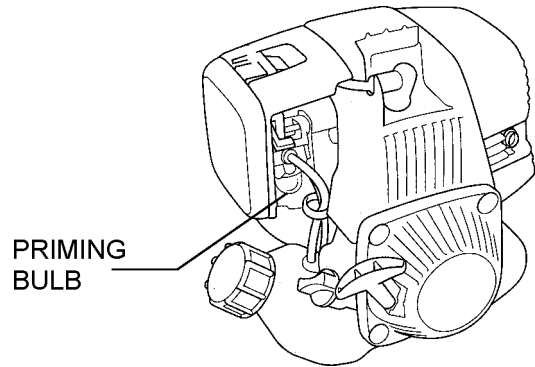

Figure 11. Priming Bulb Location

3. Set the engine ON/OFF switch (Figure 12) to the **ON** position.

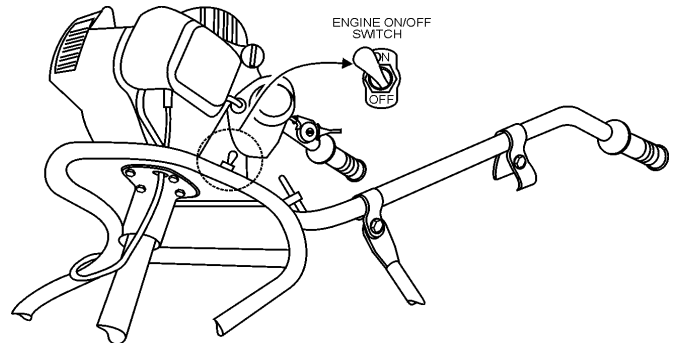

Figure 12. Engine ON/OFF Switch

4. Pull the starter rope (Figure 13) lightly until you feel resistance, the pull briskly. Return the starter rope gently.

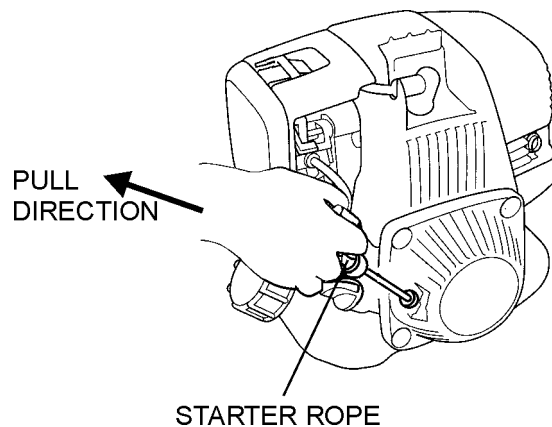

Figure 13. Engine Starter Rope

5. Once the engine has started, allow it to idle for 3 to 5 minutes.

DS-SERIES DUOSCREED — APPLICATION/OPERATION

Application/Operation

1. Before placing the DuoScreed in concrete for screeding, it is a good idea to apply **form oil** to the blade and all frame parts that may come in contact with the concrete. This form oil will become useful when cleaning the DuoScreed. Make sure to saturate the unit with a good amount of form oil.
2. Prepare a grid of #5 rebar pins (Figure 14) equally spaced approximately every 9 to 11 feet. If a 10 ft. screed blade is going to be used space the grade pins every 9 feet, if a 12 ft. screed blade is required, space the grade pins every 11 ft. Make sure to drive the pins deeply into the ground.
3. Use a **string line** or **laser** to set the pins to grade (height). The grade should be to the top of the grade pins. Remember, before any concrete is to be poured, make sure that the top of the pins are dead on grade.
4. Once all the grade pins have been placed correctly and are dead on grade, concrete can then be poured on top of grade pins.
5. Level, and form the concrete as close as possible to grade. Mark the top of each pin so that its exact location will be known. Use a hand trowel to float the edges and plumbing grade pins.
6. If chalk lines are used for grade against forms, walls or existing concrete, float out the grade with a hand float along the edge.
7. Two workers will be required to assist the DuoScreed operator when making the 12-18 concrete bases, one on each side. These workers will rake the concrete in toward the center of the DuoScreed away from the bases to avoid changing base elevation.

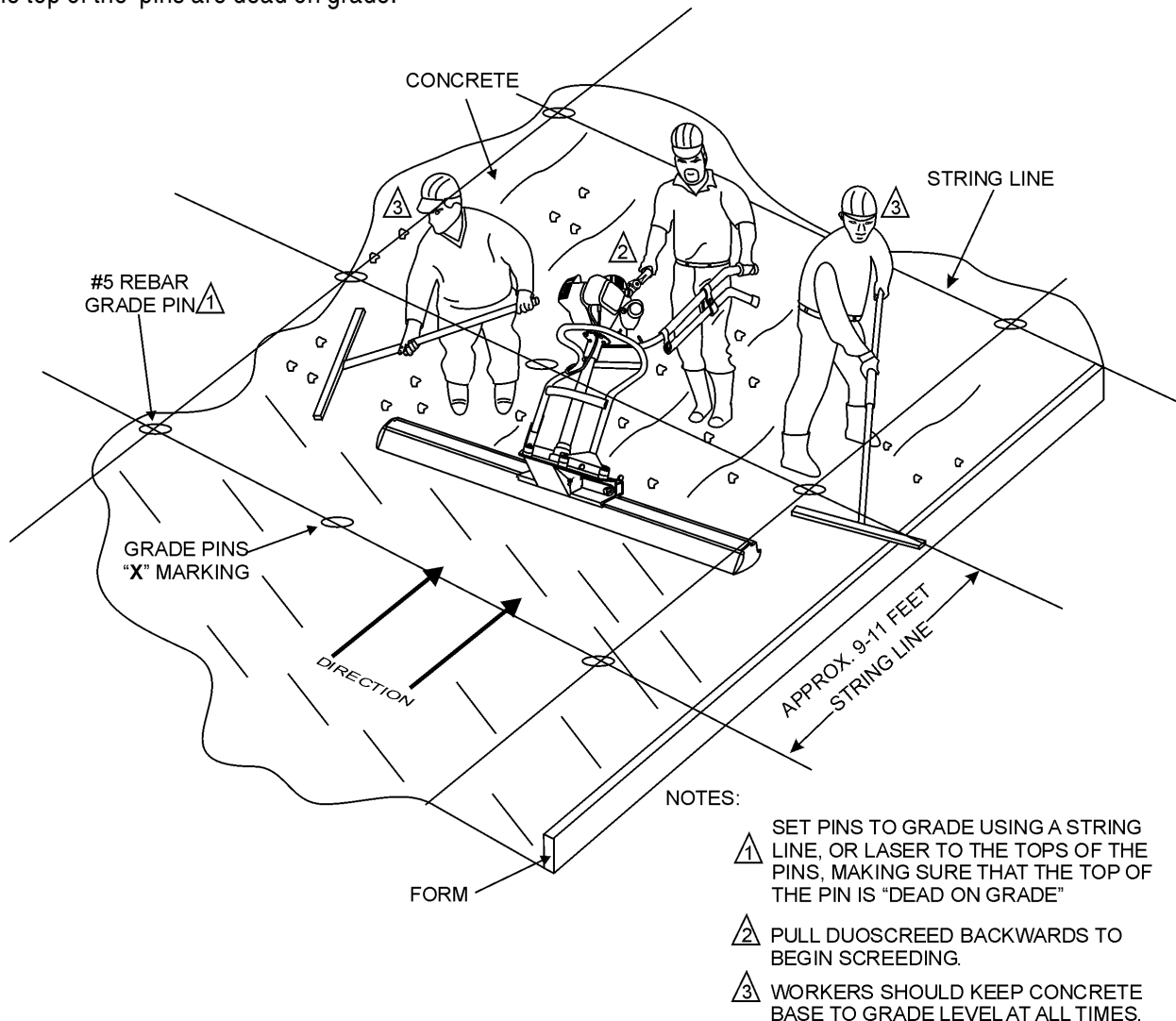

Figure 14. DuoScreed On Forms and Grade Pins

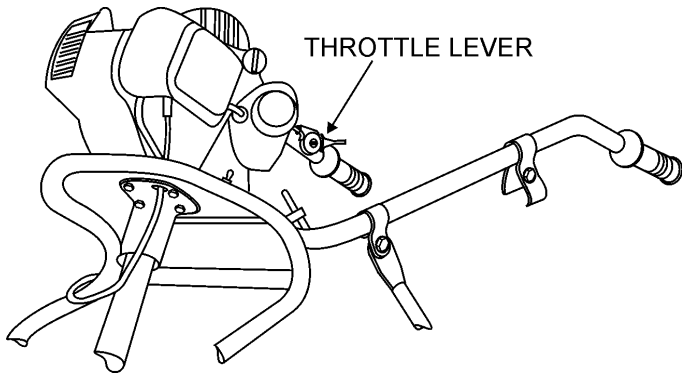

Figure 15. Throttle Lever

NOTE

Before placing the DuoScreed in concrete, make certain the unit has been set up (blade) for **wet screeding**. This can be verified by observing that the operator's toes are pointing towards the smooth side of the blade (Figure 3), from the operators's position (handle bars).

8. Set the DuoScreed blade down in the concrete base in the **left** most corner of the grid between the two grade pins as shown in Figure 16. Adjust the DuoScreed's handle bar to a height where the operators is not bending over, but standing upright with arms extended forward.
9. To begin screeding move the engine throttle lever (Figure 15) midway between idle and full throttle. Notice that the DuoScreed's vibration will cause the blade to sink into the concrete base until it touches the top of the grade pins
10. Pull the DuoScreed from the edge of the grid's **top left** corner, horizontally toward the **center**. Notice that as the DuoScreed passes over the grade pins a small circle of concrete around the grade pins will appear. This indicates that the DuoScreed has vibrated the grade pin, and that the operators is **dead on grade**.
11. Keep the DuoScreed blade level and create a level base between 12-18 inches wide.
12. After a complete pass over the first set of grade pins has been made, remove the DuoScreed from the concrete base and position it over the second set of grade pins (Figure 16), overlapping the first set of grade pins between 12-18 inches. Repete this process until all **left** edge grade pins have a level base between 12-18 inches wide.
13. Repeat steps 9 through 12 pulling the DuoScreed from the edge of the grid's **top right** corner, horizontally toward the center.
14. Remember to build the bases in long parallel strips across the pins and on the hand floated edges and against plumbing or other outs, leaving the long unfinished areas about 8 or 9 feet wide. Once the bases are built, the workers can more accurately shape the concrete to grade.
15. When **all** the bases have been completed, the operator and his two workers can begin to work down the long parallel unfinished 8 to 9 foot wide middle portions. When moving the DuoScreed down the middle portions, the ends of the DuoScreed blade should be resting on the bases, and the leading edge of the blade should be approximately 1/8 to 1/4 inch above each base depending on the slump and condition of the concrete. Have workers adjust the concrete along the face of the DuoScreed's blade to assure that the base is level with no high or low areas ahead of the blade.
16. Keep the engine throttle between 1/2 to 2/3 of full speed, if necessary readjust the DuoScreed's vibration to meet the condition of the concrete. Remember to move rapidly and watch both ends of the blade to assure that the blade remains 1/8 to 1/4 of an inch above the concrete base. Always keep the workers alert for concrete height changes.

Shut-Down

1. **NEVER** stop the engine suddenly while running at high speed.
2. Move the engine **throttle lever** (Figure 15) to the low speed position (idle).
3. Set the engine ON/OFF switch (Figure 12) to the **OFF** position.
4. Remove the DuoScreed from the slab surface.

Cleaning

1. Allow the engine to **cool** before cleaning. When the engine has cooled, use a damp and a mild detergent to remove all concrete and foreign debris. **DO NOT** spay the engine with water.
2. To remove all concrete and foreign debris from the DuoScreed, wash the DuoScreed's blade and frame using water and a mild detergent. Remember, if form oil was applied before the machine was placed in concrete, the cleanup will be much easier.

DS-SERIES DUOSCREED — APPLICATION/OPERATION

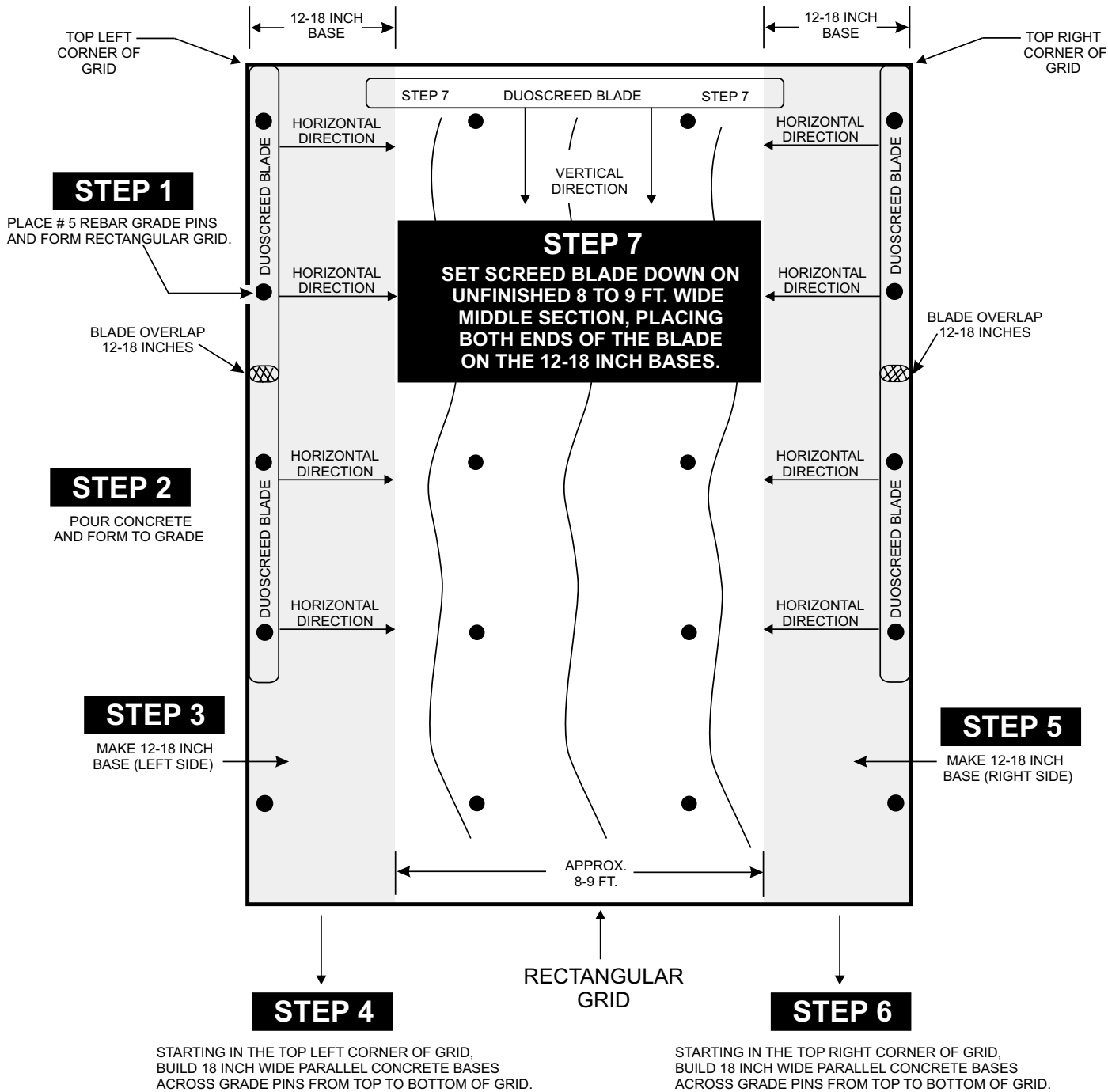

Figure 16. DuoScreed Wet Screeding Application

DS-SERIES DUOSCREED — APPLICATION/OPERATION

Important Tips to Remember

- Do not allow the engine to run out of fuel as this may cause problems with starting. Always maintain an extra supply of fuel on the job site.
- Always keep the DuoScreed moving backwards during operation. Allowing the DuoScreed to vibrate in the same location for too long will cause it to sink into the concrete.
- When using the DuoScreed with low slump (dry) concrete do not attempt to walk it quickly across the slab. Walk slowly to allow the vibratory action to consolidate and level the slab surface. When using the DuoScreed with high slump (wet) concrete you will be able to walk the machine across the slab at a faster pace.
- In applications where the DuoScreed is being used as a wet screed it is recommended that grade or height of the concrete slab be adjusted with a laser device.
- Proper vibratory force is essential to producing a *level, hard, durable* slab. If the DuoScreed is vibrating too strongly the ***eccentric weights*** will require adjustment. Refer to the troubleshooting section of this manual.
- When screeding using forms or rails, always size your screed blade appropriately for the job. It is best to have the blade extend beyond the forms, by about 6-inches on each side.
- When screeding make sure the blade is kept straight. **DO NOT** let blade turn.
- **DO NOT** run the DuoScreed with one part of the blade on forms and the other on base. The blade must either be placed on forms or float (wet screeding), but not a combination of the two techniques.
- **DO NOT** stand in the concrete with the engine throttle engaged. This will cause the DuoScreed to sink.
- If the concrete appears too wavy, you are moving too slowly, increase your backing-up speed.
- Always keep the workers back far enough too allow the operator to see the cutting face of the blade as it rides on the wet screed base.
- The operator should keep the screed blade about 1/8 to 1/4 inch above the concrete base at all times.
- Should the DuoScreed stick to the wet concrete slab, **DO NOT** attempt to lift it. Quickly increase engine rpm's while pushing forward on the handles to free the machine.

DS-SERIES DUOSCREED — MAINTENANCE

Maintenance

CAUTION:



DO NOT clean the DuoScreed with a **pressure washer**.

1. **NEVER** clean the DuoScreed with the engine running.
2. Allow the engine to cool down before cleaning.

NOTE

DO NOT allow concrete to **harden** on the DuoScreed. Wipe all concrete off the chrome frame and any other parts including the engine of the DuoScreed.

3. Use a low pressure water hose, soft brush, wiping cloth and a mild cleaning detergent and remove all concrete from the DuoScreed. Be careful not to get excessive amounts of water in the engine compartment.
4. Keep the drive unit free from grease, dirt and grime as this can effect the performance of your DuoScreed

30 - Day Storage Procedure

For storage of the DuoScreed for over 30 days, the following is required:

- Drain the fuel tank completely.
- Run the engine until the fuel in the injection system is completely consumed.
- Completely drain used oil from the engine crankcase and fill with fresh clean oil, then follow the procedures described in the engine manual for engine storage.
- Cover DuoScreed and engine with plastic covering or equivalent and store in a clean, dry place.

Table 3. Engine Maintenance Schedule

DESCRIPTION (3)	OPERATION	BEFORE	FIRST MONTH OR 10 HRS.	EVERY 3 MONTHS OR 25 HRS.	EVERY 6 MONTHS OR 50 HRS.	EVERY YEAR OR 100 HRS.	EVERY 2 YEARS OR 200 HRS.
Engine Oil	CHECK	X					
	CHANGE		X				
Air Cleaner	CHECK	X					
	CHANGE			X (1)			
All Nuts & Bolts	Re-tighten If Necessary	X					
Spark Plug	CHECK-CLEAN				X		
	REPLACE						X
Cooling Fins	CHECK				X		
Spark Arrester	CLEAN					X	
Fuel Tank	CLEAN					X	
Fuel Filter	CHECK					X	
Clutch Shoes	CHECK				X (2)		
Idle Speed	CHECK-ADJUST					X (2)	
Valve Clearance	CHECK-ADJUST						X (2)
Fuel lines	CHECK	Every 2 years (replace if necessary) (2)					

(1) Service more frequently when used in **DUSTY** areas.

(2) These items should be serviced by your servc dealer, unless you have the proper tools and are mechanically proficient. Refer to the HONDA shop Manual for service procedures

(3) For commercial use, log hours of operation to determine proper maintenance intervals.

DS-SERIES DUOSCREED — MAINTENANCE

Air Cleaner

1. The air cleaner element should be cleaned because a clogged air cleaner can cause poor engine starting, lack of power and shorten engine life substantially.
2. Before opening the air cleaner compartment, wipe any dirt or foreign matter from the air cleaner body and cover, using a moist cloth. Be careful to prevent dirt from entering the carburetor
3. Press the latch tab on the top of the air cleaner cover (Figure 16), and remove the cover. Check the filter to be sure that it is clean and in good condition.

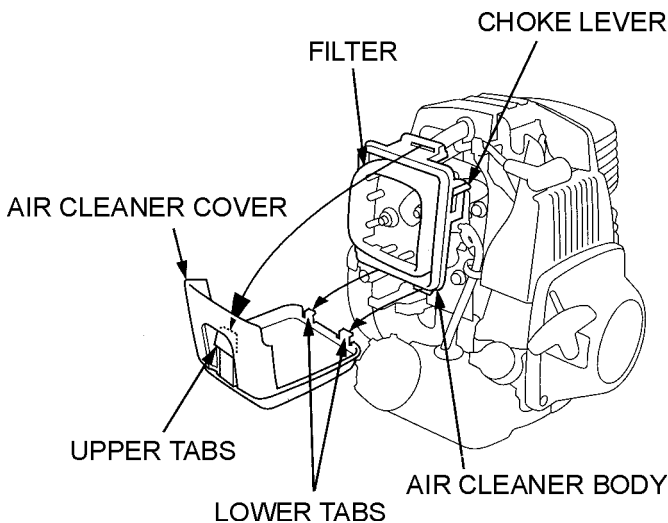

Figure 16. Air Cleaner

Spark Plug

1. Make sure the engine is off and cool.
2. Disconnect the spark plug cap (Figure 17), and remove any dirt from around the spark plug area.

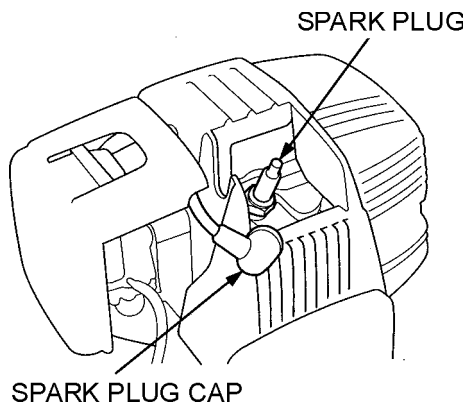

Figure 17. Spark Plug Removal

3. Remove the spark plug with 5/8-inch wrench.
4. Inspect the spark plug. Replace it if the electrodes are worn, or if the insulator is cracked or chipped. Clean the spark plug with a wire brush if you are going to reuse it.
5. Set the spark plug gap (Figure 18) using a suitable gauge. The gap should be between 0.024-0.028 inch (0.60-0.70 mm).

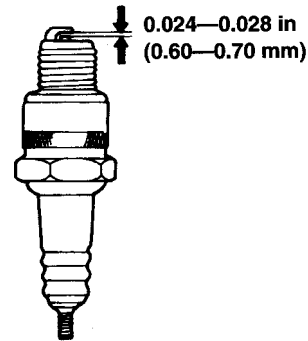

Figure 18. Spark Plug Gap

6. Carefully install the spark plug by hand to avoid cross threading, then tighten
7. Attach spark plug cap.

DS-SERIES DUOSCREED — TROUBLESHOOTING

TABLE 4. DUOSCREED TROUBLESHOOTING

SYMPTOM	POSSIBLE CAUSE	SOLUTION
Vibrates insufficient and as a result the concrete floor cannot be leveled and smoothed in the proper way.	The centrifugal force of the vibrator is set too low?	Adjust the eccentric weights per Figure 7 or increase engine speed.
	There is excessive amounts of concrete along the leading edge of the blade?	Remove the excessive concrete from the blade.
	The chosen width of the blade is too large?	Work with a smaller blade Remember maximum width is 20 ft. (2 engines)
The DuoScreed when used as a form-to-form screed vibrates too much and does not travel smoothly across the rail supports.	Selected blade and eccentric weights do not match?	Adjust eccentric weights to match selected blade width. Reference Figure 7.
Concrete looks "WAVY" as the screed blade passes over it.	Operator moving too slowly?	Walk backwards at a faster pace.
	Too much vibration for the type of concrete?	Reduce engine speed and walk backwards at a faster pace.
Leaving HIGH or LOW spots during wet screeding.	Concrete too high or low on one side?	Have workers shape the concrete close as possible to grade. Maintain about 1 inch of concrete across the front of the blade at all times.
Blade digs into wet concrete.	Is blade positioned correctly?	Each end of the blade must ride on the same surface. Either each end of the blade rides on forms or concrete (wet screed) not both.

DS-SERIES DUOSCREED — TROUBLESHOOTING

TABLE 5. ENGINE TROUBLESHOOTING

SYMPTOM	POSSIBLE CAUSE	SOLUTION
Difficult to start, "fuel is available, but no SPARK at spark plug".	Spark plug bridging?	Check gap, insulation or replace spark plug.
	Carbon deposit on spark plug?	Clean or replace spark plug.
	Short circuit due to deficient spark plug insulation?	Check spark plug insulation, replace if worn.
	Improper spark plug gap?	Set to proper gap.
Difficult to start, "fuel is available, and SPARK is present at the spark plug".	ON/OFF switch is shorted?	Check switch wiring, replace switch.
	Ignition coil defective?	Replace ignition coil.
	Improper spark gap, points dirty?	Set correct spark gap and clean points.
	Condenser insulation worn or short circuiting?	Replace condenser.
	Spark plug wire broken or short circuiting?	Replace defective spark plug wiring.
Difficult to start, "fuel is available, spark is present and compression is normal"	Wrong fuel type?	Flush fuel system, and replace with correct type of fuel.
	Water or dust in fuel system?	Flush fuel system.
	Air cleaner dirty?	Clean or replace air cleaner.
	Choke Open?	Close Choke.
Difficult to start, "fuel is available, spark is present and compression is low"	Suction/exhaust valve stuck or protruded?	Re-seat valves.
	Piston ring and/or cylinder worn?	Replace piston rings and or piston.
	Cylinder head and/or spark plug not tightened properly?	Torque cylinder head bolts and spark plug.
	Head gasket and/or spark plug gasket damaged?	Replace head and spark plug gaskets.
No fuel present inside priming bulb.	Fuel not available in fuel tank?	Fill with correct type of fuel.
	Fuel filter clogged?	Replace fuel filter.
	Fuel tank cap breather hole clogged?	Clean or replace fuel tank cap.
	Air in fuel line?	Bleed fuel line.

DUOSCREEN — EXPLANATION OF CODE IN REMARKS COLUMN

How to read the marks and remarks used in this parts book.

Items Found In the “Remarks” Column

Serial Numbers-Where indicated, this indicates a serial number range (inclusive) where a particular part is used.

Model Number-Where indicated, this shows that the corresponding part is utilized only with this specific model number or model number variant.

Items Found In the “Items Number” Column

All parts with same symbol in the number column, *, #, +, %, or ■, belong to the same assembly or kit.

NOTE

If more than one of the same reference number is listed, the last one listed indicates newest (or latest) part available.

NOTE

The contents of this catalog are subject to change without notice.

DUOSCREEN — SUGGESTED SPARE PARTS

DUOSCREEN 1 TO 3 UNITS WITH HONDA GX31SA ENGINE

1 to 3 Units

Qty.....	P/N.....	Description
2	BF2648	HANDLE GRIP
1	BF2647	THROTTLE GRIP
2	BF2645	THROTTLE CABLE
1	BF2621	FLEXIBLE SHAFT
1	BF2609	ECCENTRIC COVER
3	BF2607	COMPRESSION SPRING
1	BF2605	ALUMINUM CLAMPING STRIP
3	BF0176	WASHER
3	BF2606	CLAMP
1	BF2643	STOP SWITCH
3	BF0325	WING NUT M6X12
3	9805655757	SPARK PLUG
3	17211ZM3000	ELEMENT AIR
1	15620ZM3003	CAP, OIL FILLER
1	28400ZM3003ZA	RECOIL STARTER ASSY.

NOTE

Part numbers on this Suggested Spare Parts List may supercede/replace the P/N shown in the text pages of this book.

DS-SERIES DUOSCREED — MAIN ASSY.

DUO SCREED MAIN ASSY.

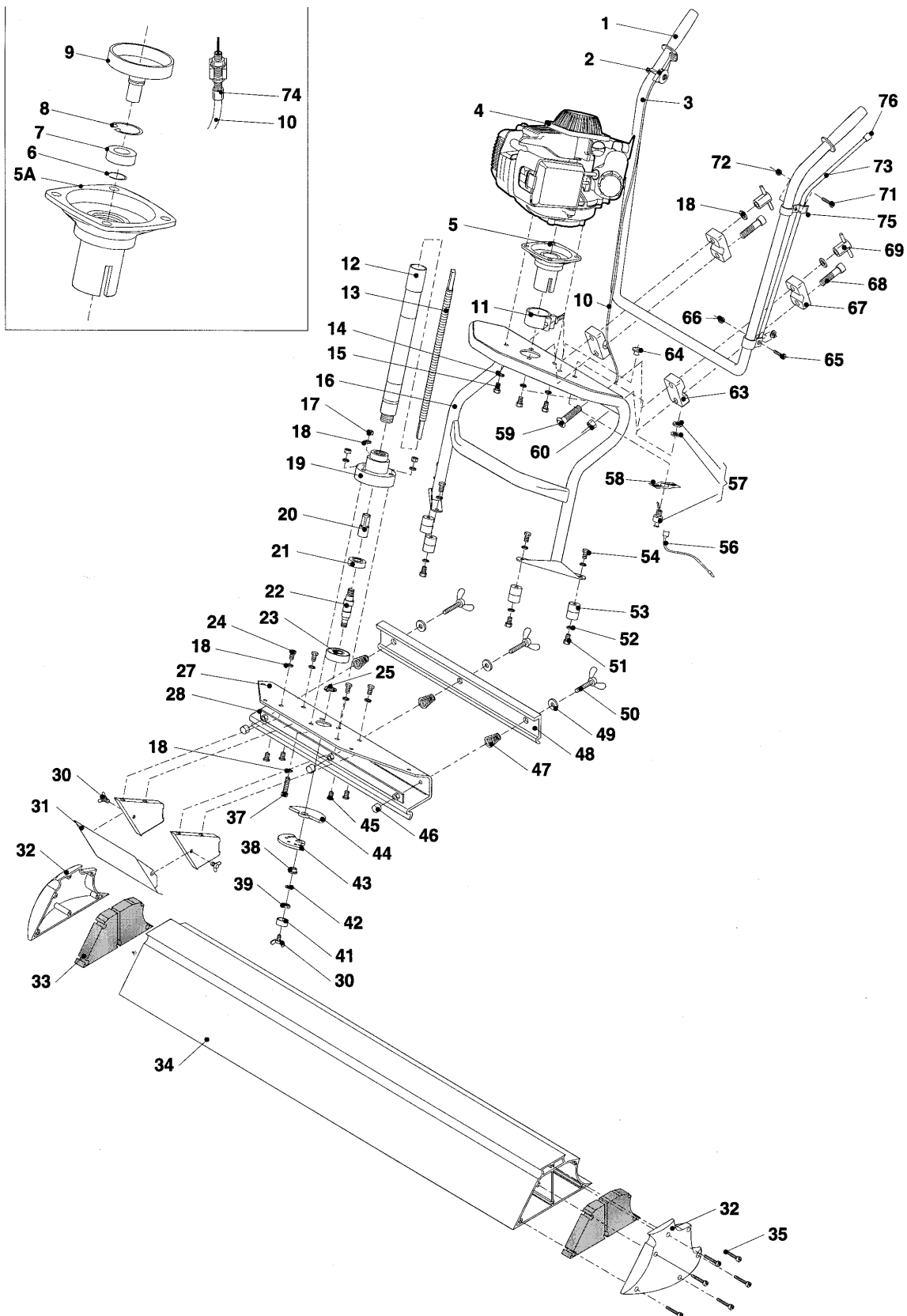

DS-SERIES DUOSCREED — MAIN ASSY.

DUO SCREED MAIN ASSY.

<u>NO.</u>	<u>PART NO.</u>	<u>PART NAME</u>	<u>QTY.</u>	<u>REMARKS</u>
1	BF2648	HANDLE GRIP	2	
2	BF2647	THROTTLE HANDLE	1	
3	BF2633	UPPER OPERATING HANDLE	1	
4	BF2640A	ENGINE HONDA GX 31SA (USA)	1	
5	BF2641	CENTRIFUGAL CLUTCH HOUSING COMPLETE (EXCLUDING CLAMP 11)	1	
5A	BF2641	CENTRIFUGAL CLUTCH HOUSING WITH ALUMINUM RING	1	
6	BF0201	RETAINING RING 17 X 1 MM IN CENTRIFUGAL HOUSING	1	
7	BF2642C	BEARING IN CENTRIFUGAL HOUSING	1	
8	BF0205	RETAING RING (BIG)	1	
9	BF2642	CENTRIFUGAL DRUM	1	
10	BF2645	THROTTLE ASM. CABLE 100CMS.	1	
11	BF2626	CENTRIFUGAL HOUSING CLAMP	1	
12	BF2625	RUBBER HOSE WITH CONNECTORS	1	
13	BF2621	FLEXIBLE SHAFT	1	
14	BF0178	SPRING WASHER M6 TYPE B	4	
15	BF0165	SOCKET HEAD BOLT M6 X 25	4	
16	BF2632	LOWER OPERATING HANDLE	1	
17	BF0101	SELF LOCKING NUT M8	3	
18	BF0155	FLAT WASHER M8	8	
19	BF2611	ECCENTRIC HOUSING	1	
20	BF1100000008	COUPLING DRIVE PIN	1	
21	BF2619	BEARING (SMALL)	1	
22	BF2612	ECCENTRIC SHAFT	1	
23	BF2314	BEARING (BIG)	1	
24	BF0125	TAP BOLT M8 X 16	4	
25	BF0201	RETAINING RING 17 X 1MM	1	
27	BF2604	ECCENTRIC ASSEMBLY PLATE	1	
28	BF2610	STRIP & NUTS FOR ALUMINUM CLAMP	1	
30	BF0325	WING NUT M6 X 12	3	
31	BF2609	ECCENTRIC COVER	1	
32	BF2602	ENDCAPS SET	1	
33	BF2602A	ALUMINUM BLADE SEALS SET (1 SIDE)	1	
34		DUOSCREED BLADE 1.5 MTR. - 5 FT.	1	ACCESSORY ITEM ORDER
		DUOSCREED BLADE 1.9 MTR.- 6 FT.	1	FROM UNIT SALES DEPT.
		DUOSCREED BLADE 2.5 MTR. - 8 FT.	1	"
		DUOSCREED BLADE 3.0 MTR. - 10 FT.	1	"
		DUOSCREED BLADE 3.75 MTR. - 12 FT.	1	"
		DUOSCREED BLADE 4.25 MTR. - 14 FT.	1	"
		DUOSCREED BLADE 5.0 MTR. - 16 FT.	1	"
		DUOSCREED BLADE 5.50 MTR. - 18 FT.	1	"
		DUOSCREED BLADE 6.0 MTR. - 20 FT.	1	"

DS-SERIES DUOSCREED — MAIN ASSY.

DUO SCREED MAIN ASSY.

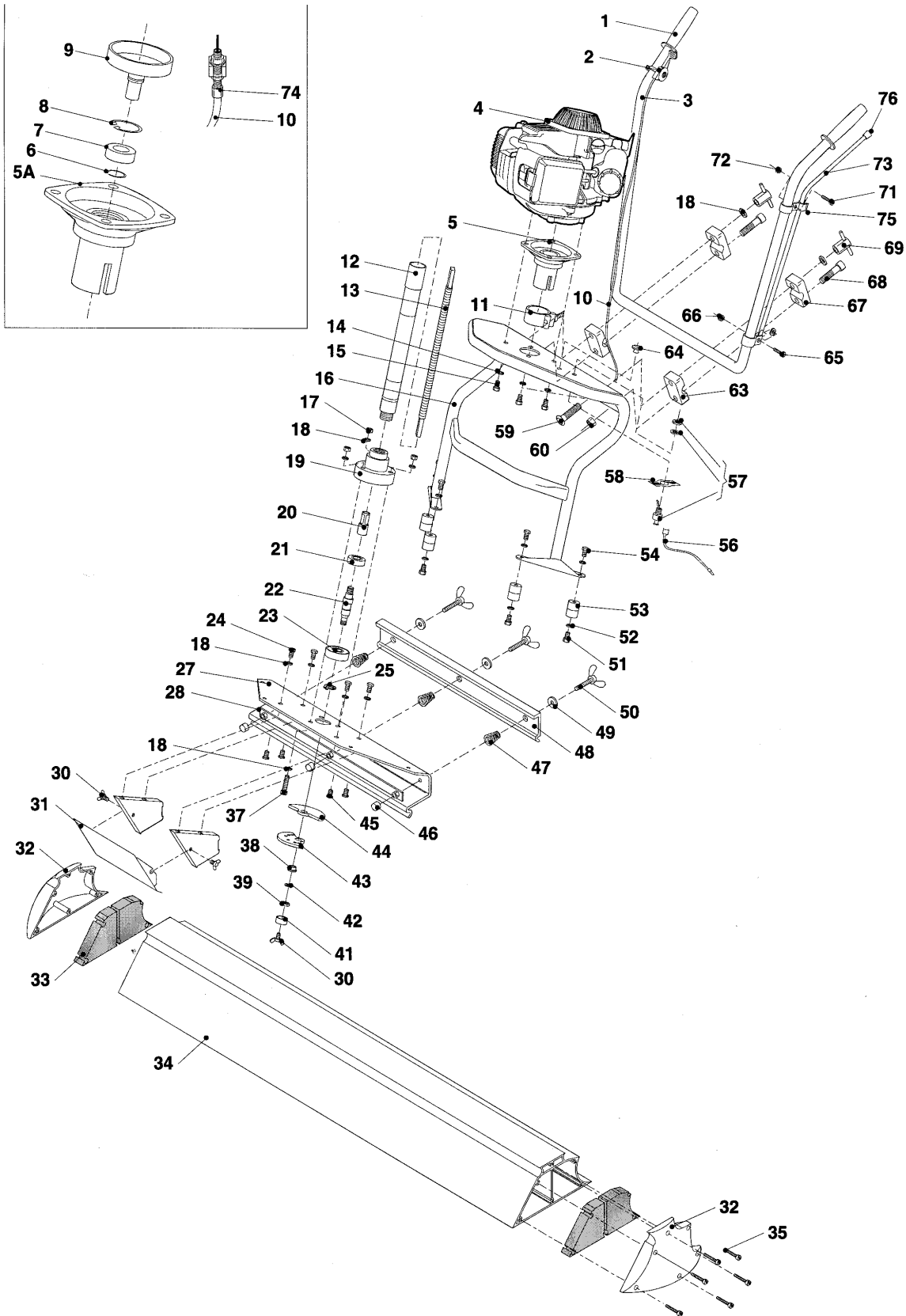

DS-SERIES DUOSCREED — MAIN ASSY.

DUO SCREED MAIN ASSY.

<u>NO.</u>	<u>PART NO.</u>	<u>PART NAME</u>	<u>QTY.</u>	<u>REMARKS</u>
35	BF0277	SELF TAPPING SCREW M5 X 20	12	
37	BF0129	TAP BOLT M8 X 40	3	
38	BF2614	ECCENTRIC HINGE BUSHING	1	
39	BF0177	NUT M12 (FINE)	1	
41	BF2613	ECCENTRIC CLAMPING BUSH	1	
42	BF0175	RETAINING RING M12	1	
43	BF2615A	ECCENTRIC PLATE (SMALL)	1	
44	BF2615B	ECCENTRIC PLATE (BIG)	1	
45	BF0229	COUNTERSUNK HEADSCREW 8.8 M8X20	4	
46	BF2617	PLASTIC PROTECTION CAP M12	3	
47	BF2607	COMPRESSION SPRING FOR CLAMPING STRIP	3	
48	BF2605	ALUMINUM CLAMPING STRIP	1	
49	BF0176	WASHER M12X6	3	
50	BF2606	CLAMP FOR CLAMPING STRIP	3	
51	BF0285	TAP BOLT M8X12	3	
52	BF0212	INTERNAL TOOTHING RING M8	8	
53	BF0056	RUBBER BUFFER 30X30 M8	4	
54	BF0124	TAP BOLT M8X10	4	
56	BF2643A	EARTH WIRE FOR STOP SWITCH	1	
57	BF2643	STOPSWITCH	1	INCLUDES ITEMS W/*
58*		ON-OFF INDICATION PLATE	1	
59	BF0283	CARRIAGE BOLT M8X50	2	
60	BF0089	SELF LOCKING FLANGE NUT M6	2	
63	BF2635	LOWER ALUMINUM CLAMP	2	
64	BF2649	RUBBER SLEEVE	1	
65	BF0258	TAP BOLT M6X20	1	
66	BF0100	SELF LOCKING NUT	1	
67	BF2635A	UPPER ALUMINUM CLAMP	2	
68	BF0284	SOCKET HEAD BOLT M6X40	2	
69	BF2636	CLAMP FOR HEIGHT ADJUSTMENT	2	
71	BF0261	SCREW M5X12	1	
72	BF0099	SELF LOCKING NUT M5	1	
73	BF2637	SUPPORTING LEG	1	
74	BF2644	GAS THROTTLE ADJUSTMENT BOLT	1	
75	BF2639	CLAMP FOR SUPPORTING LEG	1	
76	BF2634	RUBBER PROTECTION CAP FOR SUPPORT LEG	1	

DS-SERIES DUOSCREED — NAME PLATE AND DECALS

NAME PLATE AND DECALS.

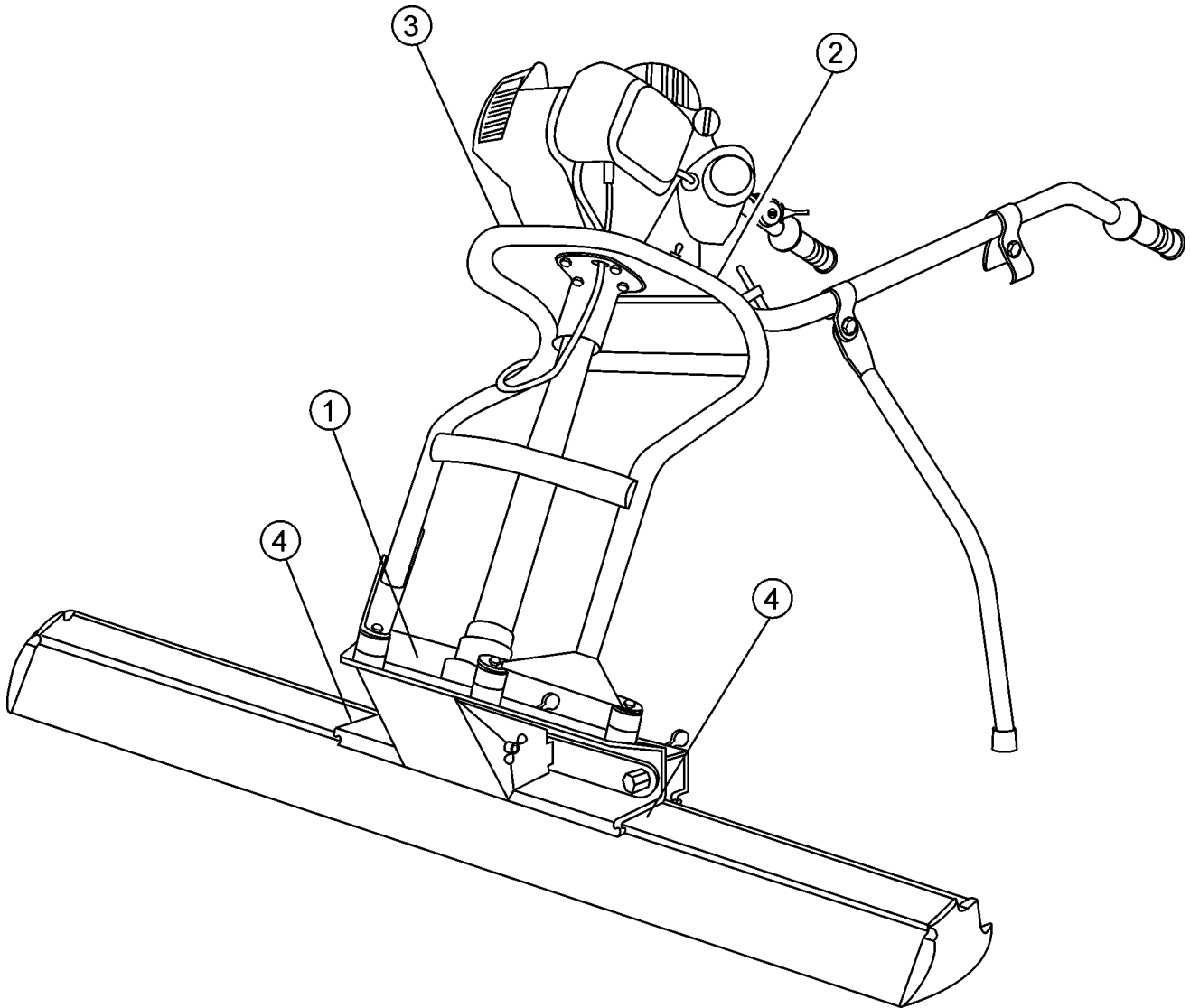

DS-SERIES DUOSCREEN — NAME PLATE AND DECALS

NAME PLATE AND DECALS.

<u>NO</u>	<u>PART NO</u>	<u>PART NAME</u>	<u>QTY.</u>	<u>REMARKS</u>
1*	DCL121	DECAL, PRESSURE HOSE	1	
2*	DCL122	DECAL, SAFETY	1	
3		PLATE, SERIAL NO.	1 CONTACT MQ SERVICE DEPT. W/MODEL & S/N
4*	DCL140	DECAL, ALIGNMENT ARROWS	2	
	DCLDS-SERIES	KIT, DECAL	1 INCLUDES ITEMS W/*

SEE DECAL ILLUSTRATIONS ON PAGE 7.

HONDA GX31SA ENGINE — CRANKCASE ASSY.

CRANKCASE ASSY.

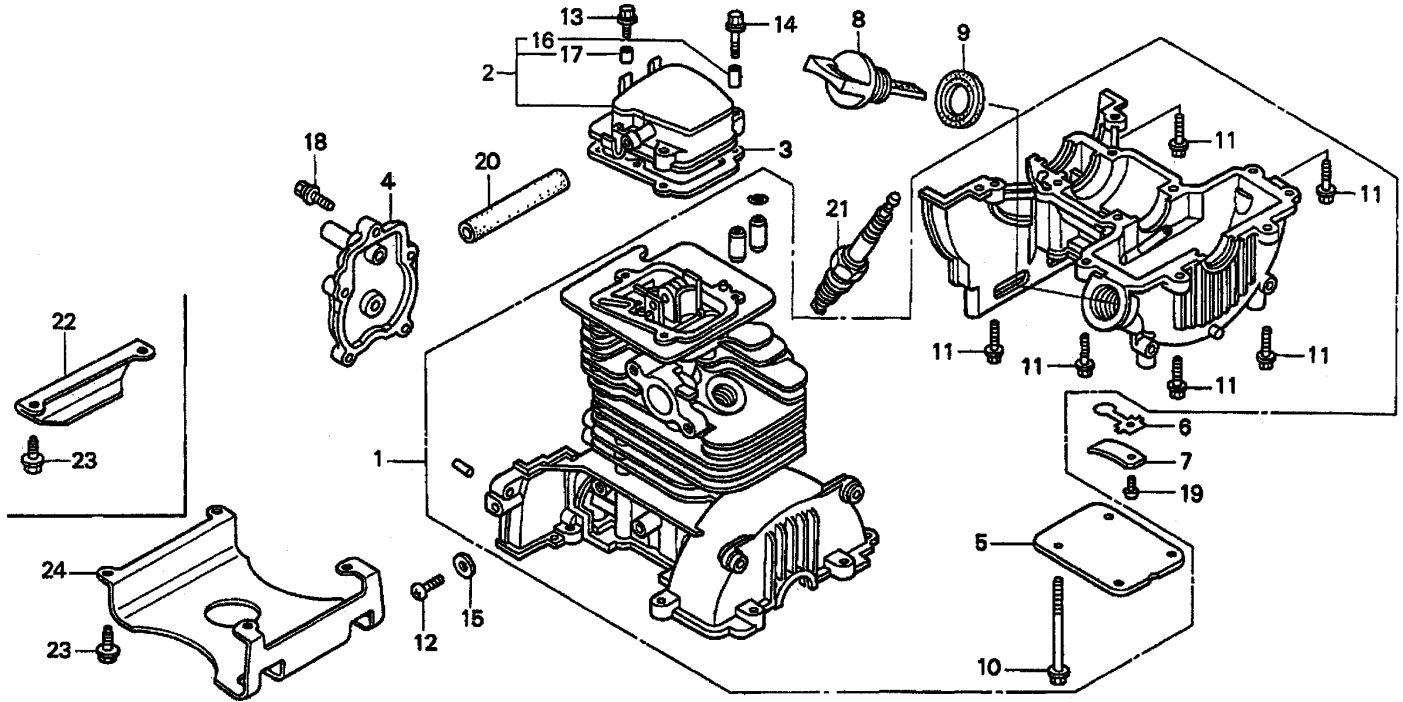

HONDA GX31SA ENGINE — CRANKCASE ASSY.

CRANKCASE ASSY.

<u>NO.</u>	<u>PART NO.</u>	<u>PART NAME</u>	<u>QTY.</u>	<u>REMARKS</u>
1	11010ZM5000	CRANKCASE SET	1	INCLUDES ITEM W/*
1	11010ZM5010	CRANKCASE SET	1	INCLUDES ITEM W/*
2	04102ZM3000	COVER COMP., HEAD	1	INCLUDES ITEM W/# USE UP TO SN1040026
2	12310ZM3000	COVER COMP., HEAD	1	INCLUDES ITEM W/# USE FROM SN1040027
3	12312ZM3000	GASKET, HEAD COVER	1	USE UP TO SN1040026
3	12312ZM3010	GASKET, HEAD COVER	1	USE FROM SN 1040027
4	14121ZM5000	COVER, CAMSHAFT	1	
5*	15511ZM3000	COVER, OIL OUTLET VALVE	1	
6	15571ZM3003	VALVE, OIL OUTLET	1	
7	15572ZM3000	PLATE, STOPPER	1	
8	15620ZM3003	CAP, OIL FILTER	1	
9	15625ZE1003	GASKET, OIL FILTER CAP	1	
10*	90003ZM3000	BOLT, FLANGE (5X55)	4	
11*	90005ZM3000	BOLT, FLANGE (5X18)	6	
12	90011ZM3000	SCREW, PAN (6X8)	1	
13	90002ZM3000	BOLT, FLANGE (5X14)	1	USE FROM SN 1040026
13	90101P4V000	BOLT, FLANGE (5X12)	1	USE UP TO SN 1040027
14	90001ZM3000	BOLT, FLANGE (5X22)	2	USE FROM SN 1040026
14	90112GK8010	BOLT, FLANGE (5X22)	2	USE UP TO SN 1040027
15	90481GW3000	WASHER, SEALING (6.5MM)	1	
16#	91501ZM3000	COLLAR, HEAD COVER	2	USE UP TO SN 1040026
16#	91501ZM3010	COLLAR, HEAD COVER	2	USE FROM SN1040027
17#	91502ZM3000	COLLAR, HEAD COVER	1	USE UP TO SN1040026
17#	91506ZM3000	COLLAR, HEAD COVER	1	USE FROM SN 1040027
18	934010401600	BOLT-WASHER (4X16)	5	
19	93500030050A	SCREW, PAN (3X5)	1	
20	95005700033M	BULK HOSE, VACUUM(7X3000) (7X68)	1	
21	9805655757	SPARK PLUG (U16FSR-UB)	1	
21	9805655777	SPARK PLUG (R5HSB)	1	

HONDA GX31SA ENGINE — CAMSHAFT ASSY.

CAMSHAFT ASSY.

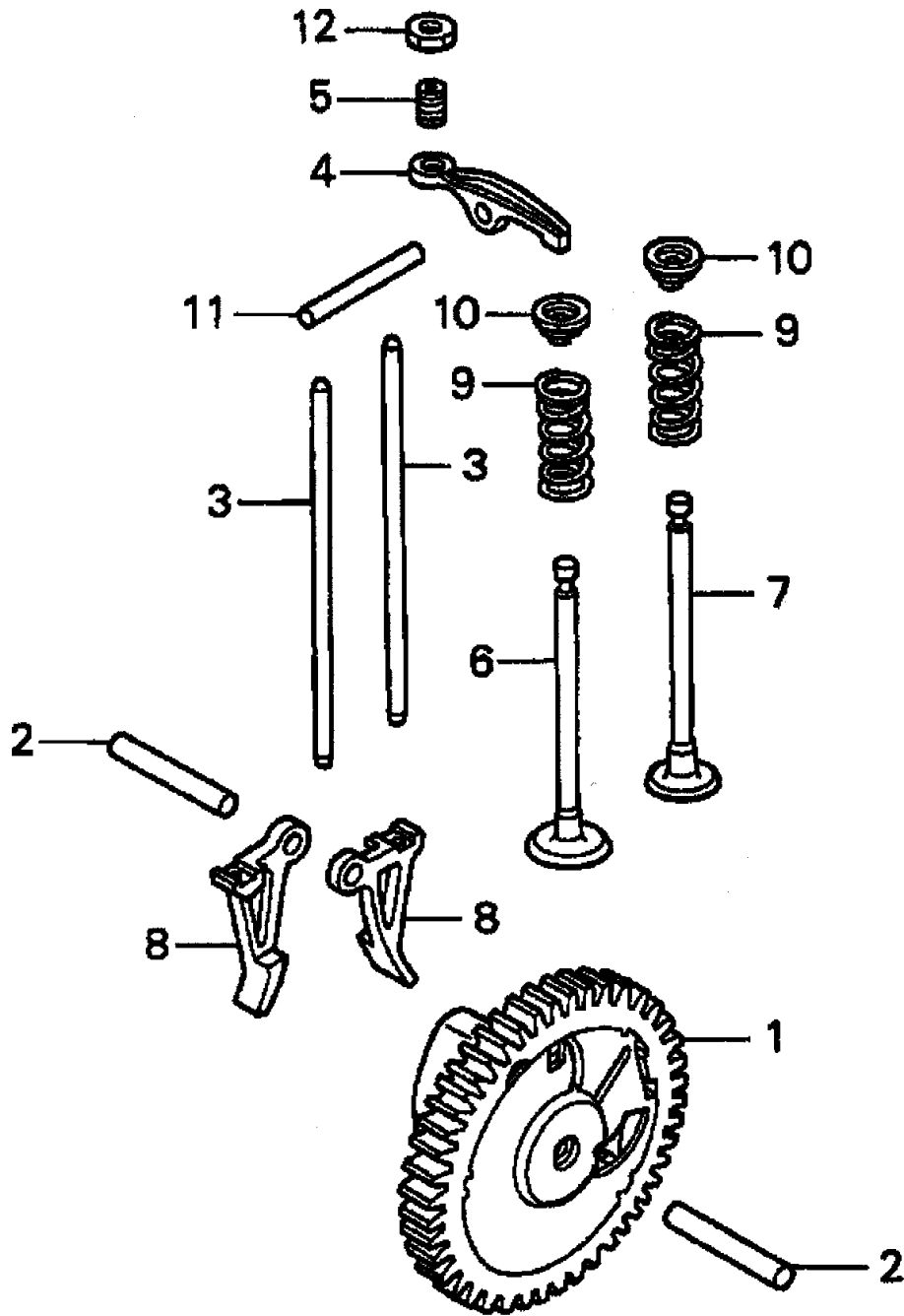

HONDA GX31SA ENGINE — CAMSHAFT ASSY.

CAMSHAFT ASSY.

<u>NO.</u>	<u>PART NO.</u>	<u>PART NAME</u>	<u>QTY.</u>	<u>REMARKS</u>
1	14100ZM3000	CAMSHAFT ASSY.	1	
2	14126ZM3000	ROLLER (5X23.8)	2	
3	14410ZM3000	ROD, PUSH	2	
4	14431ZM3000	ARM, VALVE ROCKER	2	
5	14451ZM3000	PIVOT, ROCKER ARM	2	
6	14711ZM5000	VALVE, IN.	1	
7	14721ZM3000	VALVE, EX.	1	
8	14731ZM3003	LIFTER, VALVE	2	
9	14751ZM3000	SPRING, VALVE	2	
10	14771ZM3000	RETAINER, VALVE SPRING	2	
11	41313PL3000	ROLLER (4X28)	1	
12	90206ZM3000	NUT, TAPPET ADJUSTING	2	

HONDA GX31SA ENGINE — PISTON/CRANKSHAFT ASSY.

PISTON CRANKSHAFT ASSY.

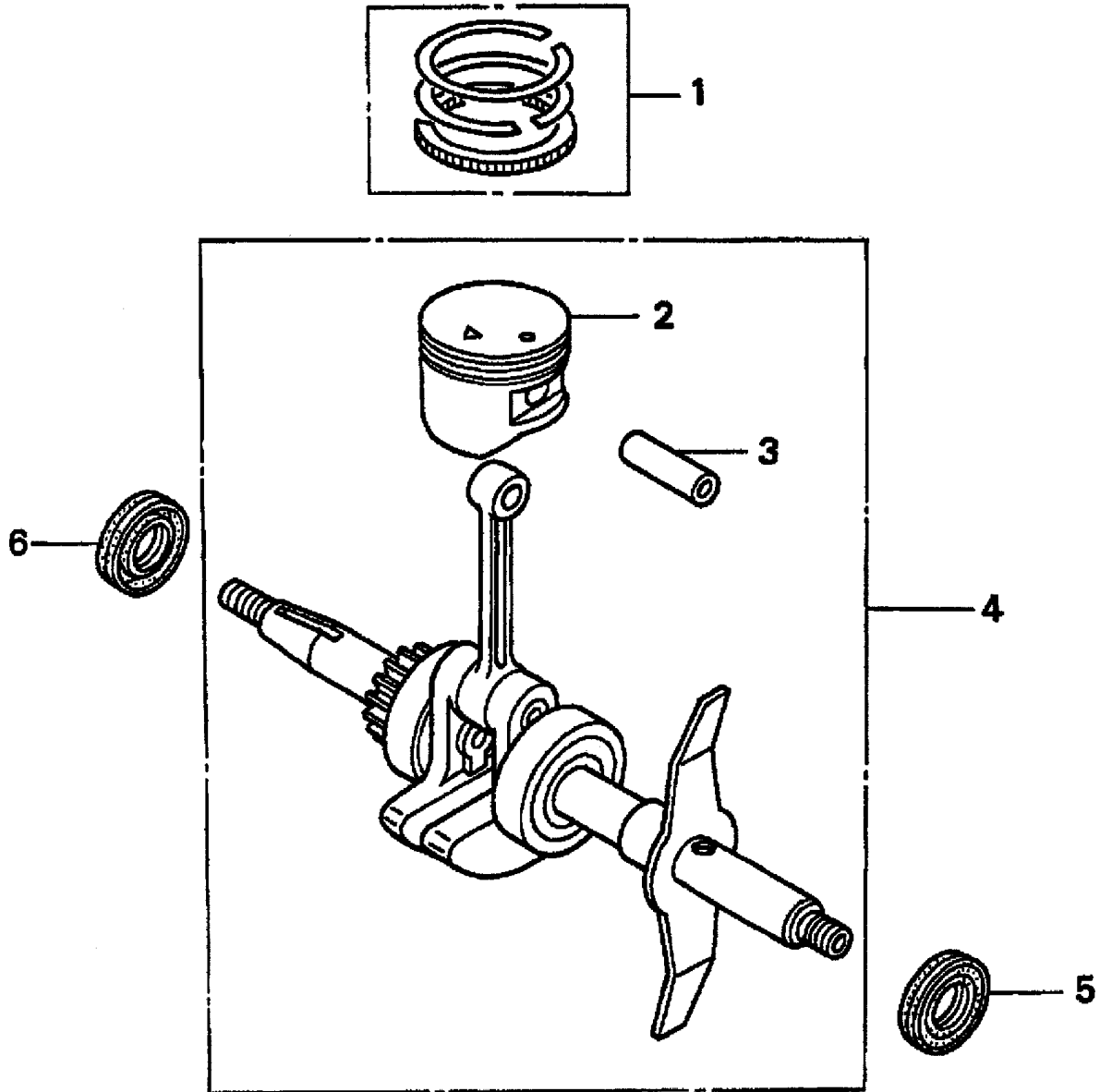

HONDA GX31SA ENGINE — PISTON/CRANKSHAFT ASSY.

PISTON CRANKSHAFT ASSY.

<u>NO.</u>	<u>PART NO.</u>	<u>PART NAME</u>	<u>QTY.</u>	<u>REMARKS</u>
1	13010ZM5000	RING SET, PISTON	1	
2*	13101ZM5000	PISTON	1	
3*	13111ZM5000	PIN, PISTON	1	
4	13310ZM5000	CRANKSHAFT COMP.	1	INCLUDES ITEM W/* USE UP TO SN 1040026
4	13310ZM5020	CRANKSHAFT COMP.	1	INCLUDES ITEM W/* USE FROM SN 1040027
5	91213ZM3003	OIL SEAL (12X25X6)	1	
6	91213ZM3003	OIL SEAL (12X25X6)	1	USE UP TO SN 1040026
6	91214ZM3003	OIL SEAL (15X25X6)	1	USE FROM SN 1040027

HONDA GX31SA ENGINE — CARBURETOR ASSY.

CARBURETOR ASSY.

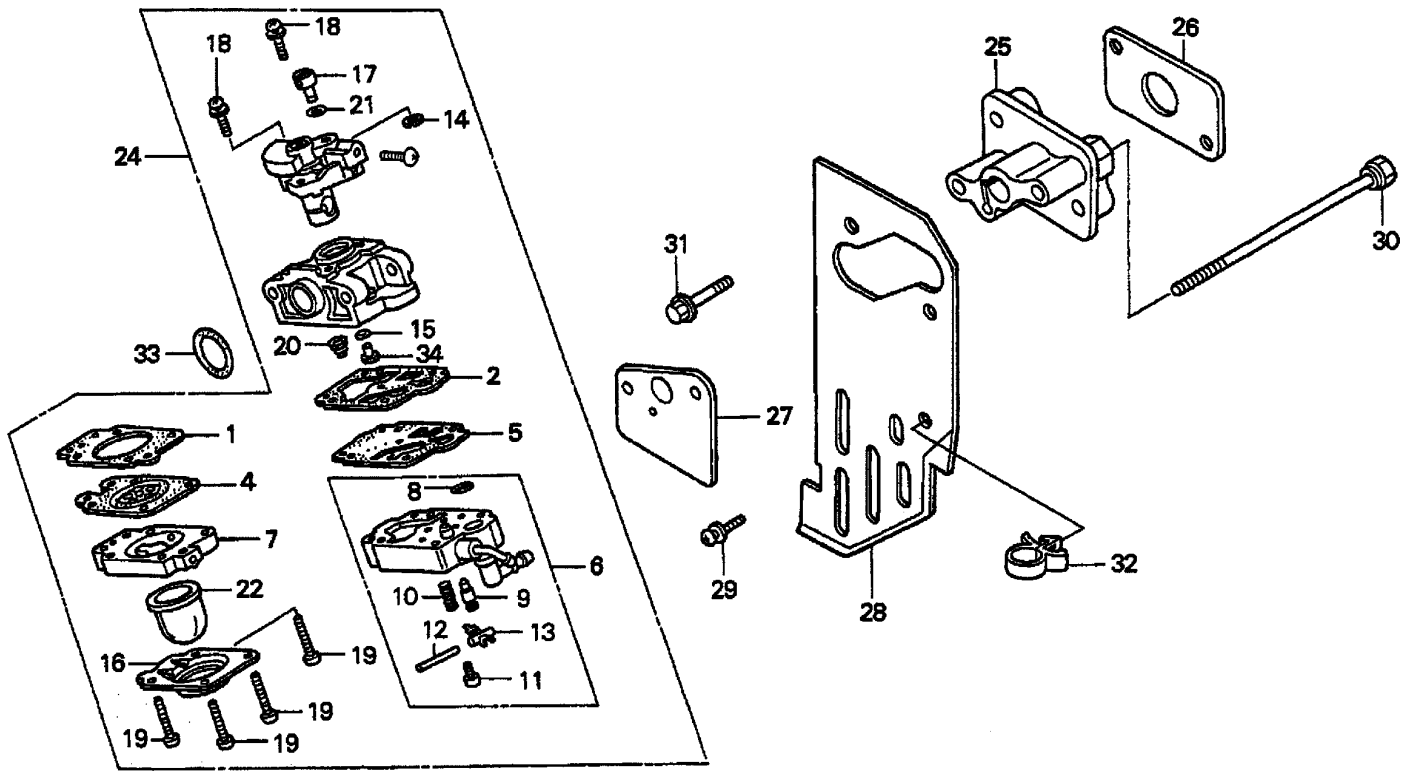

HONDA GX31SA ENGINE — CARBURETOR ASSY.

CARBURETOR ASSY.

<u>NO.</u>	<u>PART NO.</u>	<u>PART NAME</u>	<u>QTY.</u>	<u>REMARKS</u>
1*	16010ZM3004	GASKET, METERING DIAPHRAGM	1	
2*	16011ZM3014	GASKET, PUMP	1	
4*	16013ZM3004	DIAPHRAGM ASSY., METERING	1	
5*	16014ZM3004	DIAPHRAGM, PUMP	1	
6*	16015ZM3004	BODY ASSY., PUMP	1 NCLUDES ITEMS W/#
7*	16017ZM3004	BODY ASSY., AIR PURGE	1	
8#*	16018ZM3004	SCREEN, INLET	1	
9#*	16019ZM3004	VALVE, IN. NEEDLE	1	
10#*	16020ZM3004	SPRING, METERING LEVER	1	
11#*	16021ZM3004	SCREW, METERING LEVER PIN	1	
12#*	16022ZM3004	PIN, METERING LEVER	1	
13#*	16023ZM3004	LEVER, METERING	1	
14*	16024ZM3004	RING, SPRING RETAINING	1	
15*	16025ZM3004	O-RING	1	
16*	16026ZM3004	COVER, PRIMER PUMP	1	
17*	16027ZM3004	SWIVEL	1	
18*	16028ZM3004	SCREW, THROTTLE COLLAR	2	
19*	16029ZM3004	SCREW, PUMP COVER	4	
20*	16030ZM3004	SPRING, PUMP	1	
21*	16031ZM3004	WASHER	1	
22*	16032ZM3004	PUMP, PRIMER	1	
24	16100ZM5804	CARBURETOR ASSY.	1 INCLUDES ITEMS W/*
25	16211ZM3000	INSULATOR, CARBURETOR	1	
26	16212ZM3000	GASKET, INSULATOR	1	
27	16221ZM3000	GASKET, CARBURETOR	1	
28	19651ZM3000	GUIDE, AIR IN.	1	
29	938940501000	SCREW-WASHER (5X10)	1	
30	90010ZM3000	BOLT, HEX. (5X75)	2	
31	90112GK8010	BOLT, FLANGE (5X22)	2	
32	90659680013	CLIP, WIRE HARNESS	1	
33	91301ZM3000	O-RING (14.8X2.4)	1	
34*	99101ZM30380	JET (#38) (OPTIONAL)	1	
34*	99101ZM30390	JET (#39) (OPTIONAL)	1	
34*	99101ZM30400	JET (#40)	1	

HONDA GX31SA ENGINE — RECOIL STARTER ASSY.

RECOIL STARTER ASSY.

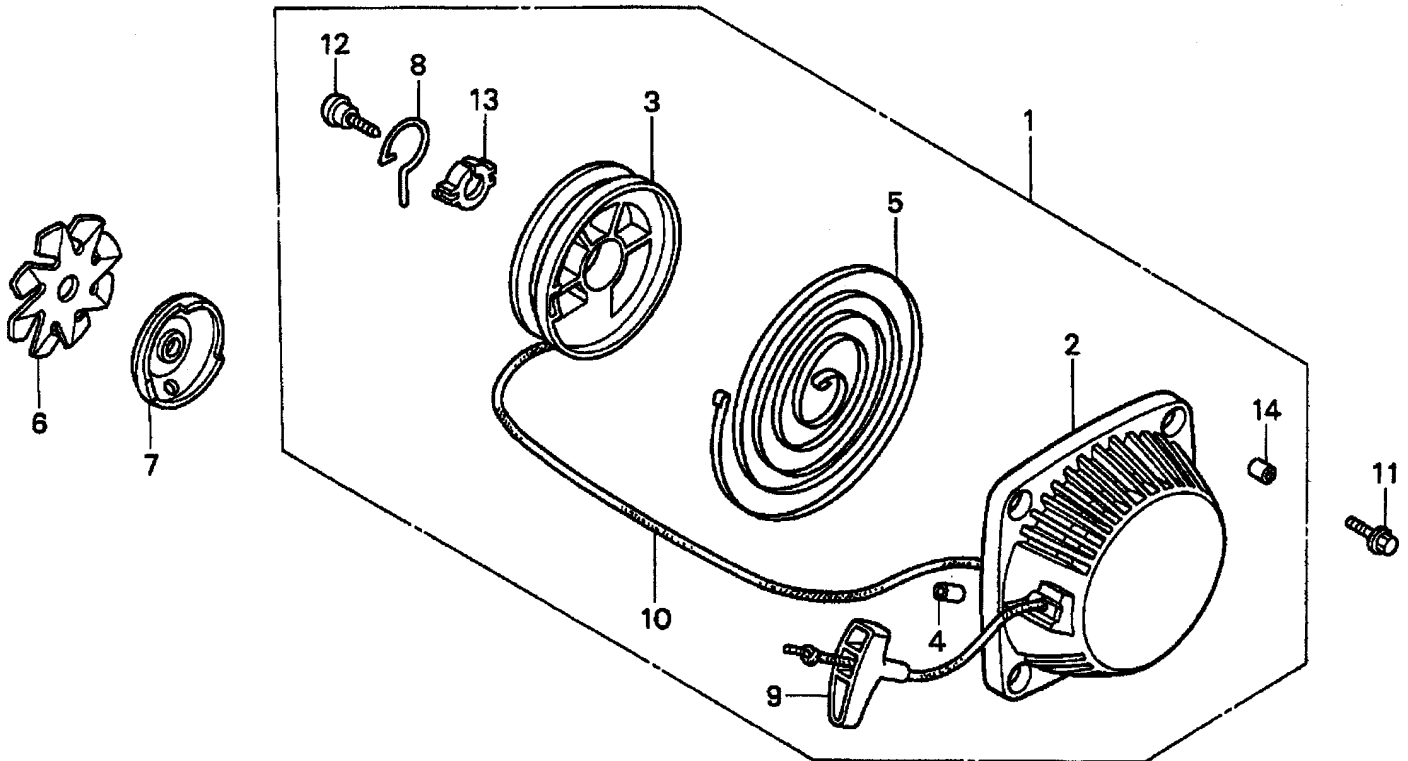

HONDA GX31SA ENGINE — RECOIL STARTER ASSY.

RECOIL STARTER ASSY.

<u>NO.</u>	<u>PART NO.</u>	<u>PART NAME</u>	<u>QTY.</u>	<u>REMARKS</u>
1	28400ZM3003ZA	RECOIL STARTER ASSY.	1	INCLUDES ITEMS W/*
2*	28414ZM3003	CASE, RECOIL STARTER	1	
3*	28421ZM3003	REEL, RECOIL STARTER	1	
4*	28433ZM3003	GUIDE, ROPE	1	
5*	28442ZM3003	SPRING, RECOIL STARTER	1	
6	28447ZM3000	FAN, RACHET	1	
7	28451ZM3003	PULLEY, RECOIL STARTER	1	
8*	28459ZM3003	SWING ARM	1	
9*	28461ZM3003	KNOB, RECOIL STARTER	1	
10*	28462ZM3003	ROPE, RECOIL STARTER	1	
11	90005ZM3000	BOLT, FLANGE (5X18)	4	
12*	90012ZM3003	SCREW, SETTING	1	
13*	91504ZM3003	COLLAR	1	
14*	91505ZM3003	COLLAR	4	

HONDA GX31SA ENGINE — FLYWHEEL/IGNITION COIL ASSY.

FLYWHEEL/IGNITION COIL ASSY.

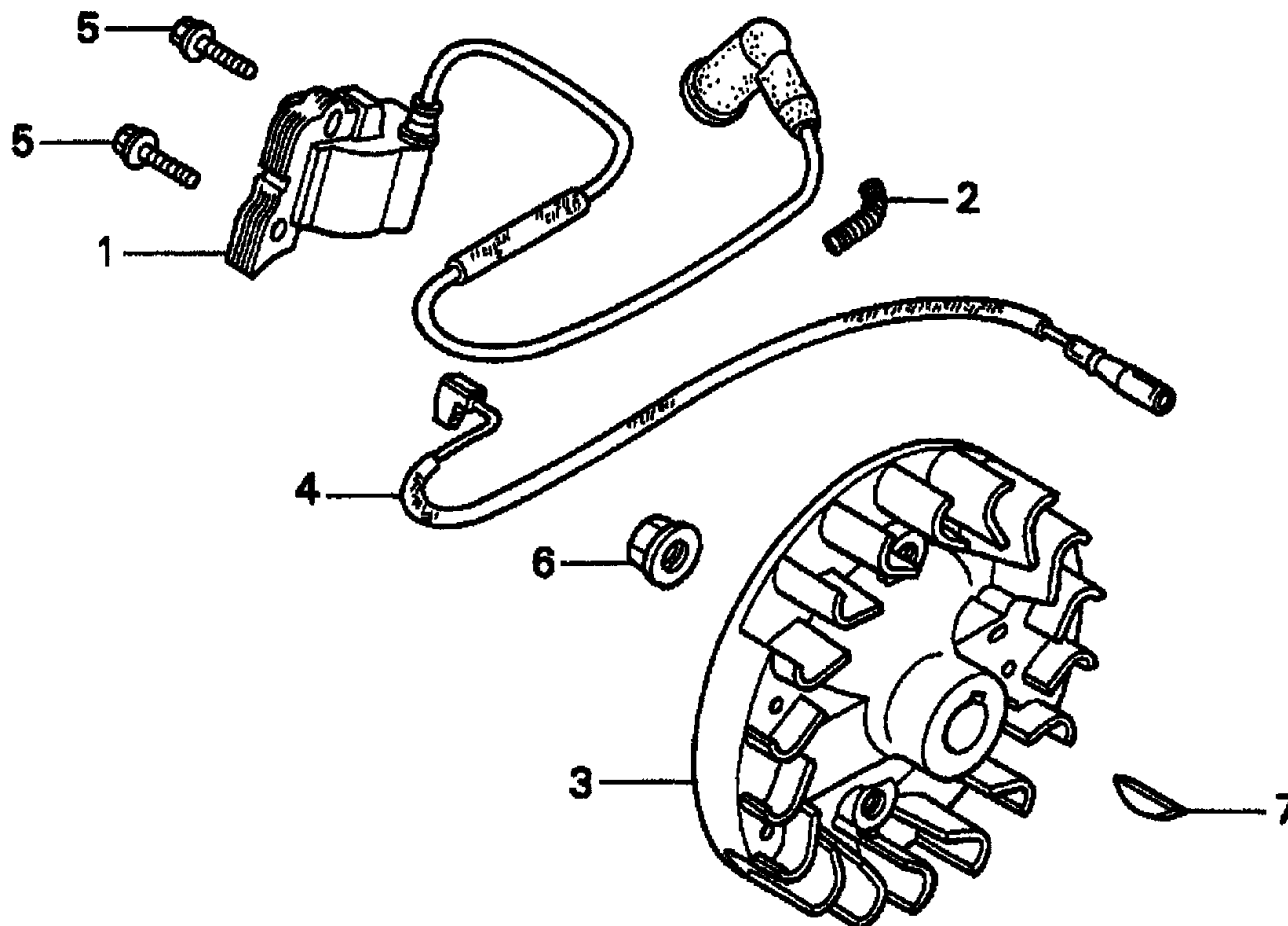

HONDA GX31SA ENGINE — FLYWHEEL/IGNITION COIL ASSY.

FLYWHEEL/IGNITION COIL ASSY.

<u>NO.</u>	<u>PART NO.</u>	<u>PART NAME</u>	<u>QTY.</u>	<u>REMARKS</u>
1	30500ZM3003	COIL ASSY., IGNITION	1	
2	30519ZM3000	TUBE A, CORRUGATED (7X18)	1	
3	31110ZM5003	FLYWHEEL COMP.	1 USE UP TO SN 1040026
3	31110ZM5013	FLYWHEEL COMP.	1 USE FROM SN 1040027
4	32195ZM3000	WIRE, STOP SWITCH	1	
5	934010501600	BOLT-WASHER (5X16)	2	
6	9405008000	NUT, FLANGE (8MM)	1 USE UP TO SN 1040026
6	9405010000	NUT, FLANGE (10MM)	1 USE FROM SN 1040027
7	9440116120	KEY, WOODRUFF (16X12)	1	

HONDA GX31SA ENGINE — FUEL TANK ASSY.

FUEL TANK ASSY.

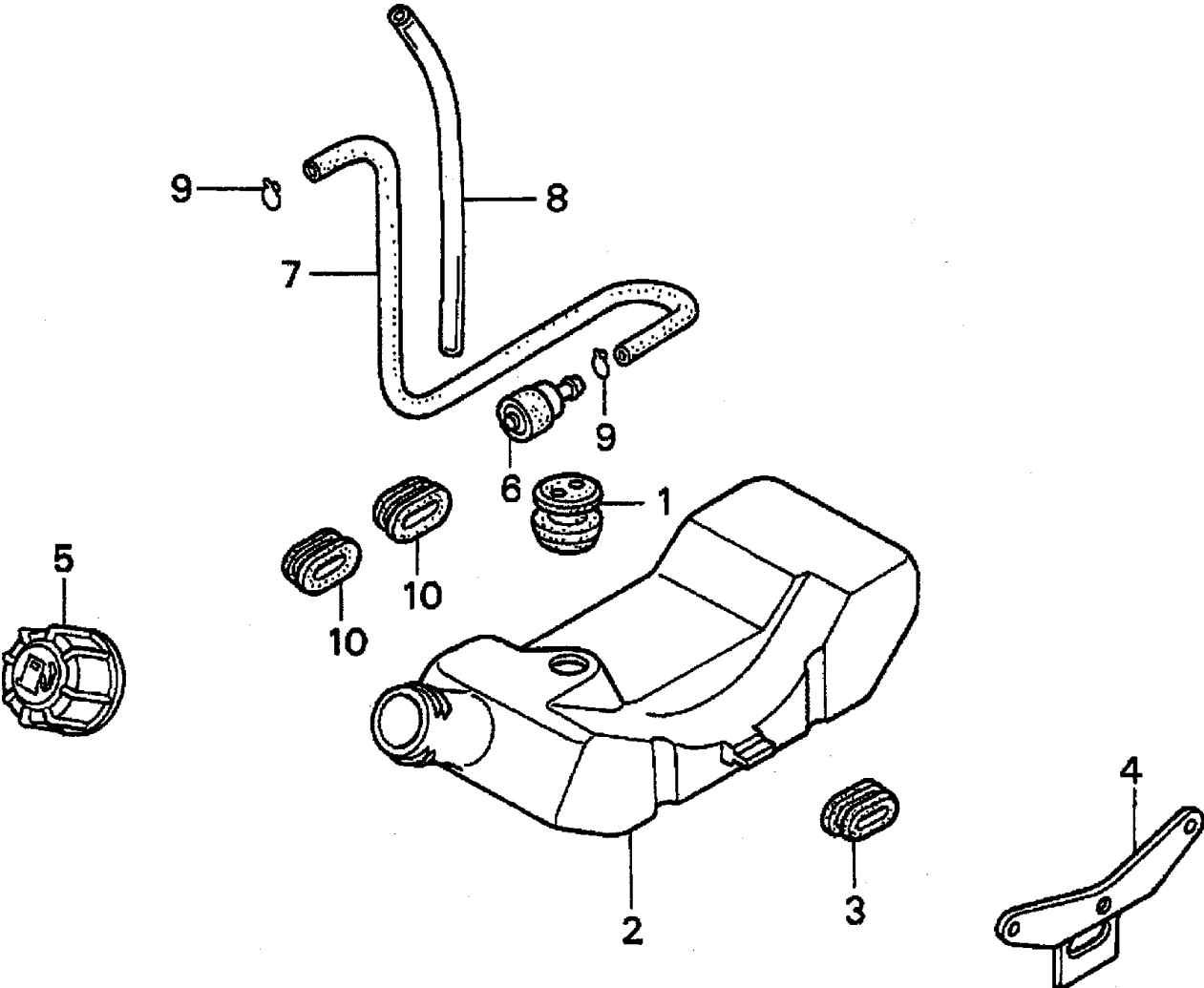

HONDA GX31SA ENGINE — FUEL TANK ASSY.

FUEL TANK ASSY.

<u>NO.</u>	<u>PART NO.</u>	<u>PART NAME</u>	<u>QTY.</u>	<u>REMARKS</u>
1	17504ZM3003	GROMMET, FUEL TUBE	1	
2	17511ZM5003	TANK, FUEL	1	
3	17532ZM3000	RUBBER, TANK MOUNTING	1	USE UP TO SN 1040026
3	17532ZM3010	RUBBER A, TANK MOUNTING	1	USE FROM SN 1040027
3	17533ZM3000	RUBBER B, TANK MOUNTING	1	USE UP TO SN 1040026
4	17561ZM3000	STAY, FUEL TANK	1	USE UP TO SN 1040026
4	17561ZM3010	STAY, FUEL TANK	1	USE FROM SN 1040027
5	17620ZM3023	CAP ASSY., FUEL TANK	1	USE UP TO SN 1064797
5	17620ZM3033	CAP ASSY., FUEL TANK	1	USE FROM SN 1040027
6	17672ZM3003	FILTER, FUEL	1	
7	17701ZM3003	TUBE, FUEL	1	
8	17702ZM3003	TUBE, FUEL RETURN	1	
9	91401ZM3003	CLIP, TUBE	2	
10	17532ZM3000	RUBBER, TANK MOUNTING	2	USE UP TO SN 1040026
10	17533ZM3000	RUBBER B, TANK MOUNTING	2	USE UP TO SN 1040027

HONDA GX31SA ENGINE — AIR CLEANER ASSY.

AIR CLEANER ASSY.

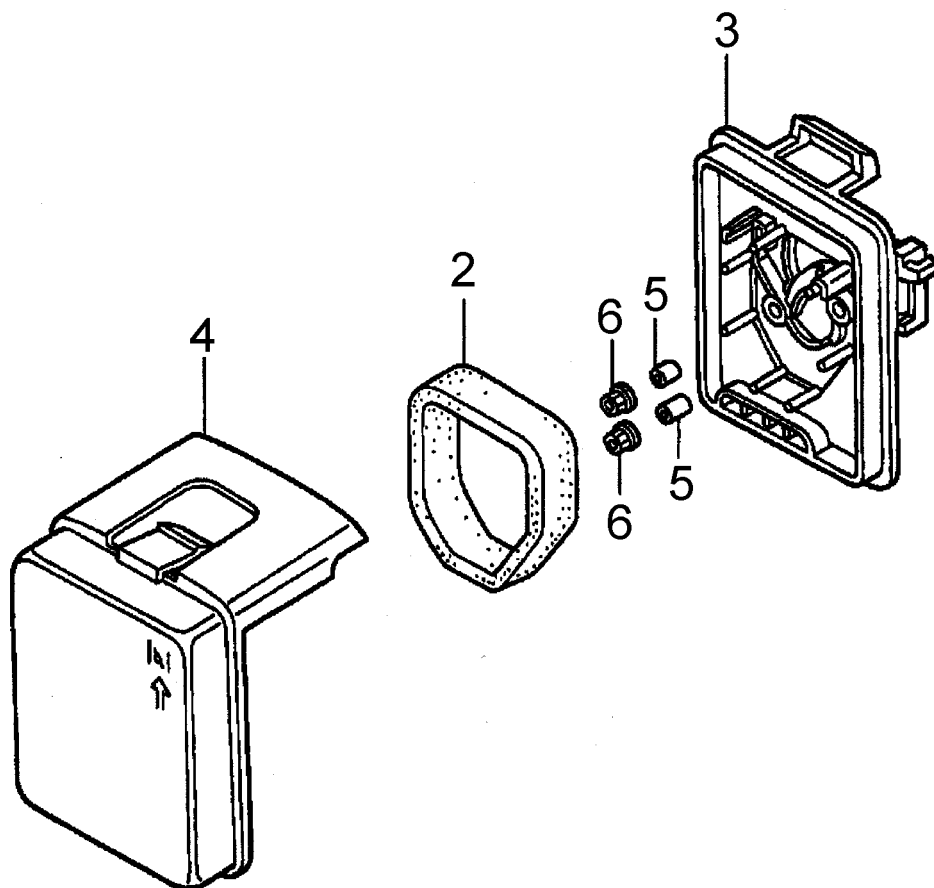

HONDA GX31SA ENGINE — AIR CLEANER ASSY.

AIR CLEANER ASSY.

<u>NO.</u>	<u>PART NO.</u>	<u>PART NAME</u>	<u>QTY.</u>	<u>REMARKS</u>
2	17211ZM3000	ELEMENT, AIR CLEANER	1	
3	17220ZM3000ZA	HOUSING COMP., AIR CLEANER	1	BRIGHT RED
4	17231ZM3000ZA	COVER, AIR CLEANER	1	BRIGHT RED
5	91503ZM3000	COLLAR, AIR CLEANER	2	
6	9405005000	NUT, FLANGE (5MM)	2	

HONDA GX31SA ENGINE — MUFFLER ASSY.

MUFFLER ASSY.

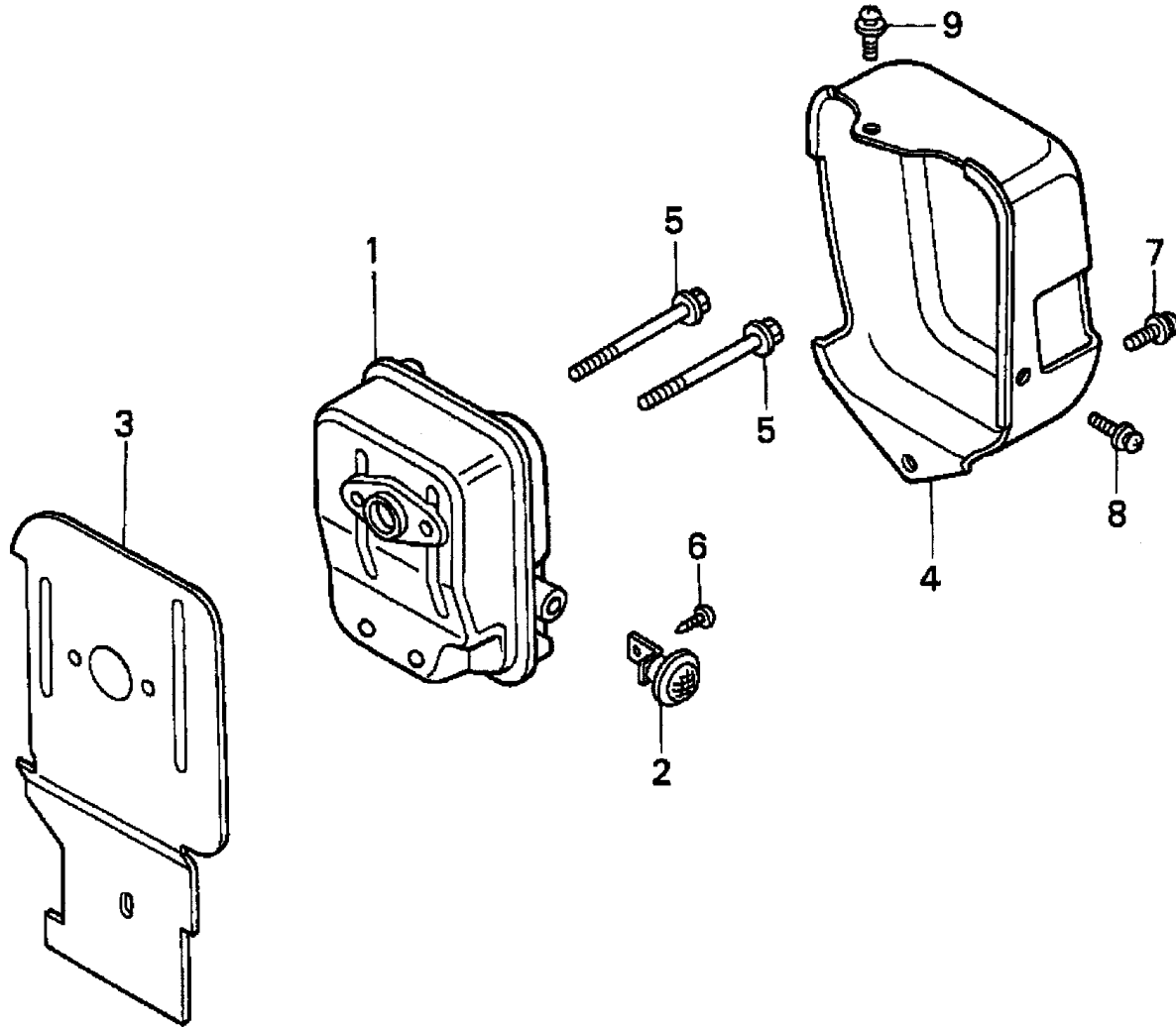

HONDA GX31SA ENGINE — MUFFLER ASSY.

MUFFLER ASSY.

<u>NO.</u>	<u>PART NO.</u>	<u>PART NAME</u>	<u>QTY.</u>	<u>REMARKS</u>
1	18310ZM3800	MUFFLER COMP.	1	
2	18355ZM3801	ARRESTER ,SPARK	1	
3	18515ZM3000	GUIDE, AIR EX.	1	
4	19722ZM3000	INNER COVER, TOP	1	USE UP TO SN 1007272
4	19722ZM3810	INNER COVER, TOP	1	USE FROM SN 1007273
5	90004ZM3000	BOLT, FLANGE (5X50)	2	
6	90055ZE1000	SCREW, TAPPING (4X6)	1	
7	938910500800	SCREW - WASHER (5X8)	1	
8	938940501000	SCREW - WASHER (5X10)	1	
9	938940501600	SCREW - WASHER (5X16)	1	

HONDA GX31SA ENGINE — CLUTCH/FAN COVER ASSY.

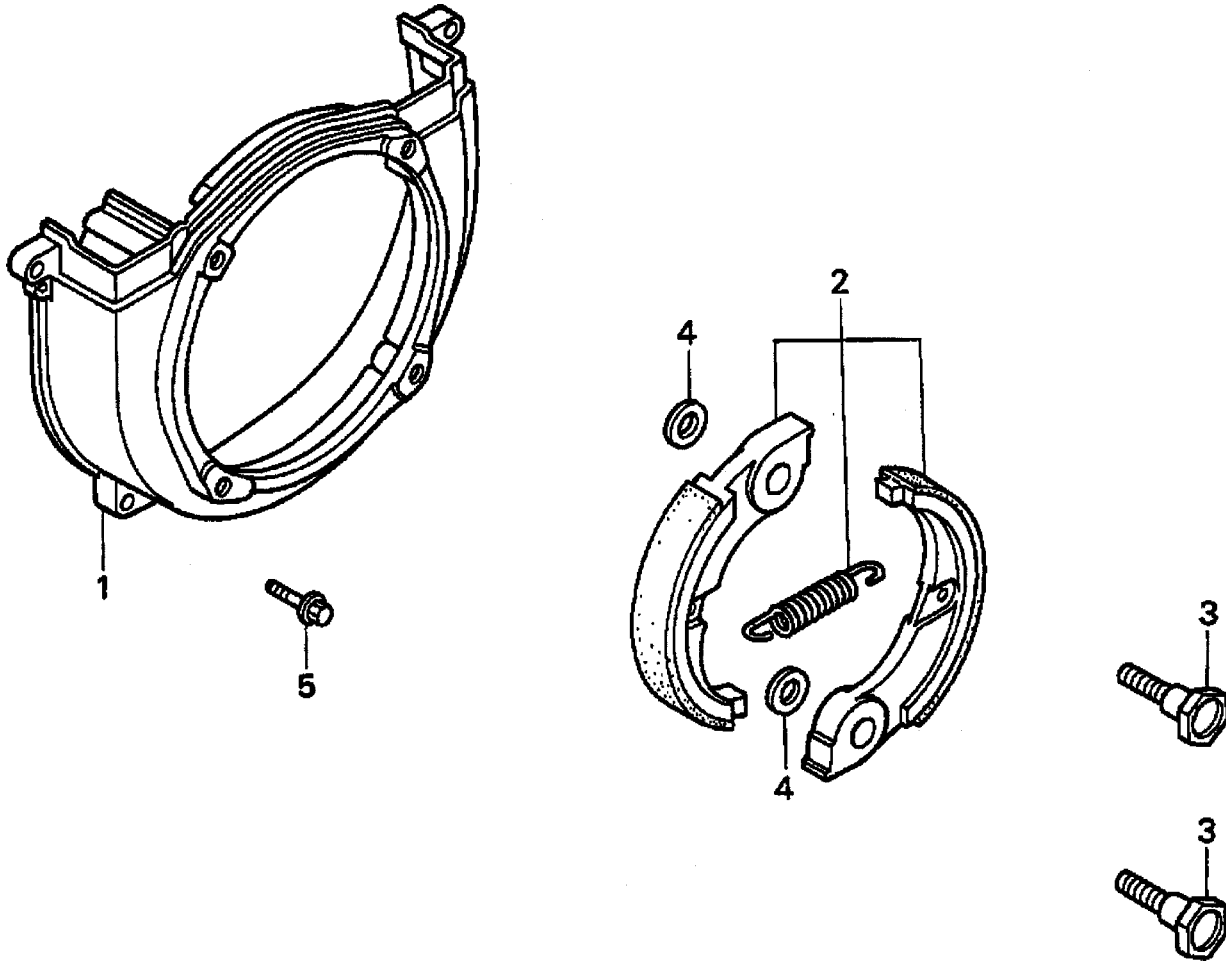

HONDA GX31SA ENGINE — CLUTCH/FAN COVER ASSY.

CLUTCH/FAN COVER ASSY.

<u>NO.</u>	<u>PART NO.</u>	<u>PART NAME</u>	<u>QTY.</u>	<u>REMARKS</u>
1	19611ZM5000	COVER, FAN	1	
2	22000ZM5003	CLUTCH ASSY.	1	
3	22253ZM5003	BOLT, CLUTCH (8MM)	2	
4	22254ZM5003	WASHER, CLUTCH (8X17)	2	
5	90005ZM3000	BOLT, FLANGE (5X18)	2	

HONDA GX31SA ENGINE — ENGINE COVER ASSY.

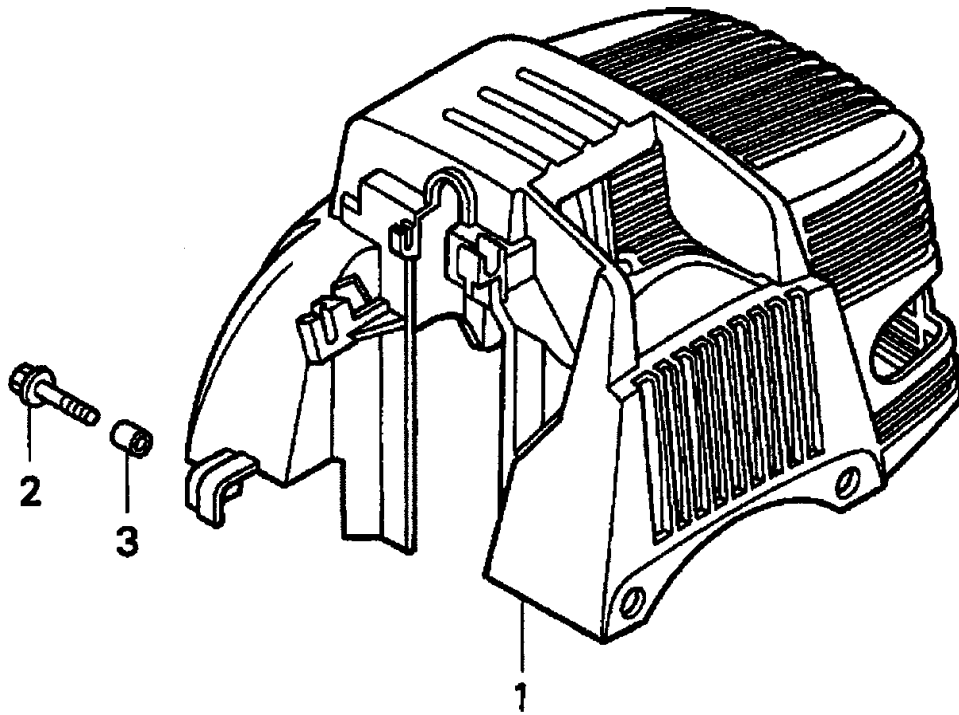

HONDA GX31SA ENGINE — ENGINE COVER ASSY.

ENGINE COVER ASSY.

<u>NO.</u>	<u>PART NO.</u>	<u>PART NAME</u>	<u>QTY.</u>	<u>REMARKS</u>
1	19720ZM3000ZA	COVER COMP., TOP *R8*	1	BRIGHT RED
2	90112GK8010	BOLT, FLANGE (5X22)	2	
3	91502ZM3000	COLLAR, TOP COVER	2	

PAYMENT TERMS

Terms of payment for parts are net 10 days.

FREIGHT POLICY

All parts orders will be shipped collect or prepaid with the charges added to the invoice. All shipments are F.O.B. point of origin. Multiquip's responsibility ceases when a signed manifest has been obtained from the carrier, and any claim for shortage or damage must be settled between the consignee and the carrier.

MINIMUM ORDER

The minimum charge for orders from Multiquip is \$15.00 net. Customers will be asked for instructions regarding handling of orders not meeting this requirement.

RETURNED GOODS POLICY

Return shipments will be accepted and credit will be allowed, subject to the following provisions:

1. A Returned Material Authorization must be approved by Multiquip prior to shipment.
2. To obtain a Return Material Authorization, a list must be provided to Multiquip Parts Sales that defines item numbers, quantities, and descriptions of the items to be returned.
 - a. The parts numbers and descriptions must match the current parts price list.
 - b. The list must be typed or computer generated.
 - c. The list must state the reason(s) for the return.
 - d. The list must reference the sales order(s) or invoice(s) under which the items were originally purchased.
 - e. The list must include the name and phone number of the person requesting the RMA.
3. A copy of the Return Material Authorization must accompany the return shipment.

4. Freight is at the sender's expense. All parts must be returned freight prepaid to Multiquip's designated receiving point.
5. Parts must be in new and resalable condition, in the original Multiquip package (if any), and with Multiquip part numbers clearly marked.
6. The following items are not returnable:
 - a. Obsolete parts. (If an item is listed in the parts price book as being replaced by another item, it is obsolete.)
 - b. Any parts with a limited shelf life (such as gaskets, seals, "O" rings, and other rubber parts) that were purchased more than six months prior to the return date.
 - c. Any line item with an extended dealer net price of less than \$5.00.
 - d. Special order items.
 - e. Electrical components.
 - f. Paint, chemicals, and lubricants.
 - g. Decals and paper products.
 - h. Items purchased in kits.
7. The sender will be notified of any material received that is not acceptable.
8. Such material will be held for 5 working days from notification, pending instructions. If a reply is not received within 5 days, the material will be returned to the sender at his expense.
9. Credit on returned parts will be issued at dealer net price at time of the original purchase, less a 15% restocking charge.
10. In cases where an item is accepted for which the original purchase document can not be determined, the price will be based on the list price that was effective twelve months prior to the RMA date.
11. Credit issued will be applied to future purchases only.

PRICING AND REBATES

Prices are subject to change without prior notice. Price changes are effective on a specific date and all orders received on or after that date will be billed at the revised price. Rebates for price declines and added charges for price increases will not be made for stock on hand at the time of any price change.

Multiquip reserves the right to quote and sell direct to Government agencies, and to Original Equipment Manufacturer accounts who use our products as integral parts of their own products.

SPECIAL EXPEDITING SERVICE

A \$20.00 to \$50.00 surcharge will be added to the invoice for special handling including bus shipments, insured parcel post or in cases where Multiquip must personally deliver the parts to the carrier.

LIMITATIONS OF SELLER'S LIABILITY

Multiquip shall not be liable here under for damages in excess of the purchase price of the item with respect to which damages are claimed, and in no event shall Multiquip be liable for loss of profit or good will or for any other special, consequential or incidental damages.

LIMITATION OF WARRANTIES

No warranties, express or implied, are made in connection with the sale of parts or trade accessories nor as to any engine not manufactured by Multiquip. Such warranties made in connection with the sale of new, complete units are made exclusively by a statement of warranty packaged with such units, and Multiquip neither assumes nor authorizes any person to assume for it any other obligation or liability whatever in connection with the sale of its products. A part from such written statement of warranty, there are no warranties, express, implied or statutory, which extend beyond the description of the products on the face hereof.

PARTS AND OPERATION MANUAL

HERE'S HOW TO GET HELP

*PLEASE HAVE THE MODEL AND SERIAL NUMBER
ON-HAND WHEN CALLING*

PARTS DEPARTMENT

800-427-1244 or 310-537-3700

FAX: 800-672-7877 or 310-637-3284

SERVICE DEPARTMENT/TECHNICAL ASSISTANCE

800-478-1244 or 310-537-3700

FAX: 310- 537-4259

WARRANTY DEPARTMENT

888-661-4279, or 310-661-4279

FAX: 310- 537-1173

MAIN

800-421-1244 or 310-537-3700

FAX: 310-537-3927

Manufactured For Multiquip Inc.
by
LIEVERS, HOLLAND
Bovenkamp 3, 1391 LA Abcoude
P.O. Box 43, 1390 AA Abcoude



MULTIQUIP INC.
18910 WILMINGTON AVE.
CARSON, CALIFORNIA 90746
310-537-3700
800-421-1244
FAX: 310-537-3927
E-mail: mq@multiquip.com

PARTS DEPARTMENT:

800-427-1244
FAX: 800-672-7877

SERVICE DEPARTMENT:

800-478-1244
FAX: 310-537-4259

• www.multiquip.com