

FAMILIARIZING YOURSELF WITH THE CONTROLS

On the right side of the machine are the following switches and controls. (Figure 1)

Main Power ⚡

“0” Position: Off position. Power is turned off to all functions.

“I” Position: On position. Machine has power.

Display light 💡

“0” Position: Lights are off.

“I” Position: Lights are on. Display lights have power

Agitator Switch ↻

“0” Position: Agitator is off.

“I” Position: Agitator is on.

Cooler Switch ❄️ / 🍹

“0” Position: Off position.

“I” Position: Cool drink mode. 🍹

“II” Position: Frozen mode. ❄️

Compressor green light 🟢

If the compressor green light is on, the compressor should be working

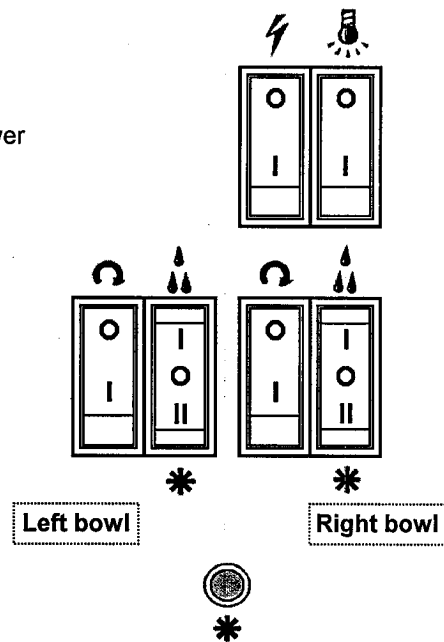

Figure 1

Automatic defrost / standby timer (Figure 2)

This timer will automatically switch your dispenser from the frozen drink to the chilled drink mode. This timer can be programmed to switch the machine at any time of the day or night. The standard settings are:
 Switch to chilled from frozen – 11:00 PM
 Switch to frozen from chilled – 9:00 AM
 For all seven days of the week.
 Find detailed programming instructions on page 12.

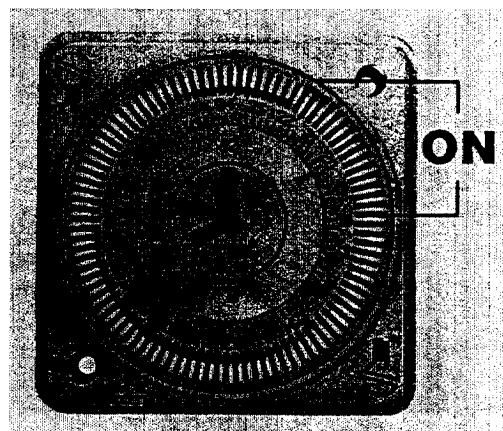

Figure 2

CLEANING & SANITIZING Instructions: Model GB-110-220-330 Dispensers

CLEAN & SANITIZE DISPENSER AT LEAST EVERY THREE DAYS OR AS REQUIRED BY LOCAL REGULATORY AGENCY. SOME PRODUCTS MAY REQUIRE MORE FREQUENT SANITIZING.

WHY MUST THE DISPENSER BE SANITIZED? Once the Syrup is removed from its original container and poured into the Dispenser bowl, it is possible for airborne bacteria and other micro-organisms to enter the product. Over a period of time, this can affect flavor quality and possibly even represent a health hazard. Regular Cleaning and Sanitizing with an approved Sanitizing agent will prevent this. It is extremely important to follow instructions exactly.

PREPARATIONS FOR SANITIZING. Tips to minimize product waste and sales interruption:

1. Plan ahead to Sanitize the Dispenser during a *slow time of the day.* Performing the process *before opening for business or after closing* is ideal.
2. Let the product level "run down" from selling just before the Sanitizing time. *This minimal amount of product MUST be discarded for Sanitizing to be effective.*
3. Allow enough time after Sanitizing and re-filling for product to freeze back (about 1 ½ hours).

CLEANING & SANITIZING. Process should be performed on ONE BOWL at a TIME.

PART ONE Disassembly, and Cleaning of Dispenser:



1. Turn OFF all Dispenser Switches



2. Unplug Lid Cord. Remove Lid and set it aside (Do not immerse it in water). Pour 1 to 2 Gal. Of Ward Water into Bowl to soften remaining product and aid draining. Wstirring with a Plastic Utensil will help melt product.



3. Drain all product and discard.

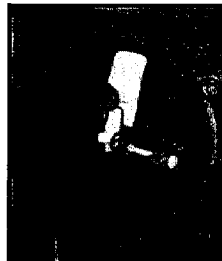

4. Pull Pin from Dispensing Valve. Place in a small plastic container for cleaning with other parts.
NOTE: Spring may come off. It can be replaced later. Refer to other Bowl Valve as reference for replacement.

KEEP ALL DISPENSING VALVE PARTS TOGETHER

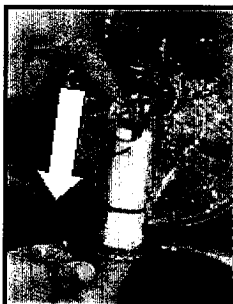

5. Push DOWN on Piston and remove it.

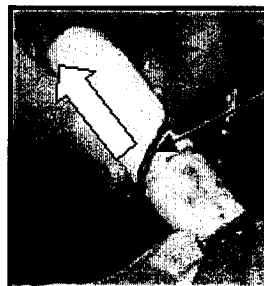

6. Carefully remove both "O"-Rings (there are two) from Piston. Use your fingers to do this. Anything else can tear the "O"-Ring causing leaks. Place the "O"-Rings and Piston in a small plastic container for cleaning with other parts.

CLEANING & SANITIZING Instructions: Model GB-110, 220, 330 Dispensers

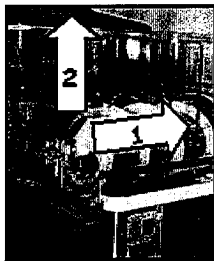

7a Push in / lift up

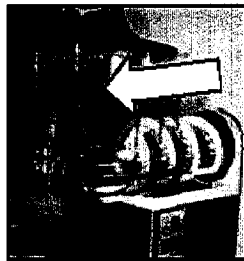

7b Pull off

7 a, b. Remove Bowl. Push bottom of Bowl towards rear of dispenser, and lift UP until the Bowl Natch clears the dispenser base. Pull the Bowl off of the rear Gasket. Move Bowl back and forth slightly while pulling. Place in sink for cleaning with other parts.

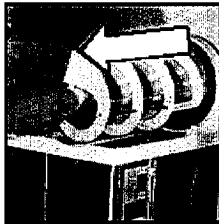

8. Grasp center of Spiral Agitator and pull towards FRONT of dispenser. Remove it and place in sink for cleaning with other parts.

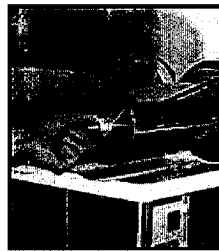

9. Pull off Front Rubber Seal. Place in sink for cleaning with other parts.



10a Pry Gasket off

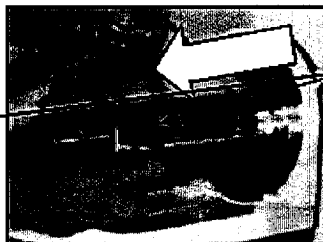

10b Pull Gasket off

10 a, b. Pull off rear Bowl Seal Gasket. Place in sink for cleaning with other parts. Use fingers only. DO NOT pry off with a sharp object....it will tear the Gasket causing leaks.



11. Use a soft cloth or Sponge with warm water and a mild detergent to clean the Stainless Steel Freezing cylinder and area below it.

DO NOT USE THE CYLINDER TO LIFT OR MOVE MACHINE.

12 a, b, c, d. Use a soft Cloth or Sponge with warm water and a mild NON-ABRASIVE detergent to clean these parts. Rinse with warm water.

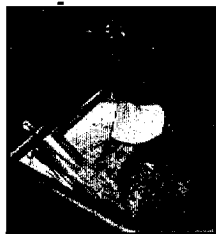

12a Bowl



12b Front Seal

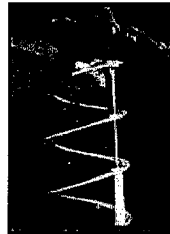

12c Spiral Beater Blade

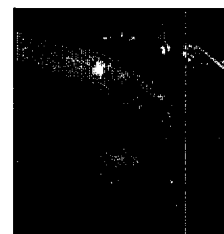

12d Bowl Seal Gasket

CLEANING & SANITIZING Instructions: Model GB-110, 220, 330 Dispensers



13a Piston



13b "O"-Rings

13 a,b. Clean Dispensing Valve Piston and both "O"-Rings with warm water and a mild detergent. After cleaning, install "O"-Rings back onto the Piston. Be sure they are seated in the grooves on the Piston.

14. Remove and clean Drip Trays by lifting UP slightly and pulling OUT. After cleaning, re-install them.

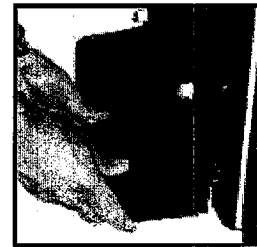

PART TWO Re-assemble Dispenser:

15. Install Bowl Gasket with THICK END TOWARDS THE BACK of Dispenser.

Gasket

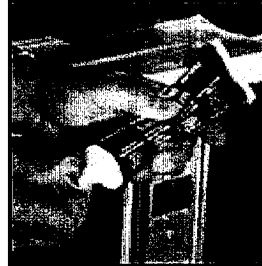

16. Lubricate Rubber Seal. Apply a small amount of approved *food grade lubricant* to the inside, cupped area of the seal. Spread it evenly around the area.

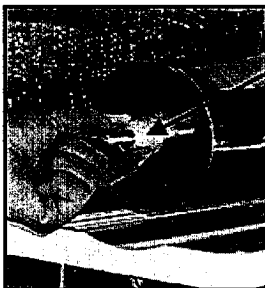

17. Install Rubber Seal onto the Drive Shaft at the front of the Stainless Steel Freezing Cylinder. Make sure the "Cupped" end of the seal is against the front surface of the Cylinder.

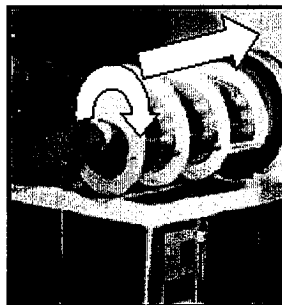

18. Install Spiral Blade over Freezing Cylinder. Make sure the slotted end of the drive shaft is seated in the slot of the Spiral Blade. Turn and push the Blade in to help seat.



19. Apply a small amount of *food grade lubricant* to the end of the Spiral Blade. Spread it evenly over the end.

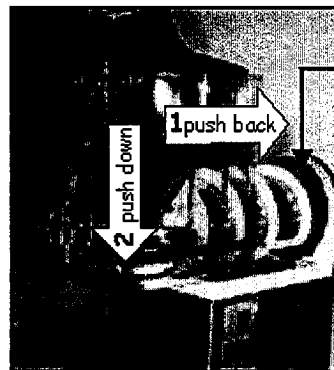

20. Install Bowl. Wet the Bowl Gasket with water and "twist" bowl back and forth while pushing it over the Gasket. Make sure the front end of the Spiral Blade seats in to the metal ring on the inside front of Bowl. Ensure the *Bowl Notch at bottom of Bowl is pushed down onto the Dispenser Base.*

CLEANING & SANITIZING Instructions: Model GB-110, 220, 330 Dispensers

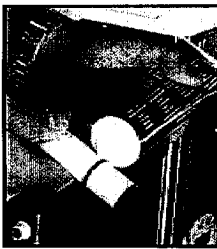

21. Lubricate Dispensing Valve Piston by applying a small amount of *food grade lubricant* on to each "O"-Ring. Spread lubricant evenly around the "O"-Rings.



22. Insert Piston up into clear plastic housing. Make sure slot in Piston is facing to the front.



23. Install Dispensing Valve Handle by inserting the bottom end into the Piston Slot. Push Handle (with spring in place) into the housing. Position it where the Handle hole aligns with the two Housing holes. Then push retaining pin in.

24. Repeat steps 1 thru 23 for opposite Bowl

PART THREE Sanitizing Dispenser

25. Prepare (4) Gallons of Sanitizer solution using warm water and a Sanitizing agent approved for Food Handling Equipment. Mix this according to instructions for the Sanitizer or to a ratio of 200ppm. *Caution: Read Sanitizer label instructions and follow all safety recommendations.*

26. Pour (2) Gallons of sanitizing solution into each Bowl. Use a long handled soft bristle brush to wash all inside Bowl surfaces with the solution.

27. Use a Sponge or Soft Cloth dipped in warm soapy water to clean the top and bottom of the Bowl Lids. **DO NOT IMMERSE THE LIDS IN WATER.** As a final step, dip the sponge in the Sanitizer solution and thoroughly clean the bottom of the Lids.

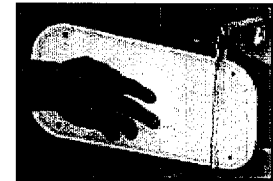

28. Install both Lids on to the Bowls. Turn both Dispenser Switches "ON" and allow machine to run for 30 seconds. Turn Switches "OFF" and drain all sanitizer solution from Bowls.

Fill Dispenser with Fresh Product and turn Switches "ON" and allow to freeze (1 to 1 ½ Hrs.). Approximately (3) Gallons of Product per Bowl is required.

OPERATING TIPS

1. Keep bowls as full as possible during all open hours. Add fresh product frequently. Never let level drop below the "Minimum" line and never fill over the "Maximum" line.
2. Keep the Dispenser clean and Sanitized on a regular schedule.
3. Make sure Dispenser has at least 3" clearance on all sides for air flow.
4. Dispenser should be set to automatically go on "cold drink" mode during closing hours. Your ICEE Representative will adjust the settings for your hours.

Problems or Questions? Call The Carpigiani Company 800-648-4389 7 days including holidays.

CLEANING THE FAUCET

For machines with a handle locking system, remove the tap padlock and then take the locking tap rod away (#8 – arrow I), remove the fastener (#7 – arrow J), disconnect the dispensing handle (#1 – arrow K). By pushing upward (arrow L), take the spring (#3) out from its holder (#2 – arrow M), then push the piston downward (#6 – arrow N), remove the o-ring (#5 – arrow P) and the special gasket (#4 – arrow Q).

Proceed to clean everything with water and neutral soap, rinse and reassemble without damaging the gaskets as follows: put in place the special gasket (#4 – arrow A), put the o-ring (#5) back in its piston slot (#6 – arrow C), insert the spring (#3 – arrow D), put the cap in place (#2 – arrow E), put the handle in place (#1 – arrow F), insert the fastener (#7 – arrow G), and if you want to lock the tap, insert the locking tap rod (#8 – arrow H) and lock.

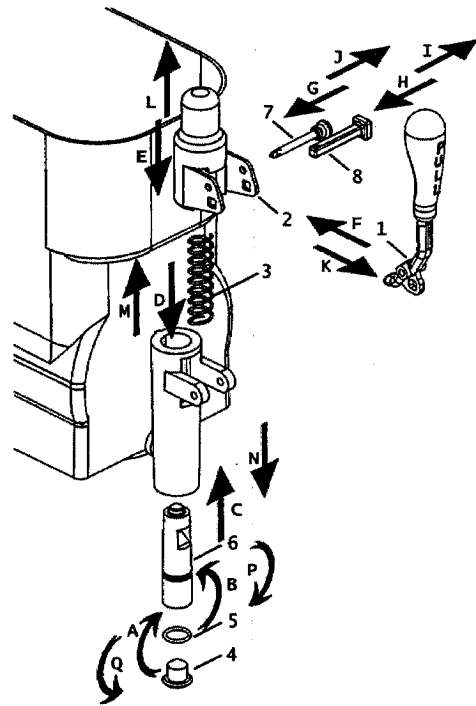

Figure 9

HOW TO OPERATE

1. Once the bowl has been cleaned and sanitized, fill the mix tank with the desired liquid product (3 gallons maximum). Do not overfill the tank. **NOTE THAT WHEN READY, SLUSH OCCUPIES MORE VOLUME THAN THE LIQUID (approximately 3.5 gallons of slush for 3 gallons of liquid).**
2. If using natural products as a base (coffee, lemon juice, orange juice, etc.), it is required that 5 to 7 oz. of sugar per gallon be added. If using a concentrate, follow the mixing instructions from the supplier. In general the brix ratio (sugar content) of the product solution (liquid mix) should not be less than 11.
3. To access to switches and timer, open the switch panel cover by pushing on the side (arrow A) and pulling (arrow A') (Fig. 10).

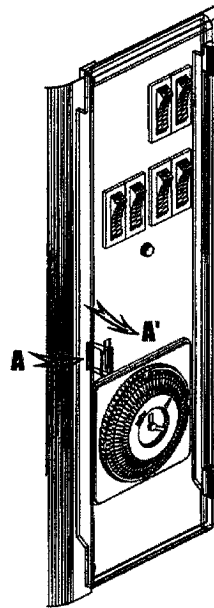

Figure 10

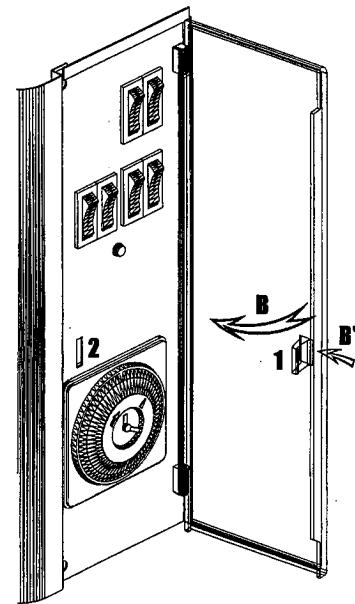

Figure 11

To close the cover (arrow B'), push on the front (arrow B) until the clear plastic part (1) snaps closed (Fig. 11).

4. To operate, press main power switch and agitator switch to ON position (Figure 12). **NOTE: The agitator switch must be to ON position before setting to liquid or slush mode.**
 - 4.1 For slush, press the cooler switch to bottom position (II / *).
 - 4.2 For liquid, press the cooler switch to up position (I / ▲). If the machine is being used as a liquid cooler, it is provided with an inside thermostat for controlling the liquid temperature.

Note that your machine is equipped with a time delay relay that provides for a four minute delay from the time of the initial start. This is to prevent the compressor from short cycling. Once the compressor is ON, the green light will be on.

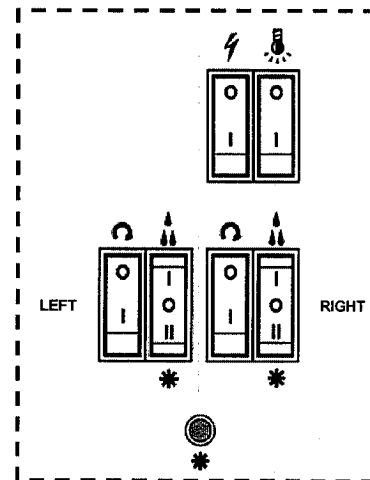

Figure 12

Note: The cooler switch is a three position switch and in order to have the compressor off, all the cooler switches need to be in the middle position.

5. To illuminate the mix tank cover display on top of the unit and the product in the bowl press the display light switch to down position (I / ●).

CAUTION: IF THE MACHINE IS STOPPED AT NIGHT WITH ICE IN THE TANK, REMOVE ALL ICE SLABS BEFORE STARTING.

LIQUID DENSITY ADJUSTEMENT

To adjust the density/consistency of the slush there is an adjustment knob (Figure 13, #2) at the rear, right corner of the dispenser (#1).

Turn the knob right (clockwise) or left (counter clockwise) (arrow C and B) The consistency indicator (#4) will go up or down (arrow D and E)

To firm up the product, turn the set knob counter clockwise, which will move the indicator down to a higher number position

To soften / warm up the product, turn the set knob clockwise, which will move the indicator up to a lower number position

NOTE: when using a new product, or on initial start up, it is recommended that you set the consistency indicator to the lowest/warmest setting and increase as desired. Please note that the machines are pre-set at the factory at a medium setting (number 2.5)

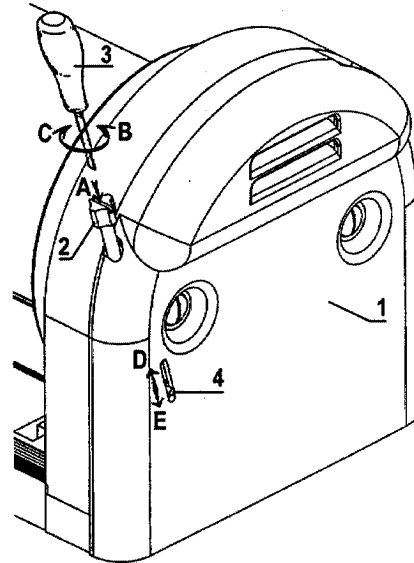

Figure 13

TANK WITH PADLOCK

Fitting the lid over the tank (Figure 14):

- 1° Slide the rim into the slot situated at the back of the tank. Lift slightly the front of the lid.
- 2° Lower the lid and fit onto the tank.
- 3° Insert the padlock into holes of the front rims of the tank and the lid. Close it.

Note:

- A. The lid can be turned back to front (reversible). Proceed as above.
- B. In order to take off the lid, the padlock must be opened and released; then follow the instructions in reverse order

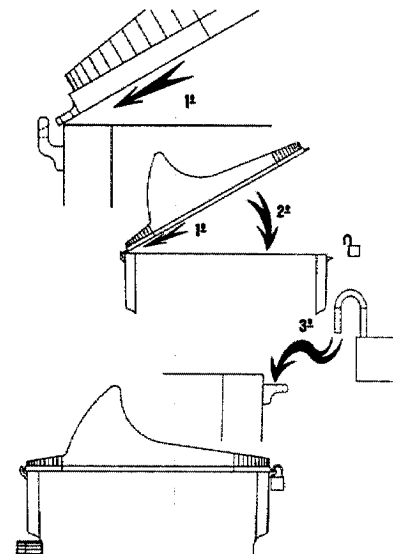

Figure 14